

INDEX

Sprockets - Platewheels	pag.	2
"Asa" sprockets - platewheels	pag.	20
Duplex platewheels for two simple chains	pag.	26
Stainless steel sprockets - Aisi 304 L - Simplex sprockets hardened teeth	pag.	28
Simplex sprockets hardened teeth + bore + keyway + setscrew holes	pag.	29
Taper-Lock® sprockets	pag.	32
Cast iron sprockets	pag.	34
Platewheels for conveyor chain	pag.	36
Table top wheels	pag.	38
Chain stretcher sprockets	pag.	38
Welding hubs (to platewheels)	pag.	38
<hr/>		
Roller chains TPM® - QRC®	pag.	40
Roller chains RCX®	pag.	43
Conveyor chains CRT®	pag.	45
Chain guide rails in polyethylene	pag.	48
<hr/>		
Spurgears	pag.	52
Racks	pag.	57
<hr/>		
Bevel gears - standard execution	pag.	58
Bevel gears - special execution	pag.	61
Bevel gears - execution DIN 3971	pag.	71
Spiral bevel gears "Gleason"	pag.	74
<hr/>		
Adjustable Taper-Lock® pulleys for V-belts	pag.	78
Poly-V belts	pag.	80
Poly-V belts pulleys for Taper bushes	pag.	81
Timing belts "GATES®"	pag.	86
Timing belt pulleys	pag.	90
Timing belt pulleys "Export" Type	pag.	104
Taper-Lock® timing belt pulleys	pag.	109
Timing bars	pag.	115
<hr/>		
HTD® belts "GATES®"	pag.	116
HTD® timing belt pulleys - pilot bore	pag.	120
Taper-Lock® HTD® pulleys	pag.	128
PowerGrip HTD® bars	pag.	134
<hr/>		
PowerGrip GT® belts - "GATES®"	pag.	136
PowerGrip GT® pulleys	pag.	138
PowerGrip GT® bars	pag.	141
<hr/>		
Poly Chain GT2 belts "GATES®"	pag.	142
Pulleys Poly Chain GT Taper-Lock®	pag.	144
Poly Chain GT bars	pag.	153
<hr/>		
Metric belts "T" "MECTROL"	pag.	154
Metric pulleys "T"	pag.	157
Metric bars "T"	pag.	161
Metric belts "AT" "MECTROL"	pag.	162
Metric pulleys "CT" for "AT" belts	pag.	164
Metric bars "CT" for metric belts "AT"	pag.	168
V-Belts Poliflex® "GATES®"	pag.	169
<hr/>		
Clamping belt plates	pag.	170
Flanges for pulleys	pag.	171
Adaptors for taper bushes	pag.	173
Taper bushes RCB®	pag.	174
Weld-on hubs for Taper-Lock® bush	pag.	175
Demountable hubs for Taper-Lock® bush	pag.	175
Locking assemblies	pag.	176
Elastomeric plain bore couplings "Giflex®" GE-T - GE-T SG	pag.	197
Flexible couplings "Giflex®" GF- with synthetic resin sleeve	pag.	210
Flexible couplings "Giflex®" GFA - GFAS - with steel sleeve	pag.	214
<hr/>		
Torque limiters	pag.	224
Washers "C-RGS" - and collars "C-ABU" - "C-AB" - "C-ADB"	pag.	226
Washers "C-RC" - "C-RS"	pag.	229
<hr/>		
General Terms and Conditions of Sale		



SPROCKETS AND PLATEWHEELS DESIGNED FOR ROLLER CHAINS

The range of sprockets and wheels designed for chains manufactured by our Company provides an all-round solution to the needs of industry in the sector of flexible mechanical transmissions and is the result of a manufacturing process that is designed to achieve the top in terms of technical and quality performance.

Our production programme includes sprockets and wheels designed for chains, produced in compliance with the principles and with the most recent Standards and International Unified Standards: UNI, ISO, DIN, ANSI, etc.

However, the standards define a profile with minimum dimensions and a profile with maximum dimensions for the wheel space for chains and rollers and the actual profile must lie within these values. There is the option of selecting proportioning criteria for the profile, since the tolerances that the Standards leave to the manufacturer's discretion are quite wide. The profiles can be optimised in terms of smooth transmission and the tooth's capacity to support greater stresses. This has led to the systematic development of a series of standardised profiles for which the geometry can be reproduced with great precision by tools designed specifically by computer and the reference profile of which is protected by the Company's know-how. A valued feature of this optimised profile, which is a characteristic exclusive to **CHIARAVALLI Trasmissioni spa**, is that of enhancing the "polygonal" chain wrap-around on the sprocket and on the platewheel, reproducing the motion discontinuity which is achieved even in the case of unfavourable transmission ratios and centre distances. As a result of this **CHIARAVALLI Trasmissioni spa** has been able to include sprockets with a very low number of teeth in its catalogue and production programme.

Respecting precision with limited machining errors is beneficial, even if the toothed wheel-chain set represents a somewhat "basic" transmission solution. This precision is assured by the systematic use of CNC machines and technologies developed to minimise the shearing stress and to improve the degree of surface finish. The sprockets and wheels designed for chains included in the catalogue are also manufactured in the version with the "Taper-lock" taper bush piece system particularly favoured in applications that require easy assembly and very precise centring tolerances.

Our sales programme is completed with single and multiple roller chains, and special chains suitable for every industrial application and **CHIARAVALLI Trasmissioni spa** is also able to manufacture sprockets and platewheels suitable for chains in a specific execution, produced to drawing any of material and with induction hardening and case-hardening and hardening applied to steel wheels and sprockets.

S P R O C K E T S

Z	d _e	d _p	SINGLE		
			d _m	D1	A
8	15.2	13.06	7	4	10
9	16.8	14.62	8	5	10
10	18.3	16.18	9	5	10
11	19.9	17.75	11	6	10
12	21.5	19.32	12	6	10
13	23.0	20.89	14	6	10
14	24.6	22.47	15	6	10
15	26.2	24.04	16	6	10
16	27.8	25.63	18	8	13
17	29.4	27.20	18	8	13
18	30.9	28.79	18	8	13
19	32.5	30.38	18	8	13
20	34.1	31.96	18	8	13
21	35.7	33.54	20	8	13
22	37.3	35.13	20	8	13
23	38.9	36.72	20	8	13
24	40.5	38.30	20	8	13
25	42.0	39.89	20	8	13
26	43.6	41.48	25	8	15
27	45.2	43.07	25	8	15
28	46.8	44.65	25	8	15
29	48.4	46.25	25	8	15
30	50.0	47.83	25	8	15
31	51.6	49.42	30	8	15
32	53.2	51.01	30	8	15
33	54.8	52.60	30	8	15
34	56.3	54.19	30	8	15
35	57.9	55.78	30	8	15
36	59.5	57.37	30	8	15
37	61.1	58.96	30	8	15
38	62.7	60.54	30	8	15
39	64.3	62.13	30	8	15
40	65.9	63.73	30	8	15

5 x 2.5 mm

for roller chains in compliance with DIN 8187 ISO/R 606

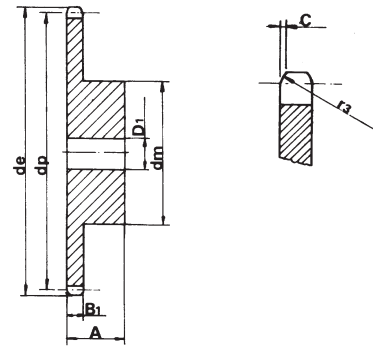

SPROCKET

	mm
TOOTH RADIUS r ₃	5
RADIUS WIDTH C	0.6
SPROCKET TOOTH WIDTH B ₁	2.3

CHAIN

	mm
PITCH	5
INNER WIDTH	2.5
ROLLER - Ø	3.2

MATERIAL: C 45 UNI 7845

P L A T E W H E E L S

Z	d _e	d _p	S		Z	d _e	d _p	S	
			D ₁					D ₁	
8	15.2	13.06	4		44	72.2	70.09	8	
9	16.8	14.62	4		45	73.8	71.68	8	
10	18.3	16.18	4		46	75.4	73.27	8	
11	19.9	17.75	5		47	77.0	74.86	8	
12	21.5	19.32	5		48	78.6	76.45	8	
13	23.0	20.89	5		49	80.2	78.03	8	
14	24.6	22.47	5		50	81.8	79.63	8	
15	26.2	24.04	5		51	83.4	81.22	10	
16	27.8	25.63	6		52	85.0	82.81	10	
17	29.4	27.20	6		53	86.6	84.40	10	
18	30.9	28.79	6		54	88.1	85.97	10	
19	32.5	30.38	6		55	89.7	87.58	10	
20	34.1	31.96	6		56	91.3	89.17	10	
21	35.7	33.54	8		57	92.9	90.76	10	
22	37.3	35.13	8		58	94.5	92.35	10	
23	38.9	36.72	8		59	96.1	93.94	10	
24	40.5	38.30	8		60	97.7	95.53	10	
25	42.0	39.89	8		62	100.9	98.72	12	
26	43.6	41.48	8		64	104.1	101.90	12	
27	45.2	43.07	8		65	105.6	103.49	12	
28	46.8	44.65	8		66	107.2	105.08	12	
29	48.4	46.25	8		68	110.4	108.26	12	
30	50.0	47.83	8		70	113.6	111.44	12	
31	51.6	49.42	8		72	116.8	114.63	12	
32	53.2	51.01	8		75	121.6	119.40	12	
33	54.8	52.60	8		76	123.1	120.99	12	
34	56.3	54.19	8		78	126.3	124.17	12	
35	57.9	55.78	8		80	129.5	127.35	12	
36	59.5	57.37	8		85	137.5	135.31	14	
37	61.1	58.96	8		90	145.4	143.27	14	
38	62.7	60.54	8		95	153.4	151.22	14	
39	64.3	62.13	8		100	161.3	159.18	14	
40	65.9	63.73	8		110	177.2	175.09	14	
41	67.5	65.31	8		114	183.6	181.46	14	
42	69.1	66.91	8		120	193.2	191.01	14	
43	70.6	68.49	8		125	201.1	198.96	14	

5 x 2.5 mm

for roller chains in compliance with DIN 8187 ISO/R 606

The plate size is increased by h = 4mm starting from Z.51

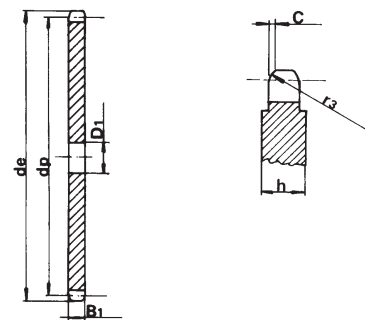

PLATEWHEEL

	mm
TOOTH RADIUS r ₃	5
RADIUS WIDTH C	0.6
PLATE TOOTH WIDTH B ₁	2.3

CHAIN

	mm
PITCH	5
INNER WIDTH	2.5
ROLLER - Ø	3.2

S P R O C K E T S

Z	d _e	d _p	SINGLE		
			d _m	D ₁	A
8	18.0	15.67	9.8	5	10
9	19.9	17.54	11.5	5	10
10	21.7	19.42	13	6	10
11	23.6	21.30	14	6	10
12	25.4	23.18	16	6	10
13	27.3	25.05	18	8	10
14	29.2	26.96	20	8	10
15	31.0	28.86	20	8	10
16	33.0	30.76	20	8	13
17	35.0	32.65	20	8	13
18	36.9	34.55	20	8	13
19	38.8	36.44	20	8	13
20	40.7	38.34	20	8	13
21	42.6	40.25	25	8	13
22	44.5	42.16	25	8	13
23	46.4	44.06	25	8	13
24	48.3	45.96	25	8	13
25	50.2	47.87	25	8	13
26	52.1	49.76	30	8	15
27	54.0	51.67	30	8	15
28	55.9	53.58	30	8	15
29	57.8	55.50	30	8	15
30	59.8	57.42	30	8	15
31	61.7	59.31	30	8	15
32	63.6	61.21	30	8	15
33	65.5	63.11	30	8	15
34	67.4	65.02	30	8	15
35	69.3	66.93	30	8	15
36	71.2	68.84	30	8	15
37	73.1	70.75	30	8	15
38	75.0	72.66	30	8	15
39	76.9	74.57	30	8	15
40	78.9	76.47	30	8	15
45	88.5	86.01	40	10	16
50	98.0	95.55	50	12	20
57	111.4	108.93	50	12	20
76	147.6	145.19	60	12	20

6 x 2.8 mm

for roller chains in compliance with DIN 8187 ISO/R 606

the plate is increased by h = 4mm for Z.57 and Z.76

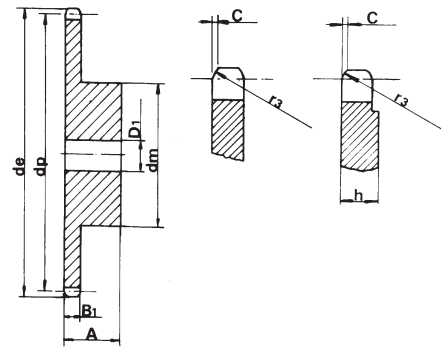

SPROCKET

	mm
TOOTH RADIUS r ₃	6
RADIUS WIDTH C	0.7
SPROCKET TOOTH WIDTH B ₁	2.6

CHAIN

	mm
PITCH	6
INNER WIDTH	2.8
ROLLER - Ø	4

MATERIAL: C 45 UNI 7845

P L A T E W H E E L S

Z	d _e	d _p	S		S		
			D ₁		D ₁		
8	18.0	15.67	5	44	86.6	84.10	10
9	19.9	17.54	5	45	88.5	86.01	10
10	21.7	19.42	6	46	90.4	87.92	10
11	23.6	21.30	6	47	92.3	89.93	10
12	25.4	23.18	6	48	94.2	91.74	10
13	27.3	25.05	8	49	96.1	93.64	10
14	29.2	26.96	8	50	98.0	95.55	10
15	31.0	28.86	8	51	99.9	97.46	12
16	33.0	30.76	8	52	101.8	99.37	12
17	35.0	32.65	8	53	103.7	101.27	12
18	36.9	34.55	8	54	105.6	103.17	12
19	38.8	36.44	8	55	107.6	105.08	12
20	40.7	38.34	8	56	109.5	107.00	12
21	42.6	40.25	8	57	111.4	108.93	12
22	44.5	42.16	8	58	113.3	110.82	12
23	46.4	44.06	8	59	115.2	112.71	12
24	48.3	45.96	8	60	117.1	114.62	12
25	50.2	47.87	8	62	120.9	118.45	14
26	52.1	49.76	8	64	124.7	122.27	14
27	54.0	51.67	8	65	126.6	124.18	14
28	55.9	53.58	8	66	128.5	126.09	14
29	57.8	55.50	8	68	132.4	129.91	14
30	59.8	57.42	8	70	136.2	133.73	14
31	61.7	59.31	8	72	140.0	137.55	16
32	63.6	61.21	8	75	145.7	143.28	16
33	65.5	63.11	8	76	147.6	145.19	16
34	67.4	65.02	8	78	151.5	149.01	16
35	69.3	66.93	8	80	155.3	152.82	16
36	71.2	68.84	8	85	164.8	162.37	16
37	73.1	70.75	8	90	174.4	171.92	16
38	75.0	72.66	8	95	183.9	181.47	16
39	76.9	74.57	8	100	193.5	191.01	16
40	78.9	76.47	8	110	212.6	210.11	16
41	80.8	78.38	10	114	220.2	217.75	16
42	82.7	80.28	10	120	231.7	229.20	16
43	84.7	82.19	10	125	241.2	238.75	16

6 x 2.8 mm

for roller chains in compliance with DIN 8187 ISO/R 606

The plate size is increased by h = 4mm starting from Z.51

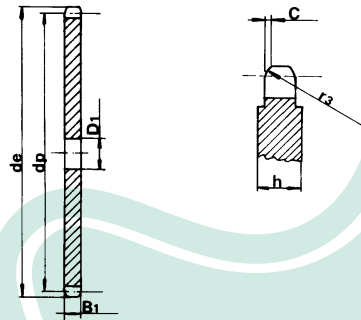

PLATEWHEEL

	mm
TOOTH RADIUS r ₃	6
RADIUS WIDTH C	0.7
PLATE TOOTH WIDTH B ₁	2.6

CHAIN

	mm
PITCH	6
INNER WIDTH	2.8
ROLLER - Ø	4

S P R O C K E T S

Z	d _e	d _p	SINGLE		
			d _m	D1	A
8	19.4	16.58	10	6	12
9	21.4	18.56	11.5	6	12
10	23.3	20.55	13	6	12
11	25.3	22.54	15	8	13
12	27.3	24.53	17	8	13
13	29.3	26.53	17	8	13
14	31.3	28.53	17	8	13
15	33.3	30.53	20	8	13
16	35.3	32.55	22	8	14
17	37.3	34.55	22	8	14
18	39.4	36.56	25	8	14
19	41.4	38.58	25	8	14
20	43.4	40.58	25	8	14
21	45.4	42.60	30	8	14
22	47.4	44.62	30	8	14
23	49.4	46.63	30	8	14
24	51.4	48.64	30	8	14
25	53.5	50.66	30	8	14
26	55.5	52.67	30	8	16
27	57.5	54.69	30	8	16
28	59.5	56.71	30	8	16
29	61.5	58.73	30	8	16
30	63.6	60.75	30	8	16
31	65.6	62.76	30	8	16
32	67.6	64.78	30	8	16
33	69.6	66.80	30	8	16
34	71.6	68.82	30	8	16
35	73.6	70.84	30	8	16
36	75.6	72.85	30	8	16
37	77.7	74.87	30	8	16
38	79.7	76.89	30	8	16
39	81.7	78.91	30	8	16
40	83.7	80.93	30	8	16

1/4" x 1/8"

for roller chains in compliance with DIN 8188 ASA 25 ISO/R 606 - ANSI B 29.1

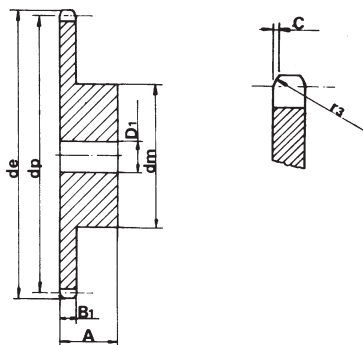

SPROCKET mm

TOOTH RADIUS r ₃	6.4
RADIUS WIDTH C	0.7
SPROCKET TOOTH WIDTH B ₁	2.9

CHAIN mm

PITCH	6.35
INNER WIDTH	3.18
ROLLER - Ø	3.3

MATERIAL: C 45 UNI 7845

P L A T E W H E E L S

Z	d _e	d _p	S			Z	d _e	d _p	D ₁
			D ₁						
8	19.4	16.58	6			44	91.8	89.01	10
9	21.4	18.56	6			45	93.8	91.03	10
10	23.3	20.55	6			46	95.8	93.05	10
11	25.3	22.54	8			47	97.9	95.07	10
12	27.3	24.53	8			48	99.9	97.09	10
13	29.3	26.53	8			49	101.9	99.10	10
14	31.3	28.53	8			50	103.9	101.13	10
15	33.3	30.53	8			51	105.9	103.14	12
16	35.3	32.55	8			52	108.0	105.16	12
17	37.3	34.55	8			53	110.0	107.18	12
18	39.4	36.56	8			54	112.0	109.18	12
19	41.4	38.58	8			55	114.0	111.23	12
20	43.4	40.58	8			56	116.0	113.25	12
21	45.4	42.60	8			57	118.1	115.27	12
22	47.4	44.62	8			58	120.1	117.29	12
23	49.4	46.63	8			59	122.1	119.31	12
24	51.4	48.64	8			60	124.1	121.32	12
25	53.5	50.66	8			62	128.2	125.37	12
26	55.5	52.67	8			64	132.2	129.41	12
27	57.5	54.69	8			65	134.2	131.43	12
28	59.5	56.71	8			66	136.2	133.45	14
29	61.5	58.73	8			68	140.3	137.49	14
30	63.6	60.75	8			70	144.3	141.53	14
31	65.6	62.76	10			72	148.4	145.58	14
32	67.6	64.78	10			75	154.4	151.63	14
33	69.6	66.80	10			76	156.5	153.66	14
34	71.6	68.82	10			78	160.5	157.70	16
35	73.6	70.84	10			80	164.5	161.74	16
36	75.6	72.85	10			85	174.6	171.85	16
37	77.7	74.87	10			90	184.7	181.95	16
38	79.7	76.89	10			95	194.8	192.05	16
39	81.7	78.91	10			100	204.9	202.15	16
40	83.7	80.93	10			110	225.1	222.37	16
41	85.7	82.95	10			114	233.2	230.45	16
42	87.8	84.97	10			120	245.4	242.58	16
43	89.8	86.98	10			125	255.5	252.68	16

1/4" x 1/8"

for roller chains in compliance with DIN 8188 ASA 25 ISO/R 606 - ANSI B 29.1

The plate size is increased by h = 4mm starting from Z.51

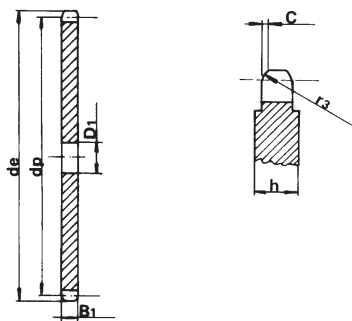

PLATEWHEEL mm

TOOTH RADIUS r ₃	6.4
RADIUS WIDTH C	0.7
PLATE TOOTH WIDTH B ₁	2.9

CHAIN mm

PITCH	6.35
INNER WIDTH	3.18
ROLLER - Ø	3.3

S P R O C K E T S

8 x 3 mm

for roller chains in compliance with DIN 8187 ISO/R 606

The plate size is increased by $h = 4\text{mm}$ for Z.57 and Z.76

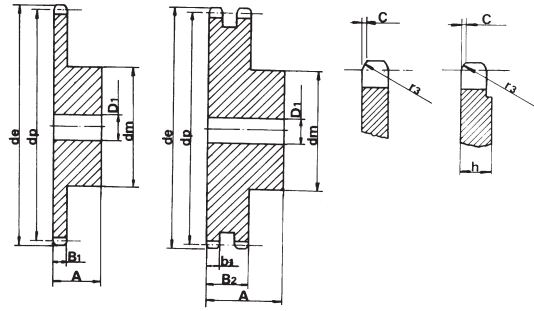

SPROCKET

	mm
TOOTH RADIUS r_3	8
RADIUS WIDTH C	1.0
SPROCKET TOOTH WIDTH B_1	2.8
SPROCKET TOOTH WIDTH b_1	2.7
SPROCKET TOOTH WIDTH B_2	8.3

CHAIN

	mm
PITCH	8
INNER WIDTH	3
ROLLER - \varnothing	5

MATERIAL: C 45 UNI 7845

Z	d_e	d_p	SINGLE			DOUBLE		
			d_m	D_1	A	d_m	D_1	A
8	24.0	20.90	13	6	12	12	8	18
9	26.6	23.39	15	6	12	15	8	18
10	29.2	25.89	17	8	12	17	8	18
11	31.7	28.39	18	8	13	19	10	18
12	34.2	30.91	20	8	13	21	10	18
13	36.7	33.42	23	8	13	24	10	18
14	39.2	35.95	25	8	13	26	10	18
15	41.7	38.48	28	8	13	29	10	18
16	44.3	41.01	30	8	14	32	10	20
17	46.8	43.53	30	8	14	34	10	20
18	49.3	46.07	30	8	14	37	10	20
19	51.9	48.61	30	8	14	39	10	20
20	54.4	51.14	30	8	14	40	10	20
21	57.0	53.68	35	8	14	40	10	20
22	59.5	56.21	35	8	14	40	10	20
23	62.0	58.75	35	8	14	40	10	20
24	64.6	61.29	35	8	14	40	10	20
25	67.5	63.83	35	8	14	40	10	20
28	69.5	66.37	40	10	16	50	12	22
27	72.2	68.91	40	10	16	50	12	22
28	74.8	71.45	40	10	16	50	12	22
29	77.3	73.99	40	10	16	50	12	22
30	79.8	76.53	40	10	16	50	12	22
31	82.4	79.08	40	10	16	60	12	22
32	84.9	81.61	40	10	16	60	12	22
33	87.5	84.16	40	10	16	60	12	22
34	90.0	86.70	40	10	16	60	12	22
35	92.5	89.25	40	10	16	60	12	22
36	95.0	91.79	40	10	16	60	12	22
37	97.6	94.33	40	10	16	60	12	22
38	100.2	96.88	40	10	16	60	12	22
39	102.7	99.42	40	10	16	60	12	22
40	105.3	101.97	40	10	16	60	12	22
45	118.0	114.69	60	12	20			
50	130.7	127.41	60	12	20			
57	148.6	145.22	80	14	20			
76	197.7	193.59	80	20	25			

P L A T E W H E E L S

8 x 3 mm

for roller chains in compliance with DIN 8187 ISO/R 606

The plate size is increased by $h = 4\text{mm}$ starting from Z.46

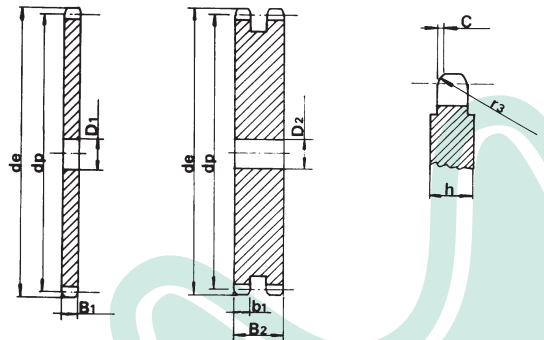

PLATEWHEEL

	mm
TOOTH RADIUS r_3	8
RADIUS WIDTH C	1.0
PLATE TOOTH WIDTH B_1	2.8
PLATE TOOTH WIDTH b_1	2.7
PLATE TOOTH WIDTH B_2	8.3

CHAIN

	mm
PITCH	8
INNER WIDTH	3
ROLLER - \varnothing	5

Z	d_e	d_p	S		D		Z	d_e	d_p	S		D	
			D_1	D_2	D_1	D_2				D_1	D_2		
8	24.0	20.90	6	6	44	115.5	112.14	12	14				
9	26.6	23.39	6	6	45	118.0	114.69	12	14				
10	29.2	25.89	6	8	46	120.6	117.23	12	14				
11	31.7	28.39	8	8	47	123.1	119.77	12	14				
12	34.2	30.91	8	8	48	125.6	122.32	12	14				
13	36.7	33.42	8	8	49	128.2	124.86	12	14				
14	39.2	35.95	8	8	50	130.7	127.41	12	14				
15	41.7	38.48	8	8	51	133.3	129.95	14	16				
16	44.3	41.01	8	10	52	135.8	132.49	14	16				
17	46.8	43.53	8	10	53	138.4	135.04	14	16				
18	49.3	46.07	8	10	54	140.9	137.59	14	16				
19	51.9	48.61	8	10	55	143.5	140.13	14	16				
20	54.4	51.14	8	10	56	146.0	142.68	14	16				
21	57.0	53.68	8	10	57	148.6	145.22	14	16				
22	59.5	56.21	8	10	58	151.0	147.77	14	16				
23	62.0	58.75	8	10	59	153.6	150.31	14	16				
24	64.6	61.29	8	10	60	156.2	152.85	14	16				
25	67.5	63.83	8	10	62	162.0	157.95	16	20				
26	69.5	66.37	10	12	64	167.1	163.04	16	20				
27	72.2	68.91	10	12	65	169.6	165.58	16	20				
28	74.8	71.45	10	12	66	172.2	168.13	16	20				
29	77.3	73.99	10	12	68	177.3	173.22	16	20				
30	79.8	76.53	10	12	70	182.4	178.31	16	20				
31	82.4	79.08	10	12	72	187.5	183.41	20	20				
32	84.9	81.61	10	12	75	195.1	191.04	20	20				
33	87.5	84.16	10	12	76	197.7	193.59	20	20				
34	90.0	86.70	10	12	78	202.8	198.68	20	20				
35	92.5	89.25	10	12	80	207.9	203.77	20	20				
36	95.0	91.79	10	12	85	220.6	216.50	20	20				
37	97.6	94.33	10	12	90	233.4	229.23	20	20				
38	100.2	96.88	10	12	95	246.1	241.96	20	20				
39	102.7	99.42	10	12	100	258.9	254.68	20	20				
40	105.3	101.97	10	12	110	284.3	280.15	20	20				
41	107.8	104.51	12	14	114	294.5	290.33	20	20				
42	110.4	107.05	12	14	120	310.0	305.61	20	20				
43	112.9	109.60	12	14	125	322.5	318.34	20	20				

S P R O C K E T S

3/8" x 7/32"

for roller chains in compliance with
DIN 8187 ISO/R 606

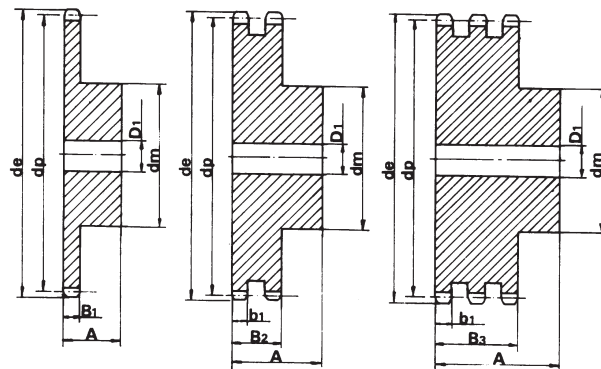
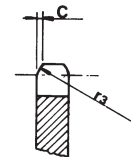

SPROCKET

mm

TOOTH RADIUS r_3	10
RADIUS WIDTH C	1
SPROCKET TOOTH WIDTH B_1	5.3
SPROCKET TOOTH WIDTH b_1	5.2
SPROCKET TOOTH WIDTH B_2	15.4
SPROCKET TOOTH WIDTH B_3	25.6

CHAIN

mm

PITCH	9.525
INNER WIDTH	5.72
ROLLER - \emptyset	6.35

MATERIAL: C 45 UNI 7845

Z	d_e	d_p	SINGLE			DOUBLE			TRIPLE		
			d_m	D_1	A	d_m	D_1	A	d_m	D_1	A
8	28.0	24.89	15	6	22	15	6	22	15	6	32
9	31.0	27.85	18	8	22	18	8	22	18	8	32
10	34.0	30.82	20	8	22	20	8	22	20	10	32
11	37.0	33.80	22	8	25	22	10	25	22	10	35
12	40.0	36.80	25	8	25	25	10	25	25	10	35
13	43.0	39.79	28	10	25	28	10	25	28	10	35
14	46.3	42.80	31	10	25	31	10	25	31	12	35
15	49.3	45.81	34	10	25	34	10	25	34	12	35
16	52.3	48.82	37	10	28	37	12	30	37	12	35
17	55.3	51.83	40	10	28	40	12	30	40	12	35
18	58.3	54.85	43	10	28	43	12	30	43	12	35
19	61.3	57.87	45	10	28	46	12	30	46	12	35
20	64.3	60.89	46	10	28	49	12	30	49	12	35
21	68.0	63.91	48	12	28	52	12	30	52	14	40
22	71.0	66.93	50	12	28	55	12	30	55	14	40
23	73.5	69.95	52	12	28	58	12	30	58	14	40
24	77.0	72.97	54	12	28	61	12	30	61	14	40
25	80.0	76.00	57	12	28	64	12	30	64	14	40
26	83.0	79.02	60	12	28	67	12	30	67	14	40
27	86.0	82.05	60	12	28	70	12	30	70	14	40
28	89.0	85.07	60	12	28	73	12	30	73	14	40
29	92.0	88.09	60	12	28	76	12	30	76	14	40
30	94.7	91.12	60	12	30	79	12	30	79	14	40
31	98.3	94.15	65	14	30	80	16	30	80	16	40
32	101.3	97.17	65	14	30	80	16	30	80	16	40
33	104.3	100.20	65	14	30	80	16	30	80	16	40
34	107.3	103.23	65	14	30	80	16	30	85	16	40
35	110.4	106.26	65	14	30	80	16	30	85	16	40
36	113.4	109.29	70	16	30	90	16	30	90	16	40
37	116.4	112.32	70	16	30	90	16	30	90	16	40
38	119.5	115.35	70	16	30	90	16	30	90	16	40
39	122.5	118.37	70	16	30	90	16	30	90	16	40
40	125.5	121.40	70	16	30	90	16	30	90	16	40

P L A T E W H E E L S

3/8" x 7/32"

for roller chains in compliance with
DIN 8187 ISO/R 606

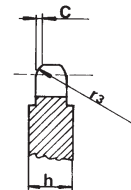

The single plate size is increased by $h = 7$ mm starting
from Z.100

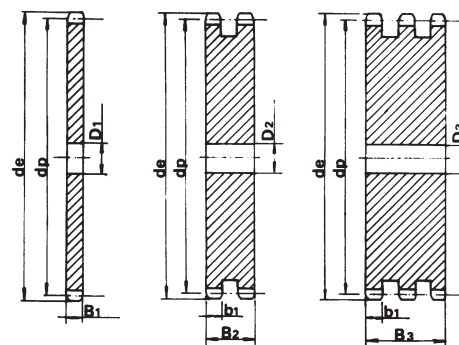

PLATEWHEEL

mm

TOOTH RADIUS r_3	10
RADIUS WIDTH C	1
PLATE TOOTH WIDTH B_1	5.3
PLATE TOOTH WIDTH b_1	5.2
PLATE TOOTH WIDTH B_2	15.4
PLATE TOOTH WIDTH B_3	25.6

CHAIN

mm

PITCH	9.525
INNER WIDTH	5.72
ROLLER - \emptyset	6.35

Z	d_e	d_p	S D T			Z	d_e	d_p	S D T		
			D_1	D_2	D_3				D_1	D_2	D_3
8	28.0	24.89	6	6	6	44	137.6	133.52	16	16	16
9	31.0	27.85	7	8	8	45	140.7	136.55	16	16	16
10	34.0	30.82	7	8	10	46	143.7	139.58	16	16	16
11	37.0	33.80	8	10	10	47	146.7	142.61	16	16	16
12	40.0	36.80	8	10	10	48	149.7	145.64	16	16	16
13	43.0	39.79	8	10	10	49	152.7	148.66	16	16	16
14	46.3	42.80	8	10	12	50	155.7	151.69	16	16	16
15	49.3	45.81	8	10	12	51	158.7	154.72	16	16	20
16	52.3	48.82	10	12	12	52	161.8	157.75	16	16	20
17	55.3	51.83	10	12	12	53	164.8	160.78	16	16	20
18	58.3	54.85	10	12	12	54	167.8	163.82	16	16	20
19	61.3	57.87	10	12	12	55	170.8	166.85	16	16	20
20	64.3	60.89	10	12	12	56	173.8	169.88	16	16	20
21	68.0	63.91	10	12	14	57	176.9	172.91	16	16	20
22	71.0	66.93	10	12	14	58	179.9	175.93	16	16	20
23	73.5	69.95	10	12	14	59	183.0	178.96	16	16	20
24	77.0	72.97	10	12	14	60	186.0	181.99	16	16	20
25	80.0	76.02	10	12	14	62	192.1	188.06	20	20	20
26	83.0	79.02	10	12	14	64	198.2	194.12	20	20	20
27	86.0	82.02	10	12	14	65	201.6	197.15	20	20	20
28	89.0	85.07	10	12	14	66	204.6	200.18	20	20	25
29	92.0	88.09	10	12	14	68	210.7	206.24	20	20	25
30	94.7	91.12	10	12	14	70	216.7	212.3	20	20	25
31	98.3	94.15	12	14	16	72	222.8	218.37	20	20	25
32	101.3	97.17	12	14	16	75	231.9	227.46	20	20	25
33	104.3	100.20	12	14	16	76	234.9	230.49	20	20	25
34	107.3	103.23	12	14	16	78	241.0	236.55	20	20	25
35	110.4	106.26	12	14	16	80	247.1	242.61	20	20	25
36	113.4	109.29	12	14	16	85	262.2	257.77	20	20	25
37	116.4	112.32	12	14	16	90	277.4	272.93	20	20	25
38	119.5	115.35	12	14	16	95	292.5	288.08	20	20	25
39	122.5	118.37	12	14	16	100	307.7	303.25	20	20	25
40	125.5	121.40	12	14	16	110	338.0	333.55	20	20	25
41	128.5	124.43	16	16	16	114	349.5	345.68	20	20	25
42	131.6	127.46	16	16	16	120	368.3	363.86	20	20	25
43	134.6	130.49	16	16	16	125	383.5	379.02	20	20	25

S P R O C K E T S

1/2" x 1/8"

for roller chains in compliance with DIN 8187 ISO/R 606

The plate size is increased by h = 5 mm starting from Z.31

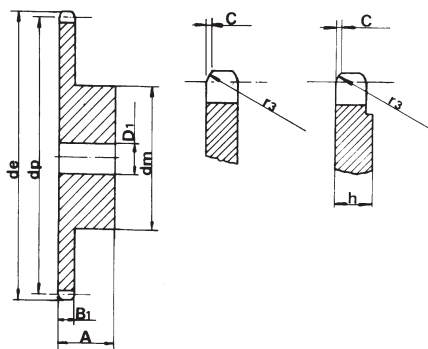

SPROCKET mm

TOOTH RADIUS r_3	13
RADIUS WIDTH C	1.0
SPROCKET TOOTH WIDTH B_1	3

CHAIN mm

PITCH	12.7
INNER WIDTH	3.3
ROLLER - \varnothing	7.75

MATERIAL: C 45 UNI 7845

Z	d_e	d_p	SINGLE		
			d_m	D_1	A
8	37.2	33.18	21	8	14
9	41.5	37.13	25	8	14
10	46.2	41.10	28	8	14
11	49.6	45.07	31	8	16
12	53.9	49.07	35	8	16
13	58.4	53.06	39	8	16
14	62.8	57.07	43	8	16
15	66.8	61.09	47	8	16
16	70.9	65.10	50	10	18
17	74.9	69.11	50	10	18
18	78.9	73.14	50	10	18
19	82.9	77.16	50	10	18
20	86.9	81.19	50	10	18
21	91.0	85.22	60	12	20
22	95.0	89.24	60	12	20
23	99.0	93.27	60	12	20
24	103.0	97.29	60	12	20
25	107.1	101.33	60	12	20
26	111.2	105.36	70	16	20
27	115.4	109.40	70	16	20
28	119.4	113.42	70	16	20
29	123.4	117.46	70	16	20
30	127.5	121.50	70	16	20
31	131.5	125.54	70	16	20
32	135.5	129.56	70	16	20
33	139.6	133.60	70	16	20
34	143.6	137.64	70	16	20
35	147.6	141.68	70	16	20
36	151.7	145.72	70	16	25
37	155.7	149.76	70	16	25
38	159.8	153.80	70	16	25
39	163.8	157.83	70	16	25
40	167.8	161.87	70	16	25

P L A T E W H E E L S

1/2" x 1/8"

for roller chains in compliance with DIN 8187 ISO/R 606

The plate size is increased by h = 4mm starting from Z.30

The plate size is increased by h = 6mm starting from Z.90

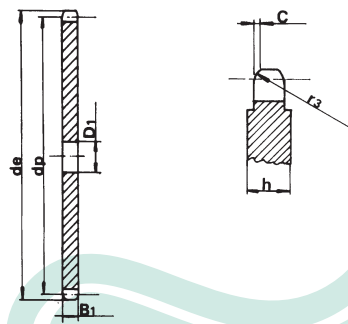

PLATEWHEEL mm

TOOTH RADIUS r_3	13
RADIUS WIDTH C	1.0
PLATE TOOTH WIDTH B_1	3

CHAIN mm

PITCH	12.7
INNER WIDTH	3.3
ROLLER - \varnothing	7.75

Z	d_e	d_p	S		Z	d_e	d_p	D_1
			D_1	S				
8	37.2	33.18	8		43	179.5	173.99	16
9	41.5	37.13	8		44	183.5	178.03	16
10	46.2	41.10	8		45	187.5	182.07	16
11	49.6	45.07	8		46	191.6	186.10	20
12	53.9	49.07	8		47	195.6	190.14	20
13	58.4	53.06	8		48	199.7	194.18	20
14	62.8	57.07	8		49	203.7	198.22	20
15	66.8	61.09	8		50	207.8	202.26	20
16	70.9	65.10	10		51	211.8	206.30	20
17	74.9	69.11	10		52	215.9	210.34	20
18	78.9	73.14	10		53	219.9	214.37	20
19	82.9	77.16	10		54	224.0	218.43	20
20	86.9	81.19	10		55	228.0	222.46	20
21	91.0	85.22	10		56	232.1	226.50	20
22	95.0	89.24	10		57	236.1	230.54	20
23	99.0	93.27	10		58	240.2	234.58	20
24	103.0	97.29	10		59	244.2	238.62	20
25	107.1	101.33	10		60	248.2	242.66	20
26	111.2	105.36	12		62	256.7	250.75	20
27	115.4	109.40	12		64	264.8	258.82	20
28	119.4	113.42	12		65	268.8	262.86	20
29	123.4	117.46	12		66	272.9	266.90	25
30	127.5	121.50	12		68	280.9	274.99	25
31	131.5	125.54	12		70	289.0	283.07	25
32	135.5	129.56	12		72	297.1	291.16	25
33	139.6	133.60	12		76	313.3	307.33	25
34	143.6	137.64	12		78	321.4	315.40	25
35	147.6	141.68	12		80	329.4	323.48	25
36	151.7	145.72	16		85	349.7	343.70	25
37	155.7	149.76	16		90	369.9	363.90	25
38	159.8	153.80	16		95	390.1	384.10	25
39	163.8	157.83	16		100	410.3	404.31	25
40	167.8	161.87	16		110	450.7	444.74	25
41	171.4	165.91	16		114	466.9	460.90	25
42	175.4	169.95	16		120	491.2	485.16	25
					125	511.4	505.37	25

S P R O C K E T S

1/2" x 3/16"

for roller chains in compliance with DIN 8187 ISO/R 606

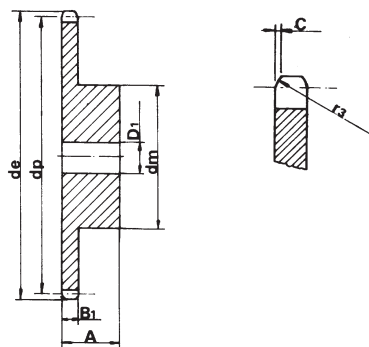

SPROCKET

mm

TOOTH RADIUS r_3	13
RADIUS WIDTH C	1.3
SPROCKET TOOTH WIDTH B_1	4.5

CHAIN

mm

PITCH	12.7
INNER WIDTH	4.88
ROLLER - \emptyset	7.75

MATERIAL: C 45 UNI 7845

Z	d_e	d_p	SINGLE		
			d_m	D_1	A
8	38.5	33.18	21	8	14
9	41.5	37.13	25	8	14
10	46.2	41.10	28	8	14
11	49.6	45.07	31	8	16
12	53.9	49.07	35	8	16
13	58.4	53.06	39	8	16
14	62.8	57.07	43	8	16
15	66.8	61.09	47	8	16
16	70.9	65.10	50	10	18
17	74.9	69.11	50	10	18
18	78.9	73.14	50	10	18
19	82.9	77.16	50	10	18
20	88.9	81.19	50	10	18
21	91.0	85.22	60	12	20
22	95.0	89.24	60	12	20
23	99.0	93.27	60	12	20
24	103.0	97.29	60	12	20
25	107.1	101.33	60	12	20
26	111.2	105.36	70	16	20
27	115.4	109.40	70	16	20
28	119.4	113.42	70	16	20
29	123.4	117.46	70	16	20
30	127.5	121.50	70	16	20
31	131.5	125.54	70	16	20
32	135.5	129.56	70	16	20
33	139.6	133.60	70	16	20
34	143.6	137.64	70	16	20
35	147.6	141.68	70	16	20
36	151.7	145.72	70	16	25
37	155.7	149.76	70	16	25
38	159.8	153.80	70	16	25
39	163.8	157.83	70	16	25
40	167.8	161.87	70	16	25

P L A T E W H E E L S

1/2" x 3/16"

for roller chains in compliance with DIN 8187 ISO/R 606

The plate size is increased by $h = 6$ mm starting from Z.90

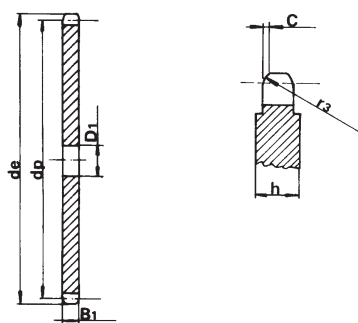

PLATEWHEEL

mm

TOOTH RADIUS r_3	13
RADIUS WIDTH C	1.3
PLATE TOOTH WIDTH B_1	4.3 ± 0.2

CHAIN

mm

PITCH	12.7
INNER WIDTH	4.88
ROLLER - \emptyset	7.75

Z	d_e	d_p	S		S		
			D_1		D_1		
8	38.5	33.18	8	43	179.5	173.99	16
9	41.5	37.13	8	44	183.5	178.03	16
10	46.2	41.10	8	45	187.5	182.07	16
11	49.6	45.07	8	46	191.6	186.10	20
12	53.9	49.07	8	47	195.6	190.14	20
13	58.4	53.06	8	48	199.7	194.18	20
14	62.8	57.07	8	49	203.7	198.22	20
15	66.8	61.09	8	50	207.8	202.26	20
16	70.9	65.10	10	51	211.8	206.30	20
17	74.9	69.11	10	52	215.9	210.34	20
18	78.9	73.14	10	53	219.9	214.37	20
19	82.9	77.16	10	54	224.0	218.43	20
20	86.9	81.19	10	55	228.0	222.46	20
21	91.0	85.22	10	56	232.1	226.50	20
22	95.0	89.24	10	57	236.1	230.54	20
23	99.0	93.27	10	58	240.2	234.58	20
24	103.0	97.29	10	59	244.2	238.62	20
25	107.1	101.33	10	60	248.2	242.66	20
26	111.2	105.36	12	62	256.7	250.75	20
27	115.4	109.40	12	64	264.8	258.82	20
28	119.4	113.42	12	65	268.8	262.86	20
29	123.4	117.46	12	66	272.9	266.90	25
30	127.5	121.50	12	68	280.9	274.99	25
31	131.5	125.54	12	70	289.0	283.07	25
32	135.5	129.56	12	72	297.1	291.16	25
33	139.6	133.60	12	76	313.3	307.33	25
34	143.6	137.64	12	78	321.4	315.40	25
35	147.6	141.68	12	80	329.4	323.48	25
36	151.7	145.72	16	85	349.7	343.70	25
37	155.7	149.76	16	90	369.9	363.90	25
38	159.8	153.80	16	95	390.1	384.10	25
39	163.8	157.83	16	100	410.3	404.31	25
40	167.8	161.87	16	110	450.7	444.74	25
41	171.4	165.91	16	114	466.9	460.90	25
42	175.4	169.95	16	120	491.2	485.16	25
				125	511.4	505.37	25

S P R O C K E T S

1/2" x 1/4" - 7.75 roller size

for roller chains in compliance with DIN 8187 ISO/R 606

Z	d _e	d _p	SINGLE		
			d _m	D ₁	A
8	38.5	33.18	20	10	25
9	41.5	37.13	24	10	25
10	46.2	41.10	26	10	25
11	49.6	45.07	29	10	25
12	53.9	49.07	33	10	28
13	58.4	53.06	37	10	28
14	62.8	57.07	41	10	28
15	66.8	61.09	45	10	28
16	70.9	65.10	50	12	28
17	74.9	69.11	52	12	28
18	78.9	73.14	56	12	28
19	82.9	77.16	60	12	28
20	86.9	81.19	64	12	28
21	91.0	85.22	68	14	28
22	95.0	89.24	70	14	28
23	99.0	93.27	70	14	28
24	103.0	97.29	70	14	28
25	107.1	101.33	70	14	28
26	111.2	105.36	70	16	30
27	115.4	109.40	70	16	30
28	119.4	113.42	70	16	30
29	123.4	117.46	80	16	30
30	127.5	121.50	80	16	30
31	131.5	125.54	90	16	30
32	135.5	129.56	90	16	30
33	139.6	133.60	90	16	30
34	143.6	137.64	90	16	30
35	147.6	141.68	90	16	30
36	151.7	145.72	90	16	35
37	155.7	149.76	90	16	35
38	159.8	153.80	90	16	35
39	163.8	157.83	90	16	35
40	167.8	161.87	90	16	35

Sprocket sizes subject to availability

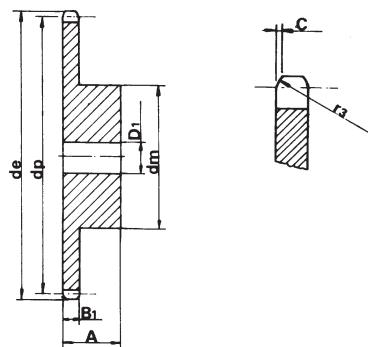

SPROCKET

mm

TOOTH RADIUS r ₃	13
RADIUS WIDTH C	1.3
SPROCKET TOOTH WIDTH B ₁	5.9

CHAIN

mm

PITCH	12.7
INNER WIDTH	6.4
ROLLER - Ø	7.75

MATERIAL: C 45 UNI 7845

P L A T E W H E E L S

1/2" x 1/4" - 7.75 roller size

for roller chains in compliance with DIN 8187 ISO/R 606

Z	d _e	d _p	S		Z	d _e	d _p	D ₁
			D ₁	S				
8	38.5	33.18	8	8	43	179.5	173.99	16
9	41.5	37.13	8	8	44	183.5	178.03	16
10	46.2	41.10	8	8	45	187.5	182.07	16
11	49.6	45.07	8	8	46	191.6	186.10	20
12	53.9	49.07	8	8	47	195.6	190.14	20
13	58.4	53.06	8	8	48	199.7	194.18	20
14	62.8	57.07	8	8	49	203.7	198.22	20
15	66.8	61.09	8	8	50	207.8	202.26	20
16	70.9	65.10	10	10	51	211.8	206.30	20
17	74.9	69.11	10	10	52	215.9	210.34	20
18	78.9	73.14	10	10	53	219.9	214.37	20
19	82.9	77.16	10	10	54	224.0	218.43	20
20	86.9	81.19	10	10	55	228.0	222.46	20
21	91.0	85.22	10	10	56	232.1	226.50	20
22	95.0	89.24	10	10	57	236.1	230.54	20
23	99.0	93.27	10	10	58	240.2	234.58	20
24	103.0	97.29	10	10	59	244.2	238.62	20
25	107.1	101.33	10	10	60	248.2	242.66	20
26	111.2	105.36	12	12	62	256.7	250.75	20
27	115.4	109.40	12	12	64	264.8	258.82	20
28	119.4	113.42	12	12	65	268.8	262.86	20
29	123.4	117.46	12	12	66	272.9	266.90	25
30	127.5	121.50	12	12	68	280.9	274.99	25
31	131.5	125.54	12	12	70	289.0	283.07	25
32	135.5	129.56	12	12	72	297.1	291.16	25
33	139.6	133.60	12	12	76	313.3	307.33	25
34	143.6	137.64	12	12	78	321.4	315.40	25
35	147.6	141.68	12	12	80	329.4	323.48	25
36	151.7	145.72	16	16	85	349.7	343.70	25
37	155.7	149.76	16	16	90	369.9	363.90	25
38	159.8	153.80	16	16	95	390.1	384.10	25
39	163.8	157.83	16	16	100	410.3	404.31	25
40	167.8	161.87	16	16	110	450.7	444.74	25
41	171.4	165.91	16	16	114	466.9	460.90	25
42	175.4	169.95	16	16	120	491.2	485.16	25
					125	511.4	505.37	25

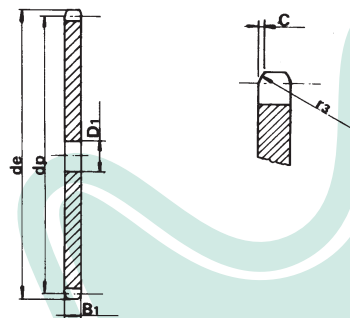

PLATEWHEEL

mm

TOOTH RADIUS r ₃	13
RADIUS WIDTH C	1.3
PLATE TOOTH WIDTH B ₁	5.9

CHAIN

mm

PITCH	12.7
INNER WIDTH	6.4
ROLLER - Ø	7.75

S P R O C K E T S

1/2" x 1/4" - 8.51 roller size

for roller chains in compliance with DIN 8187 ISO/R 606

Z	d _e	d _p	SINGLE		
			d _m	D ₁	A
8	37.2	33.18	20	10	25
9	41.0	37.13	24	10	25
10	45.2	41.10	26	10	25
11	48.7	45.07	29	10	25
12	53.0	49.07	33	10	28
13	57.4	53.06	37	10	28
14	61.8	57.07	41	10	28
15	65.5	61.09	45	10	28
16	69.5	65.10	50	12	28
17	73.6	69.11	52	12	28
18	77.8	73.14	56	12	28
19	81.7	77.16	60	12	28
20	85.8	81.19	64	12	28
21	89.7	85.22	68	14	28
22	93.8	89.24	70	14	28
23	98.2	93.27	70	14	28
24	101.8	97.29	70	14	28
25	105.8	101.33	70	14	28
26	110.0	105.36	70	16	30
27	114.0	109.40	70	16	30
28	118.0	113.42	70	16	30
29	122.0	117.46	80	16	30
30	126.1	121.50	80	16	30
31	130.2	125.54	90	16	30
32	134.3	129.56	90	16	30
33	138.4	133.60	90	16	30
34	142.6	137.64	90	16	30
35	146.7	141.68	90	16	30
36	151.0	145.72	90	16	35
37	154.6	149.76	90	16	35
38	158.6	153.80	90	16	35
39	162.7	157.83	90	16	35
40	166.8	161.87	90	16	35

Pignoni ad esaurimento

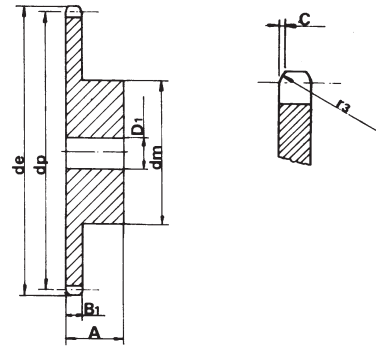

SPROCKET

	mm
TOOTH RADIUS r ₃	13
RADIUS WIDTH C	1.3
SPROCKET TOOTH WIDTH B ₁	5.9

CHAIN

	mm
PITCH	12.7
INNER WIDTH	6.4
ROLLER - Ø	8.51

MATERIAL: C 45 UNI 7845

P L A T E W H E E L S

1/2" x 1/4" - 8.51 roller size

for roller chains in compliance with DIN 8187 ISO/R 606

Z	d _e	d _p	S				
			D ₁	Z	d _e	d _p	D ₁
8	37.2	33.18	8	43	179.7	173.99	16
9	41.0	37.13	8	44	183.8	178.03	16
10	45.2	41.10	8	45	188.0	182.07	16
11	48.7	45.07	8	46	192.1	186.10	20
12	53.0	49.07	8	47	196.2	190.14	20
13	57.4	53.06	8	48	200.3	194.18	20
14	61.8	57.07	8	49	204.3	198.22	20
15	65.5	61.09	8	50	208.3	202.26	20
16	69.5	65.10	10	51	212.1	206.30	20
17	73.6	69.11	10	52	216.1	210.34	20
18	77.8	73.14	10	53	220.2	214.37	20
19	81.7	77.16	10	54	224.1	218.43	20
20	85.8	81.19	10	55	228.1	222.46	20
21	89.7	85.22	10	56	232.2	226.50	20
22	93.8	89.24	10	57	236.4	230.54	20
23	98.2	93.27	10	58	240.5	234.58	20
24	101.8	97.29	10	59	244.5	238.62	20
25	105.8	101.33	10	60	248.6	242.66	20
26	110.0	105.36	12	62	256.9	250.75	20
27	114.0	109.40	12	64	265.1	258.82	20
28	118.0	113.42	12	65	269.0	262.86	20
29	122.0	117.46	12	66	273.0	266.90	25
30	126.1	121.50	12	68	281.0	274.99	25
31	130.2	125.54	12	70	289.0	283.07	25
32	134.2	129.56	12	72	297.2	291.16	25
33	138.4	133.60	12	76	313.3	307.33	25
34	142.6	137.64	12	78	321.4	315.40	25
35	146.7	141.68	12	80	329.4	323.48	25
36	151.0	145.72	16	85	349.0	343.70	25
37	154.6	149.76	16	90	369.9	363.90	25
38	158.6	153.80	16	95	390.1	384.10	25
39	162.7	157.83	16	100	410.3	404.31	25
40	166.8	161.87	16	110	450.7	444.74	25
41	171.4	165.91	16	114	466.9	460.90	25
42	175.4	169.95	16	120	491.2	485.16	25
				125	511.3	505.37	25

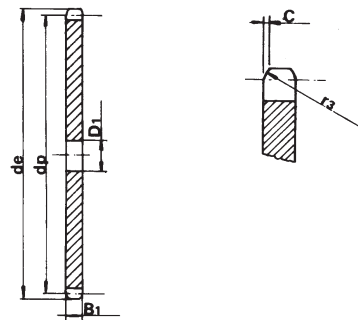

PLATEWHEEL

	mm
TOOTH RADIUS r ₃	13
RADIUS WIDTH C	1.3
PLATE TOOTH WIDTH B ₁	5.9

CHAIN

	mm
PITCH	12.7
INNER WIDTH	6.4
ROLLER - Ø	8.51

S P R O C K E T S

Z	d _e	d _p	SINGLE			DOUBLE			TRIPLE		
			d _m	D ₁	A	d _m	D ₁	A	d _m	D ₁	A
8	115.0	99.55	58	20	45	58	25	95	58	25	140
9	126.4	111.40	70	20	45	70	25	95	70	25	140
10	138.0	123.29	80	20	45	80	25	95	80	25	140
11	150.0	135.21	90	25	50	90	25	100	90	25	150
12	162.0	147.22	102	25	50	102	25	100	102	25	150
13	174.2	159.18	114	25	50	114	25	100	114	25	150
14	186.2	171.22	128	25	50	128	25	100	128	25	150
15	198.2	183.26	140	25	50	140	25	100	140	25	150
16	210.3	195.30	*140	25	55	*140	25	100	*140	25	150
17	222.3	207.34	*140	25	55	*150	25	100	*150	25	150
18	234.3	219.42	*140	25	55	*160	25	100	*160	25	150
19	246.5	231.49	*140	25	55	*160	25	100	*160	25	150
20	258.6	243.57	*140	25	55	*160	25	100	*160	25	150
21	270.6	255.65	*150	25	60	*160	25	100	*160	30	150
22	282.7	267.73	*150	25	60	*160	25	100	*160	30	150
23	294.8	279.80	*150	25	60	*160	25	100	*160	30	150
24	306.8	291.88	*150	25	60	*160	25	100	*160	30	150
25	319.0	304.00	*150	25	60	*160	25	100	*160	30	150
26	331.0	316.08	*160	30	60	*160	30	100	*160	30	150
27	343.2	328.19	*160	30	60	*160	30	100	*160	30	150
28	355.2	340.27	*160	30	60	*160	30	100	*160	30	150
29	367.3	352.38	*160	30	60	*160	30	100	*160	30	150
30	379.5	364.50	*160	30	60	*160	30	100	*160	40	150
31	391.6	376.62	*160	30	60	*170	30	100			
32	403.7	388.69	*160	30	60	*170	30	100	*170	40	150
33	415.8	400.81	*160	30	60	*170	30	100	*170	40	150
34	427.8	412.93	*160	30	60	*170	30	100	*170	40	150
35	440.0	425.04	*160	30	60	*170	30	100	*170	40	150
36	452.0	437.16	*160	30	60	*170	30	100	*170	40	150
37	464.2	449.27	*160	30	60	*170	30	100			
38	476.2	461.39	*160	30	60	*170	30	100	*170	40	150
39	488.5	473.50	*160	30	60	*170	30	100			
40	500.6	485.62	*160	30	60	*170	30	100	*170	40	150

1" 1/2 x 1"

for roller chains in compliance with
DIN 8187 ISO/R 606

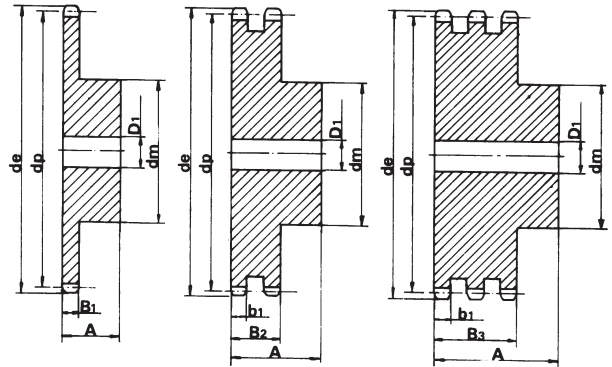
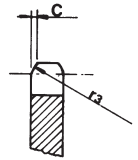

SPROCKET

TOOTH RADIUS r ₃	38
RADIUS WIDTH C	4
SPROCKET WIDTH B ₁	24.1
SPROCKET TOOTH WIDTH b ₁	23.6
SPROCKET TOOTH WIDTH B ₂	72
SPROCKET TOOTH WIDTH B ₃	120.3

CHAIN

PITCH	38.1
INNER WIDTH	25.4
ROLLER - Ø	25.4

MATERIAL: C 45 UNI 7845 *MATERIAL: FE - WITH WELDED HUB

P L A T E W H E E L S

Z	d _e	d _p	S D T			Z	d _e	d _p	S D T		
			D ₁	D ₂	D ₃				D ₁	D ₂	D ₃
8	115.0	99.55	20	25	25	43	536.8	521.97	30		
9	126.4	111.40	20	25	25	44	549.0	534.08	30		
10	138.0	123.29	20	25	25	45	561.2	546.20	30	40	40
11	150.0	135.21	20	25	25	46	573.3	558.32	30	40	40
12	162.0	147.22	20	25	25	47	585.4	570.43	30		
13	174.2	159.18	20	25	25	48	597.4	582.55	30	40	40
14	186.2	171.22	20	25	25	49	609.5	594.66	30		
15	198.2	183.26	20	25	25	50	621.7	606.78	30	40	40
16	210.3	195.30	25	25	25	51	633.8	618.89	30		
17	222.3	207.34	25	25	25	52	646.0	631.01	30		
18	234.3	219.42	25	25	25	53	658.0	643.13	30		
19	246.5	231.49	25	25	25	54	670.2	655.28	30		
20	258.6	243.57	25	25	25	55	682.3	667.40	30	40	40
21	270.6	255.65	25	25	30	56	694.4	679.51	30		
22	282.7	267.73	25	25	30	57	706.5	691.63	30	40	40
23	294.8	279.80	25	25	30	58	718.6	703.74	30		
24	306.8	291.88	25	25	30	59	730.7	715.86	30		
25	319.0	304.00	25	25	30	60	742.8	727.97	30	40	40
26	331.0	316.08	30	30	30	62	767.2	752.24	40		
27	343.2	328.19	30	30	30	64	791.3	776.48	40		
28	355.2	340.27	30	30	30	65	803.4	788.59	40	40	40
29	367.3	352.38	30	30	30	66	815.6	800.71	40		
30	379.5	364.50	30	30	40	68	839.8	824.98	40		
31	391.6	376.62	30	30		70	864.2	849.21	40		
32	403.7	388.69	30	30	40	72	888.4	873.48	40		
33	415.8	400.81	30	30	40	75	924.8	909.83	40		
34	427.8	412.93	30	30	40	76	936.9	921.98	40	40	40
35	440.0	425.04	30	30	40	80	985.4	970.44	40		
36	452.0	437.16	30	30	40	85	1046.0	1031.10	40		
37	464.2	449.27	30	30		95	1167.3	1152.33	40		
38	476.2	461.39	30	30	40						
39	488.5	473.50	30	30							
40	500.6	485.62	30	30	40						
41	512.6	497.74	30								
42	524.7	509.85	30	40	40						

1" 1/2 x 1"

for roller chains in compliance with
DIN 8187 ISO/R 606

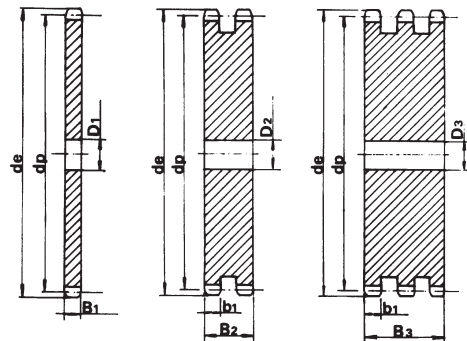
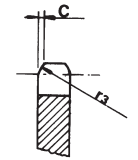

PLATEWHEEL

TOOTH RADIUS r ₃	38
RADIUS WIDTH C	4
PLATE TOOTH WIDTH B ₁	24.1
PLATE TOOTH WIDTH b ₁	23.6
PLATE TOOTH WIDTH B ₂	72
PLATE TOOTH WIDTH B ₃	120.3

CHAIN

PITCH	38.1
INNER WIDTH	25.4
ROLLER - Ø	25.4

S P R O C K E T S

1" 3/4 x 1" 1/4

for roller chains in compliance with
DIN 8187 ISO/R 606

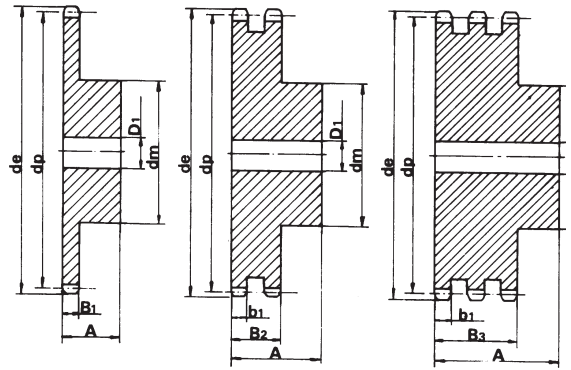
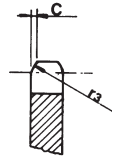

SPROCKET

TOOTH RADIUS r_3	44
RADIUS WIDTH C	5
SPROCKET TOOTH WIDTH B_1	29.4
SPROCKET TOOTH WIDTH b_1	28.8
SPROCKET TOOTH WIDTH B_2	88.4
SPROCKET TOOTH WIDTH B_3	148

CHAIN

PITCH	44.45
INNER WIDTH	30.99
ROLLER - \emptyset	27.94

MATERIAL: C 45 UNI 7845 *MATERIAL: FE - WITH WELDED HUB

Z	d_e	d_p	SINGLE			DOUBLE			TRIPLE		
			d_m	D_1	A	d_m	D_1	A	d_m	D_1	A
8	132.0	116.15	74	25	70	74	25	120	74	30	180
9	148.4	129.96	88	25	70	88	25	120	88	30	180
10	162.3	143.85	100	25	70	100	25	120	100	30	180
11	176.3	157.77	112	25	70	112	25	120	112	30	180
12	189.5	171.74	125	25	70	125	25	120	125	30	180
13	204.2	185.75	*130	25	70	*130	25	120	*130	30	180
14	218.2	199.76	*130	25	70	*130	25	120	*130	30	180
15	232.3	213.79	*145	25	70	*145	25	120	*145	30	180
16	246.3	227.84	*160	30	75	*160	30	120	*160	30	180
17	260.0	241.91	*160	30	75	*160	30	120	*160	30	180
18	274.0	255.98	*160	30	75	*160	30	120	*160	30	180
19	289.0	270.06	*160	30	75	*180	30	120	*180	30	180
20	303.0	284.15	*160	30	75	*180	30	120	*180	30	180
21	317.0	298.24	*170	30	75	*180	30	120	*180	30	180
22	331.0	312.34	*170	30	75	*180	30	120	*180	30	180
23	345.0	326.44	*170	30	75	*180	30	120	*180	30	180
24	359.0	340.55	*170	30	75	*180	30	120	*180	30	180
25	373.0	354.66	*170	30	75	*180	30	120	*180	40	180
26	387.0	368.77	*170	30	75	*180	30	120	*180	40	180
27	401.4	382.88	*170	30	75	*180	30	120	*180	40	180
28	416.0	397.00	*170	30	75	*180	30	120	*180	40	180
29	430.0	411.12	*170	30	75	*180	30	120	*180	40	180
30	444.0	425.24	*170	30	75	*180	30	120	*180	40	180
31	458.0	439.37	*180	30	75						
32	472.0	453.49	*180	30	75						
33	486.0	467.62	*180	30	75						
34	500.0	481.75	*180	30	75						
35	514.0	495.88	*180	30	75	*200	30	120	*200	40	180
36	529.0	510.01	*180	30	75						
37	543.0	524.14	*180	30	75						
38	557.0	538.27	*180	30	75	*200	30	120	*200	40	180
39	571.0	552.40	*180	30	75						
40	585.0	566.54	*180	30	75	*200	30	120	*200	40	180

P L A T E W H E E L S

1" 3/4 x 1" 1/4

for roller chains in compliance with
DIN 8187 ISO/R 606

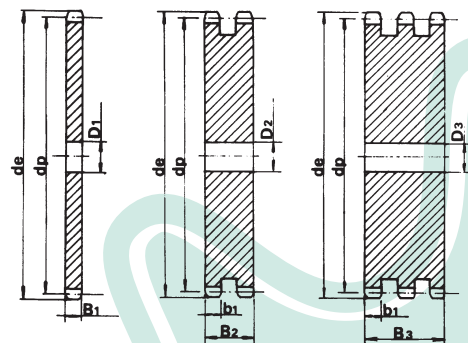
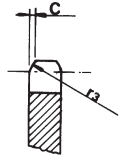

PLATEWHEEL

TOOTH RADIUS r_3	44
RADIUS WIDTH C	5
PLATE TOOTH WIDTH B_1	29.4
PLATE TOOTH WIDTH b_1	28.3
PLATE TOOTH WIDTH B_2	88.4
PLATE TOOTH WIDTH B_3	148

CHAIN

PITCH	44.45
INNER WIDTH	30.99
ROLLER - \emptyset	27.94

Z	d_e	d_p	S D T			Z	d_e	d_p	S D T		
			D_1	D_2	D_3				D_1	D_2	D_3
8	132.0	116.15	25	25	25	57	825.0	806.90	40	40	40
9	148.4	129.96	25	25	25	60	869.0	849.32	40	40	40
10	162.3	143.85	25	25	25	76	1095.0	1075.62	40	40	40
11	176.3	157.77	25	25	30						
12	189.5	171.74	25	25	30						
13	204.2	185.75	25	25	30						
14	218.2	199.76	25	25	30						
15	232.3	213.79	25	25	30						
16	246.3	227.84	30	30	30						
17	260.0	241.91	30	30	30						
18	274.0	255.98	30	30	30						
19	289.0	270.06	30	30	30						
20	303.0	284.15	30	30	30						
21	317.0	298.24	30	30	30						
22	331.0	312.34	30	30	30						
23	345.0	326.44	30	30	30						
24	359.0	340.55	30	30	30						
25	373.0	354.66	30	30	40						
26	387.0	368.77	30	30	40						
27	401.4	382.88	30	30	40						
28	416.0	397.00	30	30	40						
29	430.0	411.12	30	30	40						
30	444.0	425.24	30	30	40						
31	458.0	439.37	30								
32	472.0	453.49	30								
33	486.0	467.62	30								
34	500.0	481.75	30								
35	514.0	495.88	30	30	40						
36	529.0	510.01	30								
37	543.0	524.14	30								
38	557.0	538.27	30	30	40						
39	571.0	552.40	30								
40	585.0	566.54	30	30	40						
45	656.0	637.22	30	30	40						
50	726.0	707.91	30	30	40						

S P R O C K E T S

2" x 1" 1/4

for roller chains in compliance with
DIN 8187 ISO/R 606

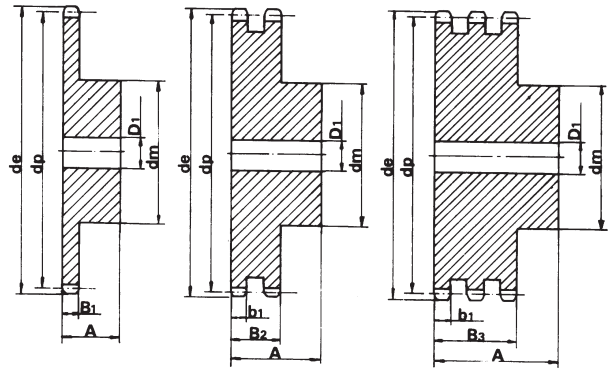
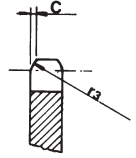

SPROCKET

	mm
TOOTH RADIUS r_3	51
RADIUS WIDTH C	5
SPROCKET TOOTH WIDTH B_1	29.4
SPROCKET TOOTH WIDTH b_1	28.8
SPROCKET TOOTH WIDTH B_2	87.4
SPROCKET TOOTH WIDTH B_3	146

CHAIN

	mm
PITCH	50.8
INNER WIDTH	30.99
ROLLER - \varnothing	29.21

MATERIAL: C 45 UNI 7845 *MATERIAL: FE - WITH WELDED HUB

Z	d_e	d_p	SINGLE			DOUBLE			TRIPLE		
			d_m	D_1	A	d_m	D_1	A	d_m	D_1	A
8	153.2	132.69	82	25	80	82	30	120	82	30	180
9	169.0	148.54	88	25	80	88	30	120	88	30	180
10	185.0	164.44	104	25	80	104	30	120	104	30	180
11	200.8	180.34	120	30	80	120	30	120	120	30	180
12	216.8	196.29	*133	30	80	*133	30	120	*133	30	180
13	232.8	212.29	*145	30	80	*145	30	120	*145	30	180
14	248.8	228.29	*160	30	80	*160	30	120	*160	30	180
15	264.8	244.30	*160	30	80	*160	30	120	*160	30	180
16	280.9	260.40	*160	30	90	*160	30	120	*160	30	180
17	296.9	276.40	*170	30	90	*180	30	120	*180	30	180
18	313.0	292.55	*170	30	90	*180	30	120	*180	30	180
19	329.1	308.66	*170	30	90	*200	30	120	*200	30	180
20	345.2	324.71	*180	30	90	*200	30	120	*200	30	180
21	361.3	340.82	*180	30	90	*200	30	120	*200	40	180
22	377.5	356.98	*180	30	90	*200	30	120	*200	40	180
23	393.6	373.08	*180	30	90	*200	30	120	*200	40	180
24	409.7	389.18	*180	30	90	*200	30	120	*200	40	180
25	425.8	405.33	*180	30	90	*200	30	120	*200	40	180
26	441.9	421.44	*180	30	90	*200	30	120	*200	40	180
27	458.1	437.59	*180	30	90	*200	30	120	*200	40	180
28	474.2	453.69	*180	30	90	*200	30	120	*200	40	180
29	490.4	469.90	*180	30	90						
30	506.5	486.00	*180	30	90	*200	30	120	*200	40	180
32	538.8	518.28	*180	30	90						
35	589.5	566.72	*180	30	90						
38	635.5	615.14	*180	30	90						
40	670.3	647.49	*180	30	90						

P L A T E W H E E L S

2" x 1" 1/4

for roller chains in compliance with
DIN 8187 ISO/R 606

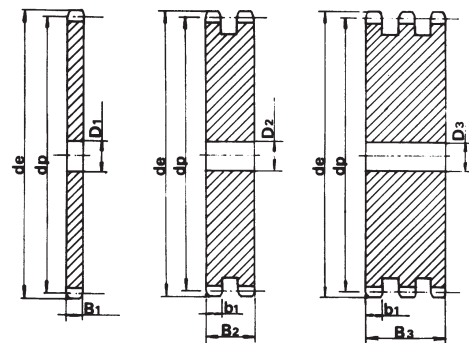
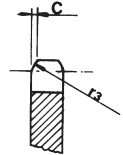

PLATEWHEEL

	mm
TOOTH RADIUS r_3	51
RADIUS WIDTH C	5
PLATE TOOTH WIDTH B_1	29.4
PLATE TOOTH WIDTH b_1	28.8
PLATE TOOTH WIDTH B_2	87.4
PLATE TOOTH WIDTH B_3	146

CHAIN

	mm
PITCH	50.8
INNER WIDTH	30.99
ROLLER - \varnothing	29.21

Z	d_e	d_p	S D T			Z	d_e	d_p	S D T		
			D_1	D_2	D_3				D_1	D_2	D_3
8	153.2	132.69	25	25	25	76	1252.0	1229.28	40	40	40
9	169.0	148.54	25	25	25						
10	185.0	164.44	25	25	25						
11	200.8	180.34	30	30	30						
12	216.8	196.29	30	30	30						
13	232.8	212.29	30	30	30						
14	248.8	228.29	30	30	30						
15	264.8	244.30	30	30	30						
16	280.9	260.40	30	30	30						
17	296.9	276.40	30	30	30						
18	313.0	292.55	30	30	30						
19	329.1	308.66	30	30	30						
20	345.2	324.71	30	30	30						
21	361.3	340.82	30	30	40						
22	377.5	356.98	30	30	40						
23	393.6	373.08	30	30	40						
24	409.7	389.18	30	30	40						
25	425.8	405.33	30	30	40						
26	441.9	421.44	30	30	40						
27	458.1	437.59	30	30	40						
28	474.2	453.69	30	30	40						
29	490.4	469.90	30								
30	506.5	486.00	30	30	40						
32	538.8	518.26	30								
35	589.5	566.72	30	30	40						
38	635.5	615.14	30	30	40						
40	670.3	647.49	40	40	40						
45	751.0	728.26	40	40	40						
50	831.8	809.04	40	40	40						
57	945.0	922.17	40	40	40						
60	993.4	970.63	40	40	40						

SPROCKETS

Z	d _e	d _p	SINGLE			DOUBLE			d _m	D ₁	A
			d _m	D ₁	A	d _m	D ₁	A			
10	35.70	30.82	20	8	22						
11	38.69	33.80	22	8	25						
12	41.68	36.80	25	8	25						
13	44.68	39.80	28	10	25	28	10	25			
14	47.68	42.80	31	10	25	31	10	25			
15	50.69	45.81	34	10	25	34	10	25			
16	53.70	48.82	37	10	28	37	12	30			
17	56.72	51.83	38	10	28	40	12	30			
18	59.73	54.85	38	10	28	43	12	30			
19	62.75	57.87	46	10	28	46	12	30			
20	65.77	60.89	46	10	28	49	12	30			
21	68.79	63.91	46	10	28	52	12	30			
22	71.81	66.93	52	12	28	55	12	30			
23	74.83	69.95	52	12	28	58	12	30			
24	77.85	72.97	52	12	28	61	12	30			
25	80.88	76.00	58	12	28	64	12	30			
26	83.90	79.02	58	12	28	67	12	30			
27	86.93	82.04	58	12	28	70	12	30			
28	89.95	85.07	60	12	28	73	12	30			
30	96.00	91.12	60	12	28						

PLATEWHEELS

Z	d _e	d _p	S			D			T		
			D ₁	D ₂	D ₃						
30	96.00	91.12					12				
32	102.06	97.17	12								
36	114.17	109.29	12								
38	120.22	115.34	12	14							
40	126.28	121.40	12								
45	141.43	136.55	16	16							
48	150.52	145.64	16								
57	177.79	172.91	16	16							
76	235.37	230.49	20	20							

SPROCKETS

Z	d _e	d _p	SINGLE			DOUBLE			TRIPLE		
			d _m	D ₁	A	d _m	D ₁	A	d _m	D ₁	A
10	47.66	41.10	26	10	25						
11	51.64	45.08	29	10	25						
12	55.63	49.07	35	10	28						
13	59.63	53.07	35	10	28	38	12	35	35	14	50
14	63.63	57.07	35	10	28	42	12	35	42	14	50
15	67.64	61.08	46	10	28	46	12	35	46	14	50
16	71.66	65.10	48	10	28	50	14	35	50	16	50
17	75.68	69.12	48	10	28	54	14	35	54	16	50
18	79.70	73.14	58	12	28	58	14	35	58	16	50
19	83.72	77.16	60	12	28	62	14	35	62	16	50
20	87.74	81.18	60	12	28	66	14	35	66	16	50
21	91.77	85.21	65	12	28	70	16	40	70	20	55
22	95.80	89.24	65	12	28	70	16	40	70	20	55
23	99.83	93.27	65	12	28	70	16	40	70	20	55
24	103.86	97.30	70	14	28	75	16	40	75	20	55
25	107.89	101.33	70	14	28	80	16	40	80	20	55
26	111.92	105.36	70	14	28	85	20	40	85	20	55
27	115.96	109.40	70	16	30	85	20	40	85	20	55
28	119.99	113.43	70	16	30	90	20	40	90	20	55
30	128.06	121.50	80	16	30	100	20	40			
32	136.13	129.57	80	16	30						
35	148.24	141.68	90	16	30						
36	152.28	145.72	90	16	30						
38	160.35	153.79	90	16	35						
40	168.43	161.87	90	16	35						

PLATEWHEELS

Z	d _e	d _p	S			D			T		
			D ₁	D ₂	D ₃						
30	128.06	121.50					20				
32	136.13	129.57					16				
38	160.35	153.79					20	25			
40	168.43	161.87					20				
42	176.50	169.94	20								
45	188.62	182.06	20	20	25						
48	200.74	194.18	20								
57	237.10	230.54	20	25	25						
76	313.88	307.32	25	25	25						
95	390.67	384.11					25				

Pitch 3/8" x 3/16"

for roller chains in compliance with
DIN 8188-ISO/R 606 - ANSI B 29.1

SPROCKET

TOOTH RADIUS r ₃	10
RADIUS WIDTH C	1.2
SPROCKET TOOTH WIDTH B ₁	4.4
SPROCKET TOOTH WIDTH b ₁	4.3
SPROCKET TOOTH WIDTH B ₂	14.4

CHAIN

PITCH	9.525
INNER WIDTH	4.77
ROLLER - ø	5.08

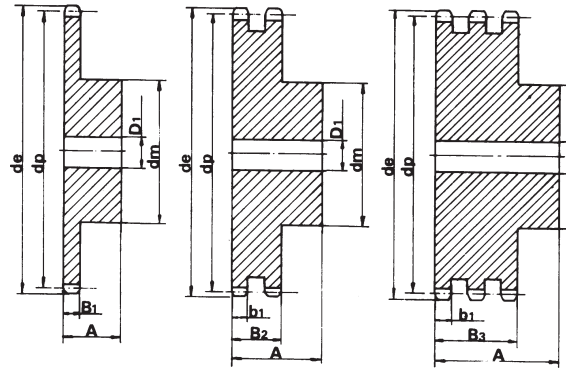

MATERIAL: C 45 UNI 7845 SPROCKETS

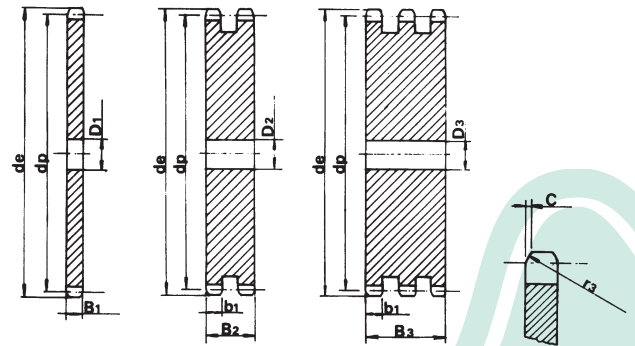

Pitch 1/2" x 5/16"

for roller chains in compliance with
DIN 8188-ISO/R 606 - ANSI B 29.1

CORONA

TOOTH RADIUS r ₃	13.5
RADIUS WIDTH C	1.6
PLATE TOOTH WIDTH B ₁	7.4
PLATE TOOTH WIDTH b ₁	7.2
PLATE TOOTH WIDTH B ₂	21.6
PLATE TOOTH WIDTH B ₃	36

CATENA

PITCH	12.7
INNER WIDTH	7.94
ROLLER - ø	7.94

MATERIAL C 45 UNI 7845 SPROCKETS

S P R O C K E T S

ASA 50

Z	d _e	d _p	SINGLE			DOUBLE			TRIPLE		
			d _m	D ₁	A	d _m	D ₁	A	d _m	D ₁	A
8	47.0	41.48	25	10	25						
9	52.6	46.42	30	10	25						
10	57.5	51.37	35	10	25						
11	63.0	56.34	37	12	30						
12	68.0	61.34	42	12	30				44	16	55
13	73.0	66.32	47	12	30	49	14	40	49	16	55
14	78.0	71.34	52	12	30	54	14	40	54	16	55
15	83.0	76.36	57	12	30	59	14	40	59	16	55
16	88.0	81.37	60	12	30	64	16	45	64	16	60
17	93.0	86.39	60	12	30	69	16	45	69	16	60
18	98.3	91.42	70	14	30	74	16	45	74	16	60
19	103.3	96.45	70	14	30	79	16	45	79	16	60
20	108.4	101.49	75	14	30	84	16	45	84	16	60
21	113.4	106.52	75	16	30	85	16	45	85	20	60
22	118.0	111.55	80	16	30	90	16	45	90	20	60
23	123.4	116.58	80	16	30	95	16	45	95	20	60
24	128.3	121.62	80	16	30	100	16	45	100	20	60
25	134.0	126.66	80	16	30	105	16	45	105	20	60
26	139.0	131.70	85	20	35				110	20	60
27	144.0	136.75	85	20	35				110	20	60
28	148.7	141.78	90	20	35				115	20	60
29	153.8	146.83	90	20	35						
30	158.8	151.87	90	20	35						
31	163.9	156.92	95	20	35						
32	168.9	161.95	95	20	35						
33	174.5	167.00	95	20	35						
34	179.0	172.05	95	20	35						
35	184.1	177.10	95	20	35						
36	189.1	182.15	100	20	35						
37	194.2	187.20	100	20	35						
38	199.2	192.24	100	20	35						
39	204.2	197.29	100	20	35						
40	209.3	202.34	100	20	35						

Pitch 5/8" x 3/8"

for roller chains in compliance with
DIN 8188-ISO/R 606 - ANSI B 29.1

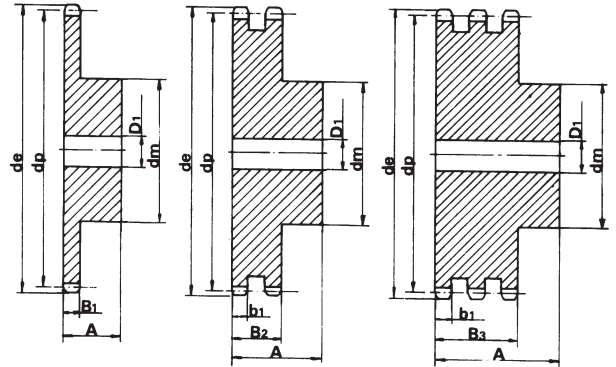
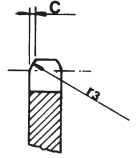

SPROCKET

TOOTH RADIUS r ₃	17
RADIUS WIDTH C	2
SPROCKET TOOTH WIDTH B ₁	9
SPROCKET TOOTH WIDTH b ₁	8.8
SPROCKET TOOTH WIDTH B ₂	26.9
SPROCKET TOOTH WIDTH B ₃	45

CHAIN

PITCH	15.875
INNER WIDTH	9.52
ROLLER - Ø	10.16

MATERIAL: C 45 UNI 7845

P L A T E W H E E L S

ASA 50

Z	d _e	d _p	S D T			Z	d _e	d _p	S D T		
			D ₁	D ₂	D ₃				D ₁	D ₂	D ₃
8	47.0	41.48	10			44	230.0	222.53	20		
9	52.6	46.42	10			45	235.0	227.58	20	20	25
10	57.5	51.37	10			46	240.1	232.63	20		
11	63.0	56.34	10			47	245.1	237.68	20		
12	68.0	61.34	10			48	250.2	242.73	20		
13	73.0	66.32	10			49	255.2	247.78	20		
14	78.0	71.34	10			50	260.3	252.82	20		
15	83.0	76.36	10			51	265.3	257.87	20		
16	88.0	81.37	12			52	270.4	262.92	20		
17	93.0	86.38	12			53	275.4	267.97	20		
18	98.3	91.42	12			54	280.5	273.03	20		
19	103.3	96.45	12			55	285.5	278.08	20		
20	108.4	101.49	12			56	290.6	283.13	25		
21	113.4	106.52	12			57	296.0	288.18	25	25	25
22	118.0	111.55	12			58	300.7	293.23	25		
23	123.4	116.58	12			59	305.7	298.27	25		
24	128.3	121.62	12			60	310.8	303.32	25		
25	134.0	126.66	12			62	321.4	313.43	25		
26	139.0	131.70	16			64	331.5	323.53	25		
27	144.0	136.75	16			65	336.5	328.58	25		
28	148.7	141.78	16			66	341.6	333.63	25		
29	153.8	146.83	16			68	351.7	343.74	25		
30	158.8	151.87	16	20	20	70	361.8	353.84	25		
31	163.9	156.92	16			72	371.9	363.95	25		
32	168.9	161.95	16			75	387.1	379.09	25		
33	174.5	167.00	16			76	392.1	384.16	25	25	30
34	179.0	172.05	16			78	402.2	394.25	25		
35	184.1	177.10	16			80	412.3	404.35	25		
36	189.1	182.15	20			85	437.6	429.62	30		
37	194.2	187.20	20			90	462.8	454.88	30		
38	199.2	192.24	20	20	25	25	95.0	480.14	30	30	
39	204.2	197.29	20			100	513.4	505.39	30		
40	209.3	202.34	20			110	563.9	555.92	30		
41	214.8	207.39	20			114	584.1	576.13	30		
42	219.9	212.44	20			120	614.4	606.45	30		
43	224.9	217.49	20			125	639.7	631.51	30		

Pitch 5/8" x 3/8"

for roller chains in compliance with
DIN 8188-ISO/R 606 - ANSI B 29.1

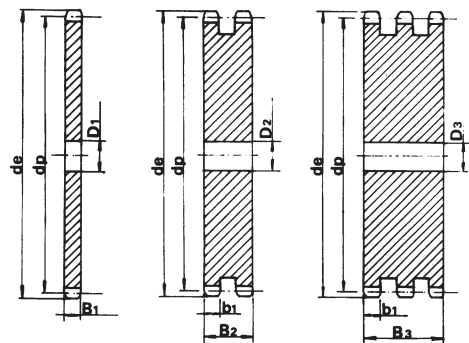
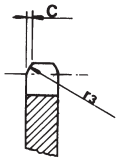

PLATEWHEEL

TOOTH RADIUS r ₃	17
RADIUS WIDTH C	2
PLATE TOOTH WIDTH B ₁	9
PLATE TOOTH WIDTH b ₁	8.8
PLATE TOOTH WIDTH B ₂	26.9
PLATE TOOTH WIDTH B ₃	45

CHAIN

PITCH	15.875
INNER WIDTH	9.52
ROLLER - Ø	10.16

S P R O C K E T S

Z	d _e	d _p	SINGLE			DOUBLE			TRIPLE		
			d _m	D ₁	A	d _m	D ₁	A	d _m	D ₁	A
			10	71.54	61.64	42	12	30	42	12	45
11	77.51	67.61	45	12	30	47	16	50			
12	83.49	73.61	45	12	30	53	16	50	53	20	70
13	89.49	79.59	60	14	35	59	16	50	59	20	70
14	95.50	85.61	60	14	35	65	16	50	65	20	70
15	101.52	91.63	60	14	35	71	16	50	71	20	70
16	107.54	97.65	75	16	35	77	20	50	77	20	70
17	113.56	103.67	75	16	35	83	20	50	83	20	70
18	119.59	109.71	75	16	35	89	20	50	89	20	70
19	125.63	115.75	80	16	35	95	20	50	95	20	70
20	131.67	121.78	80	16	35	100	20	50	100	20	70
21	137.71	127.82	80	16	35	100	20	50	100	20	70
22	143.75	133.86	90	20	40	100	20	50	100	20	70
23	149.79	139.90	90	20	40	110	20	50	110	20	70
24	155.84	145.94	90	20	40	110	20	50	110	20	70
25	161.88	152.00	90	20	40	120	20	50	120	20	70
26	167.93	158.04	90	20	40	120	20	50			
27	173.98	164.09	90	20	40	120	20	50			
28	180.03	170.13	95	20	40	120	20	50			
30	192.14	182.25	95	20	40	120	20	50			

ASA 60

Pitch 3/4" x 1/2"

for roller chains in compliance with
DIN 8188-ISO/R 606 - ANSI B 29.1

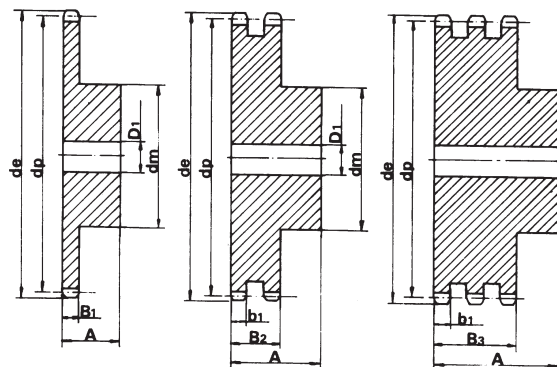
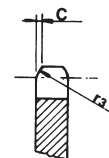

SPROCKET

mm

TOOTH RADIUS r ₃	20
RADIUS WIDTH C	2.4
SPROCKET TOOTH WIDTH B ₁	12.0
SPROCKET TOOTH WIDTH b ₁	11.8
SPROCKET TOOTH WIDTH B ₂	34.60
SPROCKET TOOTH WIDTH B ₃	57.4

CHAIN

mm

PITCH	19.05
INNER WIDTH	12.7
ROLLER - Ø	11.91

MATERIAL: C 45 UNI 7845

P L A T E W H E E L S

Z	d _e	d _p	S D T		
			D ₁	D ₂	D ₃
30	192.14	182.25			20
32	204.24	194.35		20	
38	240.58	230.69	20	25	25
40	252.69	242.80	20	25	
45	282.98	273.09	25	25	25
48	301.16	291.27	25		
57	355.70	345.81	25	25	30
76	470.87	460.98	30	30	30
95	586.06	576.17		30	

ASA 60

Pitch 3/4" x 1/2"

for roller chains in compliance with
DIN 8188-ISO/R 606 - ANSI B 29.1

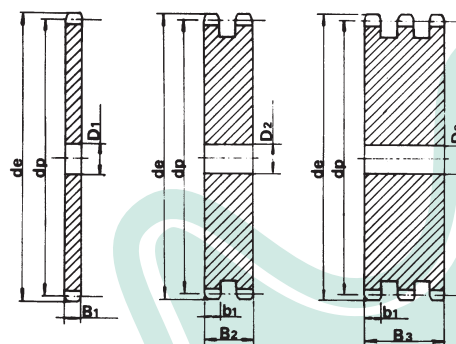
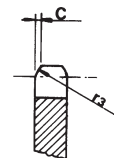

PLATEWHEEL

mm

TOOTH RADIUS r ₃	20
RADIUS WIDTH C	2.4
PLATE TOOTH WIDTH B ₁	12.0
PLATE TOOTH WIDTH b ₁	11.8
PLATE TOOTH WIDTH B ₂	34.6
PLATE TOOTH WIDTH B ₃	57.4

CHAIN

mm

PITCH	19.05
INNER WIDTH	12.7
ROLLER - Ø	11.91

S P R O C K E T S

ASA 80

Pitch 1" x 5/8"

for roller chains in compliance with
DIN 8188-ISO/R 606 - ANSI B 29.1

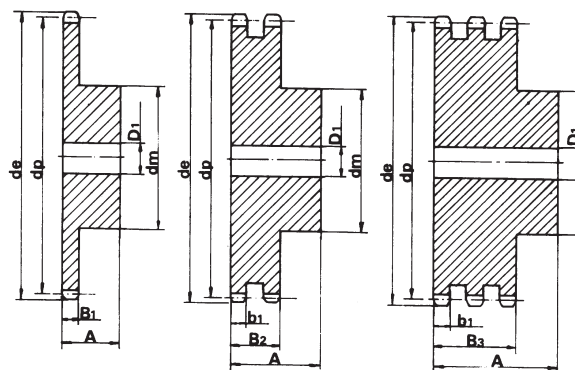
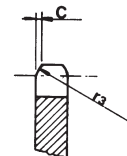

SPROCKET

TOOTH RADIUS r_3	27
RADIUS WIDTH C	3.2
SPROCKET TOOTH WIDTH B_1	15.0
SPROCKET TOOTH WIDTH b_1	14.7
SPROCKET TOOTH WIDTH B_2	44.0
SPROCKET TOOTH WIDTH B_3	73.3

CHAIN

PITCH	25.4
INNER WIDTH	15.88
ROLLER - \varnothing	15.88

MATERIAL: C 45 UNI 7845

Z	d_e	d_p	SINGLE			DOUBLE			TRIPLE		
			d_m	D_1	A	d_m	D_1	A	d_m	D_1	A
8	79.49	66.37	42	16	35						
9	87.38	74.27	50	16	35						
10	95.32	82.19	55	16	35						
11	103.28	90.14	61	16	40						
12	111.26	98.14	69	16	40	72	20	70	72	25	100
13	119.26	106.12	78	16	40	78	20	70	78	25	100
14	127.27	114.15	84	16	40	86	20	70	86	25	100
15	135.29	122.17	92	16	40	94	20	70	94	25	100
16	143.32	130.20	100	20	45	102	20	70	102	30	100
17	151.35	138.22	100	20	45	110	20	70	110	30	100
18	159.39	146.28	100	20	45	118	20	70	118	30	100
19	167.44	154.33	100	20	45	126	20	70	126	30	100
20	175.49	162.38	100	20	45	130	20	70	130	30	100
21	183.54	170.43	110	20	50	130	25	70			
22	191.60	178.48	110	20	50						
23	199.66	186.53	110	20	50						
24	207.72	194.59	110	20	50						
25	215.78	202.66	110	20	50						
26	223.84	210.72	120	20	50						
27	231.91	218.79	120	20	50						
28	239.98	226.85	120	20	50						
29	248.05	234.92	120	20	50						
30	256.12	243.00	120	20	50						

P L A T E W H E E L S

ASA 80

Pitch 1" x 5/8"

for roller chains in compliance with
DIN 8188-ISO/R 606 - ANSI B 29.1

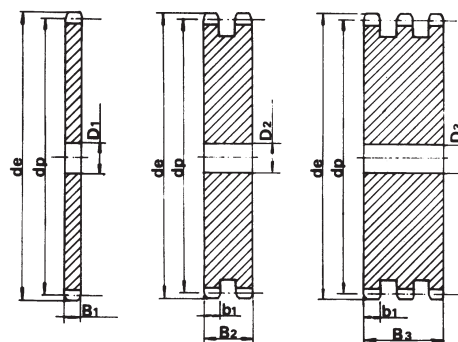
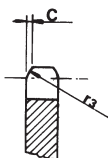

PLATEWHEEL

TOOTH RADIUS r_3	27
RADIUS WIDTH C	3.2
PLATE TOOTH WIDTH B_1	15.0
PLATE TOOTH WIDTH b_1	14.7
PLATE TOOTH WIDTH B_2	44.0
PLATE TOOTH WIDTH B_3	73.3

CHAIN

PITCH	25.4
INNER WIDTH	15.88
ROLLER - \varnothing	15.88

Z	d_e	d_p	S D T		
			D_1	D_2	D_3
10	95.32	82.19	15		
11	103.28	90.14	15		
12	111.26	98.14	15		
13	119.26	106.12	15		
14	127.27	114.15	15		
15	135.29	122.17	15		
16	143.32	130.20	19		
17	151.35	138.22	19		
18	159.39	146.28	19		
19	167.44	154.33	19		
20	175.49	162.38	19		
21	183.54	170.43	20		
22	191.60	178.48	20		
23	199.66	186.53	20		
24	207.72	194.59	20		
25	215.78	202.66	20	25	30
26	223.84	210.72	20		
27	231.91	218.79	20		
28	239.98	226.85	20		
30	256.12	243.00	20	25	30
32	272.26	259.13	25		
35	296.48	283.36	25		
38	320.70	307.59	25	25	30
45	377.24	364.12	25	25	30
50	417.64	404.52	25		
57	474.20	461.08	25	25	40
76	627.80	614.64	25	25	40

Z	d _e	d _p	SINGLE			DOUBLE		
			d _m	D ₁	A	d _m	D ₁	A
8	98.1	82.96	53	20	40			
9	108.0	92.84	63	20	40			
10	117.9	102.74	70	20	40			
11	127.8	112.68	77	20	45			
12	137.8	122.68	88	20	45			
13	147.8	132.65	98	20	45	90	20	80
14	157.8	142.68	108	20	45	100	20	80
15	167.9	152.72	118	20	45	110	20	80
16	177.9	162.75	120	25	50	120	20	80
17	187.9	172.78	120	25	50	120	25	80
18	198.0	182.85	120	25	50			
19	208.1	192.91	120	25	50			
20	218.1	202.98	120	25	50			
21	228.2	213.04	140	25	55			
22	238.3	223.11	140	25	55			
23	248.3	233.17	140	25	55			
24	258.4	243.23	140	25	55			
25	268.5	253.33	140	25	55			

Pitch 1" 1/4 x 3/4"

for roller chains in compliance with
DIN 8188-ISO/R 606 - ANSI B 29.1

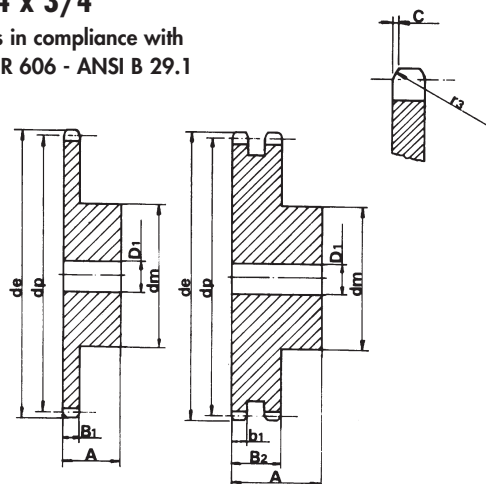

SPROCKET

	mm
TOOTH RADIUS r ₃	33.5
RADIUS WIDTH C	4
SPROCKET TOOTH WIDTH B ₁	18.0
SPROCKET TOOTH WIDTH b ₁	17.7
SPROCKET TOOTH WIDTH B ₂	53.5
SPROCKET TOOTH WIDTH B ₃	89.2

CHAIN

	mm
PITCH	31.75
INNER WIDTH	19.05
ROLLER - Ø	19.05

MATERIAL: C 45 UNI 7845

P L A T E W H E E L S

Z	d _e	d _p	S D T		
			D ₁	D ₂	D ₃
8	98.1	82.96	16		
9	108.0	92.84	16		
10	117.9	102.74	16		
11	127.8	112.68	16		
12	137.8	122.68	20		
13	147.8	132.65	20		
14	157.8	142.68	20		
15	167.9	152.72	20		
16	177.9	162.75	25		
17	187.9	172.78	25		
18	198.0	182.85	25		
19	208.1	192.91	25		
20	218.1	202.98	25	25	
21	228.2	213.04	25		
22	238.3	223.11	25		
23	248.3	233.17	25		
24	258.4	243.23	25		
25	268.5	253.33	25	25	
26	278.6	263.40	25		
27	288.6	273.40	25		
28	298.7	283.56	25		
29	308.8	293.65	25		
30	318.9	303.75	25	25	
31	329.0	313.85	25		
32	339.1	323.91	25		
33	349.2	334.01	25		
34	359.3	344.10	25		
35	369.4	354.20	25		
36	379.5	364.30	25		
37	389.5	374.39	25		
38	399.6	384.49	25	30	
39	409.7	394.59	25		
40	419.8	404.68	25		
45	470.3	455.17	30	30	
57	591.5	576.36	30	30	

Pitch 1" 1/4 x 3/4"

for roller chains in compliance with
DIN 8188-ISO/R 606 - ANSI B 29.1

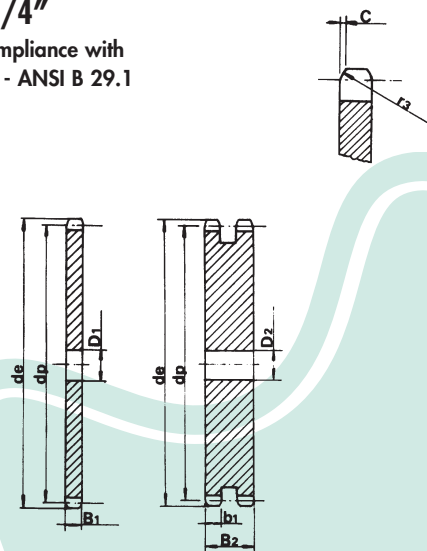

PLATEWHEEL

	mm
TOOTH RADIUS r ₃	33.5
RADIUS WIDTH C	4
PLATE TOOTH WIDTH B ₁	18.0
PLATE TOOTH WIDTH b ₁	17.7
PLATE TOOTH WIDTH B ₂	53.5
PLATE TOOTH WIDTH B ₃	89.2

CHAIN

	mm
PITCH	31.75
INNER WIDTH	19.05
ROLLER - Ø	19.05

SPROCKETS

Z	d _e	d _p	SINGLE			DOUBLE		
			d _m	D ₁	A	d _m	D ₁	A
8	119.04	99.55	58	20	45			
9	130.88	111.4	70	20	45			
10	142.77	123.29	80	20	45			
11	154.71	135.21	90	25	50			
12	166.69	147.22	102	25	50	102	25	100
13	178.68	159.18	114	25	50	114	25	100
14	190.7	171.22	128	25	50	128	25	100
15	202.73	183.26	140	25	50	140	25	100

PLATEWHEELS

Z	d _e	d _p	S	D	T
			D ₁	D ₂	
16	214.77	195.29		25	
17	226.83	207.35		25	25
18	238.89	219.41		25	25
20	263.03	243.55		25	25
22	287.2	267.72		25	
25	323.47	303.99		25	25
30	383.97	364.49		30	30
32	408.19	388.71		30	
38	480.85	461.37		30	30
45	565.67	546.19		30	40
57	711.1	691.62			40

Pitch 1" 1/2 x 1"

for roller chains in compliance with
DIN 8188-ISO/R 606 - ANSI B 29.1

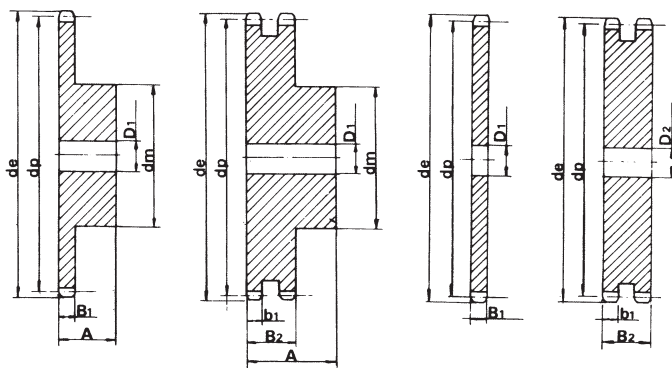
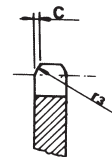

SPROCKET

	mm
TOOTH RADIUS r ₃	40.5
RADIUS WIDTH C	4.8
SPROCKET TOOTH WIDTH B ₁	24.1
SPROCKET TOOTH WIDTH b ₁	23.6
SPROCKET TOOTH WIDTH B ₂	69.0

CHAIN

	mm
PITCH	38.1
INNER WIDTH	25.4
ROLLER - Ø	22.22

MATERIAL: C 45 SPROCKETS UNI 7845

All the deleted tooth profiles are available till sold out.
At the Customer's request, we are able to produce tooth profiles and pitches in accordance with ASA profiles not shown in this Catalogue on a final cost basis.

DOUBLE / SINGLE PLATEWHEELS

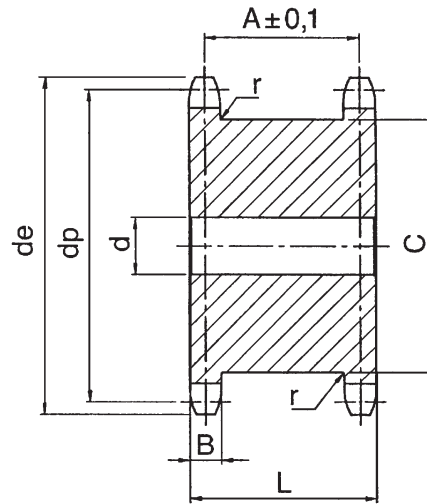

Material / C45 UNI 7845

TYPE	Z	OUTSIDE De	PITCH Dp	d	A	B h14	C max	L	r
3/8"x7/32" R. 6.35 06 B-1	13	43.45	39.80	10	20.3	5.3	28	25.5	0.4
	15	49.46	45.81	10	20.3	5.3	34	25.5	0.4
	17	55.49	51.84	12	20.3	5.3	40	25.5	0.4
	18	58.30	54.85	12	20.3	5.3	43	25.5	0.4
	19	61.52	57.87	12	20.3	5.3	46	25.5	0.4
	20	64.30	60.89	12	20.3	5.3	49	25.5	0.4
	21	67.56	63.91	15	20.3	5.3	52	25.5	0.4
	23	73.60	69.95	15	20.3	5.3	59	25.5	0.4
25	79.65	76.00	15	20.3	5.3	65	25.5	0.4	
1/2"x5/16" R. 8.51 08 B-1	13	57.56	53.07	12	24.8	7.2	37	32	0.6
	15	65.57	61.08	12	24.8	7.2	45	32	0.6
	17	73.61	69.12	12	24.8	7.2	53	32	0.6
	18	78.00	73.14	12	24.8	7.2	57	32	0.6
	19	81.65	77.16	12	24.8	7.2	62	32	0.6
	20	86.00	81.19	12	24.8	7.2	65	32	0.6
	21	89.70	85.21	15	24.8	7.2	70	32	0.6
	23	97.76	93.27	15	24.8	7.2	78	32	0.6
25	105.82	101.33	15	24.8	7.2	86	32	0.6	
5/8"x3/8" R. 10.16 10 B-1	13	73.17	66.33	15	27.9	9.1	48	37	0.6
	15	83.19	76.35	15	27.9	9.1	58	37	0.6
	17	93.23	86.39	15	27.9	9.1	68	37	0.6
	18	98.30	91.42	15	27.9	9.1	72	37	0.6
	19	103.29	96.45	15	27.9	9.1	79	37	0.6
	20	108.40	101.49	19	27.9	9.1	82	37	0.6
	21	113.35	106.51	19	27.9	9.1	89	37	0.6
	23	123.43	116.59	19	27.9	9.1	99	37	0.6
25	133.50	126.66	19	27.9	9.1	109	37	0.6	
3/4"x7/16" R. 12.07 12 B-1	13	87.13	76.90	20	33.9	11.1	59	45	0.6
	15	99.16	91.63	20	33.9	11.1	71	45	0.6
	17	111.20	103.67	20	33.9	11.1	83	45	0.6
	18	118.00	109.71	20	33.9	11.1	88	45	0.6
	19	123.27	115.74	20	33.9	11.1	95	45	0.6
	20	129.70	121.78	20	33.9	11.1	101	45	0.6
	21	135.35	127.82	20	33.9	11.1	107	45	0.6
	23	147.43	139.90	20	33.9	11.1	119	45	0.6
25	159.52	151.99	24	33.9	11.1	131	45	0.6	
1"x17.02 R. 15.88 16 B-1	13	117.26	106.14	24	47.8	16.2	78	64	0.8
	15	133.29	122.17	24	47.8	16.2	95	64	0.8
	17	149.35	138.23	24	47.8	16.2	111	64	0.8
	18	157.00	146.28	24	47.8	16.2	119	64	0.8
	19	165.44	154.32	24	47.8	16.2	127	64	0.8
	20	173.00	162.38	24	47.8	16.2	135	64	0.8
	21	181.54	170.42	24	47.8	16.2	143	64	0.8
	23	197.66	186.54	24	47.8	16.2	160	64	0.8
25	213.78	202.66	24	47.8	16.2	176	64	0.8	

SINGLE SPROCKETS WITH INDUCTION HARDENED TEETH WITH BORE + KEYWAY + SETSCREW HOLES

3/8" x 7/32" 06B-1

for roller chains in compliance with DIN 8187 ISO/R 606

z	d _e	d _p	d _m	A	D ₁	z	d _e	d _p	d _m	A	D ₁	z	d _e	d _p	d _m	A	D ₁
13	43.5	39.80	28	25	12 14 15 16 18	18	58.3	54.85	43	28	14 15 16 18 19 20 22 24	23	73.7	69.95	52	28	15 16 18 19 20 22 24 25
14	46.5	42.80	31	25	12 14 15 16 18	19	61.6	57.87	45	28	15 16 18 19 20 22 24	24	76.7	72.97	54	28	18 19 20 22 24 25
15	49.5	45.81	34	25	14 15 16 18 19 20 22 24	20	64.3	60.89	46	28	15 16 18 19 20 22 24	25	79.7	76.00	57	28	18 20 22 24 25
16	52.3	48.82	37	28	14 15 16 18 19 20 22 24	21	67.6	63.91	48	28	15 16 18 19 20 22 24	27	85.7	82.05	60	28	20 22 24 25
17	55.5	51.83	40	28	14 15 16 18 19 20 22 24							30	94.8	91.12	60	30	20 22 24 25

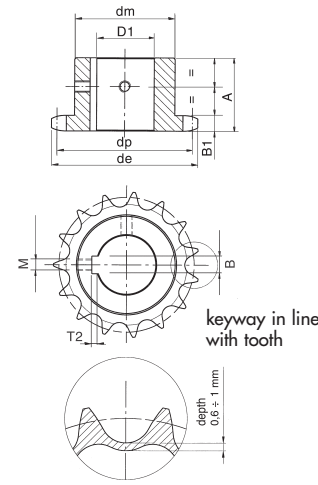

Induction hardened teeth HRC 45-53

SPROCKET		mm
SPROCKET TOOTH WIDTH B_1		5.3
CHAIN		mm
PITCH		9.525
INNER WIDTH		5.72
ROLLER - \emptyset		6.35

MATERIAL: C 45 UNI 7845

z	d _e	d _p	d _m	A	D ₁	z	d _e	d _p	d _m	A	D ₁	z	d _e	d _p	d _m	A	D ₁
12	53.9	49.07	33	28	12 14 15 16 18 19 20	17	74	69.11	52	28	15 16 18 19 20 22 24 25 28 30	23	98.1	93.27	70	28	20 22 24 25 28 30 32 35 38
13	57.9	53.06	37	28	12 14 15 16 18 19 20 22 24	18	77.8	73.14	56	28	16 18 19 20 22 24 25 28 30 32 35	24	102.1	97.29	70	28	20 22 24 25 28 30 32 35 38
14	61.6	57.07	41	28	14 15 16 18 19 20 22 24 25	19	82	77.16	60	28	19 20 22 24 25 28 30 32 35	25	105.8	101.33	70	28	20 22 24 25 28 30 32 35 38
15	65.9	61.09	45	28	14 15 16 18 19 20 22 24 25	20	85.8	81.19	64	28	19 20 22 24 25 28 30 32 35	27	114	109.4	70	30	22 25 28 30 32 35 38
16	69.5	65.1	50	28	15 16 18 19 20 22 24 25	21	90.1	85.22	68	28	19 20 22 24 25 28 30 32 35	30	126.3	121.5	80	30	25 28 30 32 35 38

1/2" x 5/16" 08B-1

for roller chains in compliance with DIN 8187 ISO/R 606

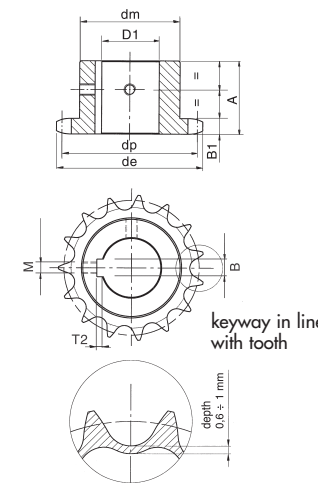

Induction hardened teeth HRC 45-53

SPROCKET		mm
SPROCKET TOOTH WIDTH B_1		7.2
CHAIN		mm
PITCH		12.7
INNER WIDTH		7.75
ROLLER - \emptyset		8.51

MATERIAL: C 45 UNI 7845

SINGLE SPROCKETS WITH INDUCTION HARDENED TEETH WITH BORE + KEYWAY + SETSCREW HOLES

z	d _e	d _p	d _m	A	D ₁	z	d _e	d _p	d _m	A	D ₁	z	d _e	d _p	d _m	A	D ₁																																																																																	
13	73.2	66.32	47	30	16	18	98.3	91.42	70	30	20	23	123.4	116.58	80	30	20	20																																																																																
					19														22	22	22	24	25	28	30	32	35	38	40																																																																					
					14														78.2	71.34	52	30	19	103.3	96.45	70	30	20	24	128.5	121.62	80	30	20	22																																																															
					19																															22	24	25	28	30	32	35	38	40																																																						
					15																															83.2	76.36	57	30	20	108.4	101.49	75	30	20	25	133.5	126.66	80	30	22	24	25																																													
					19																																																	22	24	25	28	30	32	35	38	40																																				
					16																																																	88	81.37	60	30	22	113.4	106.52	75	30	20	28	138.5	131.62	80	30	22	24	25																											
					19																																																																			22	24	25	28	30	32	35	38	40																		
					17																																																																			93.2	86.39	60	30	22	118.4	111.49	75	30	20	28	143.5	136.62	80	30	22	24	25									
					19																																																																																					22	24	25	28	30	32	35	38	40

5/8" x 3/8" 10B-1

for roller chains in compliance with DIN 8187 ISO/R 606

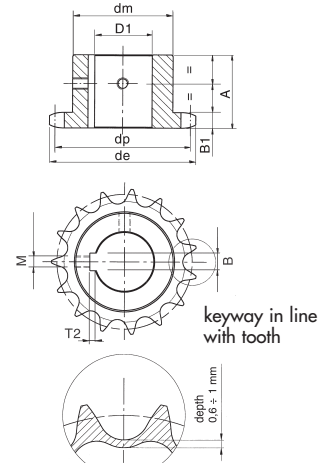

Induction hardened teeth HRC 45±53

SPROCKET ————— **mm**

SPROCKET TOOTH WIDTH B₁ **9.1**

CHAIN ————— **mm**

PITCH **15.875**
 INNER WIDTH **9.65**
 ROLLER – Ø **10.16**

MATERIAL: C 45 UNI 7845

z	d _e	d _p	d _m	A	D ₁	z	d _e	d _p	d _m	A	D ₁	z	d _e	d _p	d _m	A	D ₁																																																																														
12	81.8	73.6	52	35	20	17	111.2	103.67	80	35	22	23	147.4	139.90	90	40	28	30																																																																													
					22														22	24	25	28	30	32	35	38	40																																																																				
					13														87.1	79.60	58	35	20	118.0	109.71	80	35	22	24	154.1	145.94	90	40	28	30																																																												
					22																															22	24	25	28	30	32	35	38	40																																																			
					14																															93.8	85.61	64	35	20	123.3	115.75	80	35	25	25	159.5	152.00	90	40	28	30																																											
					22																																																22	24	25	28	30	32	35	38	40																																		
					15																																																99.2	91.63	70	35	22	129.7	121.78	80	35	25	28	164.5	157.00	90	40	28	30																										
					22																																																																	22	24	25	28	30	32	35	38	40																	
					16																																																																	105.5	97.65	75	35	20	135.4	127.82	90	40	28	28	169.5	162.00	90	40	28	30									
					22																																																																																		22	24	25	28	30	32	35	38	40

3/4" x 7/16" 12B-1

for roller chains in compliance with DIN 8187 ISO/R 606

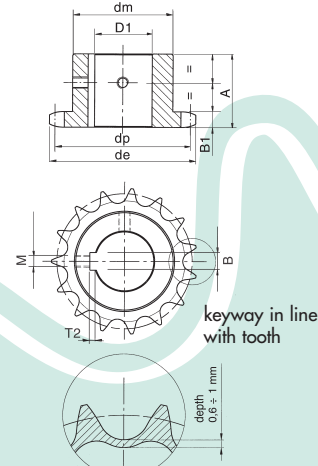

Induction hardened teeth HRC 45±53

SPROCKET ————— **mm**

SPROCKET TOOTH WIDTH B₁ **11.1**

CHAIN ————— **mm**

PITCH **19.05**
 INNER WIDTH **11.68**
 ROLLER – Ø **12.07**

MATERIAL: C 45 UNI 7845

SINGLE SPROCKETS WITH INDUCTION HARDENED TEETH WITH BORE + KEYWAY + SETSCREW HOLES

z	d _e	d _p	d _m	A	D ₁	z	d _e	d _p	d _m	A	D ₁	z	d _e	d _p	d _m	A	D ₁
12	109.71	98.14	69	40	25	16	141.0	130.20	100	45	30	20	173.2	162.38	100	45	30
					28						32						32
					30						35						35
					32						38						38
					35						40						40
					38						42						42
					40						45						45
					42						48						48
					45						50						50
13	117.2	106.14	78	40	25	17	149.4	138.22	100	45	30	21	181.6	170.43	110	50	30
					28						32						32
					30						35						35
					32						38						38
					35						40						40
					38						42						42
					40						45						45
					42						48						48
					45						50						50
14	125.7	114.15	84	40	25	18	157.0	146.28	100	45	30	23	198.1	186.1	110	50	30
					28						32						32
					30						35						35
					32						38						38
					35						40						40
					38						42						42
					40						45						45
					42						48						48
					45						50						50
15	133.3	122.17	92	40	28	19	165.5	154.33	100	45	30	25	214.2	202.66	110	50	30
					30						32						32
					32						35						35
					35						38						38
					38						40						40
					40						42						42
					42						45						45
					45						48						48
					48						50						50

1" x 17.02 16B-1

for roller chains in compliance with DIN 8187 ISO/R 606

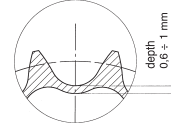
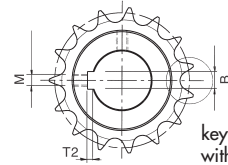
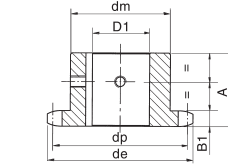

Induction hardened teeth HRC 45-53

SPROCKET mm

SPROCKET TOOTH WIDTH B₁ 16.2

CHAIN mm

PITCH 25.4
 INNER WIDTH 17.02
 ROLLER - Ø 15.88

MATERIAL: C 45 UNI 7845

KEYWAY TO DIN 6885 - JS9

D ₁ Bore	B Keyway Width	T ₂ Keyway Depth	M Screws
Ø 12 H7 ^{+0.018} ₋₀	4 H9 ^{+0.030} ₋₀	1,8 ^{+0.10} ₋₀	M4
Ø 14 H7 ^{+0.018} ₋₀	5 H9 ^{+0.030} ₋₀	2,3 ^{+0.10} ₋₀	M4
Ø 15 H7 ^{+0.018} ₋₀	5 H9 ^{+0.030} ₋₀	2,3 ^{+0.10} ₋₀	M4
Ø 16 H7 ^{+0.018} ₋₀	5 H9 ^{+0.030} ₋₀	2,3 ^{+0.10} ₋₀	M4
Ø 18 H7 ^{+0.018} ₋₀	6 H9 ^{+0.030} ₋₀	2,8 ^{+0.10} ₋₀	M5
Ø 19 H7 ^{+0.021} ₋₀	6 H9 ^{+0.030} ₋₀	2,8 ^{+0.10} ₋₀	M5
Ø 20 H7 ^{+0.021} ₋₀	6 H9 ^{+0.030} ₋₀	2,8 ^{+0.10} ₋₀	M5
Ø 22 H7 ^{+0.021} ₋₀	6 H9 ^{+0.030} ₋₀	2,8 ^{+0.10} ₋₀	M5
Ø 24 H7 ^{+0.021} ₋₀	8 H9 ^{+0.036} ₋₀	3,3 ^{+0.20} ₋₀	M6
Ø 25 H7 ^{+0.021} ₋₀	8 H9 ^{+0.036} ₋₀	3,3 ^{+0.20} ₋₀	M6
Ø 28 H7 ^{+0.021} ₋₀	8 H9 ^{+0.036} ₋₀	3,3 ^{+0.20} ₋₀	M6
Ø 30 H7 ^{+0.021} ₋₀	8 H9 ^{+0.036} ₋₀	3,3 ^{+0.20} ₋₀	M6
Ø 32 H7 ^{+0.025} ₋₀	10 H9 ^{+0.036} ₋₀	3,3 ^{+0.20} ₋₀	M8
Ø 35 H7 ^{+0.025} ₋₀	10 H9 ^{+0.036} ₋₀	3,3 ^{+0.20} ₋₀	M8
Ø 38 H7 ^{+0.025} ₋₀	10 H9 ^{+0.036} ₋₀	3,3 ^{+0.20} ₋₀	M8
Ø 40 H7 ^{+0.025} ₋₀	12 H9 ^{+0.043} ₋₀	3,3 ^{+0.20} ₋₀	M10
Ø 42 H7 ^{+0.025} ₋₀	12 H9 ^{+0.043} ₋₀	3,3 ^{+0.20} ₋₀	M10
Ø 45 H7 ^{+0.025} ₋₀	14 H9 ^{+0.043} ₋₀	3,8 ^{+0.20} ₋₀	M12
Ø 48 H7 ^{+0.025} ₋₀	14 H9 ^{+0.043} ₋₀	3,8 ^{+0.20} ₋₀	M12
Ø 50 H7 ^{+0.025} ₋₀	14 H9 ^{+0.043} ₋₀	3,8 ^{+0.20} ₋₀	M12

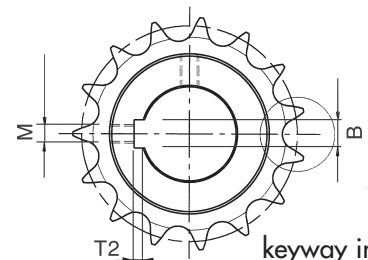
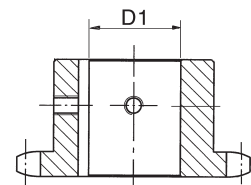

Taper - Lock® SPROCKETS

PITCH

SIMPLE						
Pitch code	Z	bush	Type of Execution	Hub Dm	A	
081-13	13	1610	1	78	25	
081-14	14	1610	1	78	25	
081-15 •	15	1610	1	78	25	
081-16	16	2012	1	90	32	
081-17 •	17	2012	1	90	32	
081-18	18	2517	1	108	45	
081-19 •	19	2517	1	108	45	
081-20	20	2517	1	108	45	
081-21 •	21	2517	1	108	45	
081-22	22	2517	1	108	45	
081-23 •	23	2517	1	108	45	
081-24	24	2517	1	108	45	
081-25 •	25	2517	1	108	45	
081-26	26	2517	1	108	45	
081-27 •	27	2517	1	108	45	
081-28	28	2517	1	108	45	
081-30 •	30	3020	1	159	51	
081-38	38	3020	6	159	51	
081-45	45	3020	6	159	51	
081-57*	57	3020	6	159	51	
081-76*	76	3020	6	159	51	
081-95*	95	3020	6	159	51	
081-114*	114	3030	6	150	76	
101-15 •	15	2517	1	108	45	
101-17 •	17	2517	1	108	45	
101-19 •	19	2517	1	108	45	
101-21 •	21	2517	1	108	45	
101-23 •	23	2517	1	108	45	
101-25 •	25	2517	1	108	45	
101-30	30	3020	1	159	51	
101-38	38	3020	1	159	55	

1"
25.40 mm

1" 1/4
31.75 mm

PITCH

DOUBLE						
Pitch code	Z	bush	Type of Execution	Hub Dm	A	
082-15	15	2012	3		47.7	
082-16	16	2517	3		47.7	
082-17	17	2517	3		47.7	
082-18	18	2517	3		47.7	
082-19	19	2517	3		47.7	
082-20	20	2517	3		47.7	
082-21	21	3020	2	143	51	
082-22	22	3020	2	150	51	
082-23	23	3020	2	159	51	
082-24	24	3020	2	166	51	
082-25	25	3020	2	175	51	
082-26	26	3020	2	175	51	
082-27	27	3020	2	175	51	
082-28	28	3020	2	175	51	
082-30	30	3020	2	175	51	
082-38*	38	3020	7	146	51	
082-45*	45	3020	7	146	51	
082-57*	57	3525	7	198	65	
082-76*	76	3525	7	198	65	
082-95*	95	3525	7	216	65	
082-114*	114	4040	7	216	102	

1"
25.40 mm

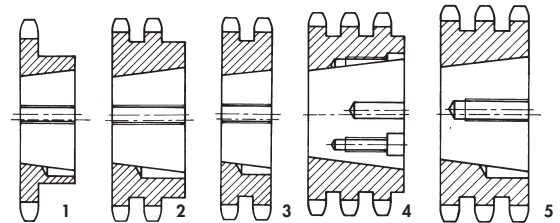

PITCH

TRIPLE						
Pitch code	Z	bush	Type of Execution	Hub Dm	A	
063-15	15	1615	5		49.8	
063-17	17	2012	5		49.8	
063-19	19	2012	5		49.8	
063-21	21	2517	5		49.8	
063-23	23	2517	5		49.8	
063-25	25	2517	5		49.8	
063-27	27	3020	5		51.0	
063-30	30	3020	5		51.0	
063-38	38	3020	5		51.0	
063-45	45	3020	5		51.0	
063-57*	57	3020	8	159	51.0	
063-76*	76	3020	8	159	51.0	
063-95*	95	3030	8	165	76.0	
063-114*	114	3030	8	165	76.0	
083-17	17	2517	5		79.6	
083-19	19	3020	5		79.6	
083-21	21	3020	5		79.6	
083-23	23	3525	5		79.6	
083-25	25	3525	5		79.6	
083-27	27	3525	5		79.6	
083-30	30	3525	5		79.6	
083-38	38	3525	5		79.6	
083-45*	45	4030	9	216	79.6	
083-57*	57	4030	9	216	79.6	
083-76*	76	4030	9	216	79.6	
083-95*	95	4030	9	240	79.6	
083-114*	114	4545	8	240	115	

3/4"
19.05 mm

1"
25.40 mm

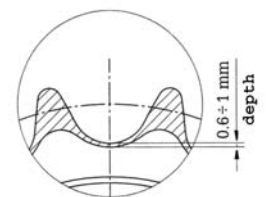
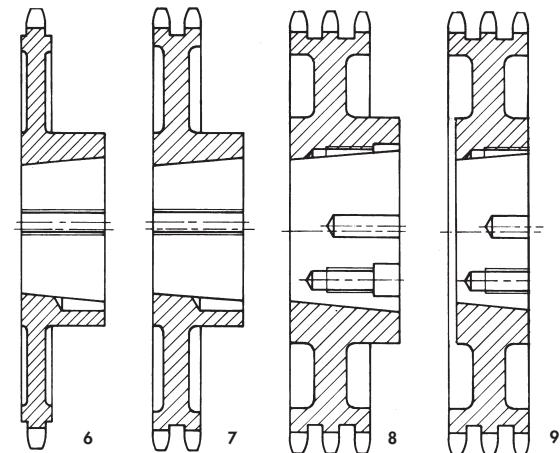

Induction hardened teeth HRC 45±3

• ALSO AVAILABLE WITH HARDENED TEETH

MATERIAL: STEEL = C 45 UNI 7845 * CAST IRON = G 20 - UNI 5007

CAST IRON SPROCKETS: G 20 UNI 5007

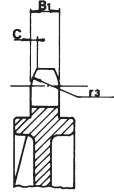
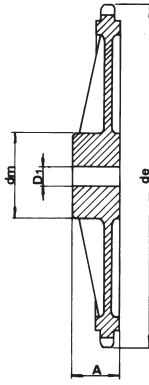
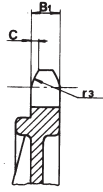
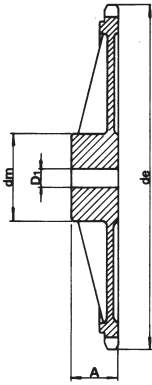

3/8" x 7/32" for roller chains in compliance with DIN 8187 ISO/R 606

z	d _e	d _p	SINGLE			DOUBLE			TRIPLE		
			d _m	D ₁	A	d _m	D ₁	A	d _m	D ₁	A
38	119.5	115.35	70	19	32	80	19	40	90	23	56
45	140.7	136.55	70	19	32	80	19	40	90	23	56
57	176.9	172.91	70	19	32	80	19	40	90	23	56
76	234.9	230.49	70	19	32	80	19	40	100	23	56
*95	292.5	288.08	80	19	40	90	19	45	100	23	56
*114	349.6	345.68	80	19	40	90	19	45	100	23	56
*150	459.2	454.82	90	23	45	100	23	50	125	23	60

SPROCKET	mm
TOOTH RADIUS r ₃	10
RADIUS WIDTH C	1
SPROCKET TOOTH WIDTH B ₁	5.3
SPROCKET TOOTH WIDTH b ₁	5.2
SPROCKET TOOTH WIDTH B ₂	15.4
SPROCKET TOOTH WIDTH B ₃	25.6

CHAIN	mm
PITCH	9.525
INNER WIDTH	5.72
ROLLER - Ø	6.35

1/2" x 5/16" for roller chains in compliance with DIN 8187 ISO/R 606

z	d _e	d _p	SINGLE			DOUBLE			TRIPLE		
			d _m	D ₁	A	d _m	D ₁	A	d _m	D ₁	A
38	158.6	153.80	70	19	40	90	23	50	100	23	60
45	188	182.07	70	19	40	90	23	50	100	23	60
57	236.4	230.54	70	19	40	90	23	50	100	23	60
76	313.3	307.33	80	23	40	100	23	56	100	23	60
95	390.1	384.11	80	23	45	100	23	56	120	23	67
114	466.9	460.90	90	23	45	100	23	63	120	23	67

SPROCKET	mm
TOOTH RADIUS r ₃	13
RADIUS WIDTH C	1.3
SPROCKET TOOTH WIDTH B ₁	7.2
SPROCKET TOOTH WIDTH b ₁	7
SPROCKET TOOTH WIDTH B ₂	21
SPROCKET TOOTH WIDTH B ₃	34.9

CHAIN	mm
PITCH	12.7
INNER WIDTH	7.75
ROLLER - Ø	8.51

5/8" x 3/8" for roller chains in compliance with DIN 8187 ISO/R 606

z	d _e	d _p	SINGLE			DOUBLE			TRIPLE		
			d _m	D ₁	A	d _m	D ₁	A	d _m	D ₁	A
38	199.2	192.24	80	19	40	100	29	50	100	31	60
45	235	227.58	80	19	40	100	29	50	100	31	60
57	296	288.18	90	23	45	100	29	56	100	31	63
*76	392.1	384.16	90	23	50	100	29	63	110	34	67
*95	488.5	480.14	100	23	56	110	29	63	125	34	70
*114	584.1	576.13	100	23	56	125	29	70	125	34	80

SPROCKET	mm
TOOTH RADIUS r ₃	16
RADIUS WIDTH C	1.6
SPROCKET TOOTH WIDTH B ₁	9.1
SPROCKET TOOTH WIDTH b ₁	9
SPROCKET TOOTH WIDTH B ₂	25.5
SPROCKET TOOTH WIDTH B ₃	42.1

CHAIN	mm
PITCH	15.875
INNER WIDTH	9.65
ROLLER - Ø	10.16

3/4" x 7/16" for roller chains in compliance with DIN 8187 ISO/R 606

z	d _e	d _p	SINGLE			DOUBLE			TRIPLE		
			d _m	D ₁	A	d _m	D ₁	A	d _m	D ₁	A
38	239	230.69	100	23	56	110	29	63	140	31	70
45	282.5	273.1	100	23	56	110	29	63	140	31	70
57	354	345.81	100	29	56	120	29	63	140	39	70
76	469.9	460.99	100	29	56	135	29	63	160	39	75
*95	585.1	576.17	100	29	65	135	29	70	170	39	82
*114	700.6	691.36	100	29	65	135	44	70	170	49	82

SPROCKET	mm
TOOTH RADIUS r ₃	19
RADIUS WIDTH C	2
SPROCKET TOOTH WIDTH B ₁	11.1
SPROCKET TOOTH WIDTH b ₁	10.8
SPROCKET TOOTH WIDTH B ₂	30.3
SPROCKET TOOTH WIDTH B ₃	49.8

CHAIN	mm
PITCH	19.05
INNER WIDTH	11.68
ROLLER - Ø	12.07

CAST IRON SPROCKETS: G 20 UNI 5007

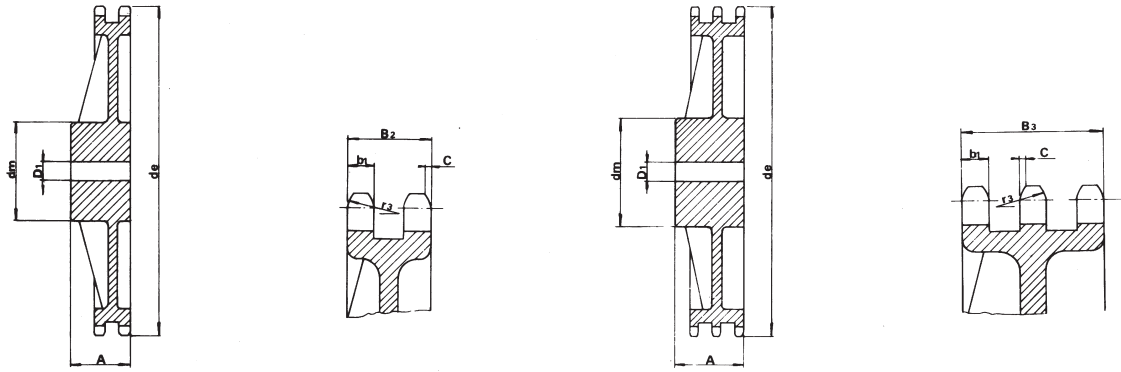

1" x 17.02 mm for roller chains in compliance with DIN 8187 ISO/R 606

z	d _e	d _p	SINGLE			DOUBLE			TRIPLE		
			d _m	D ₁	A	d _m	D ₁	A	d _m	D ₁	A
30	254.0	243.00	110	29	65	125	39	75	145	39	90
38	320.0	307.59	110	29	65	140	39	75	160	44	100
45	377.0	364.13	125	29	70	148	39	75	160	44	100
57	474.0	461.08	125	34	70	160	39	90	165	44	100
76	627.0	614.65	140	34	80	175	39	95	200	44	110
95	781.0	768.22	140	39	80	175	44	95	200	49	110
*114	933.0	921.81	150	39	80	175	44	95	200	49	115

SPROCKET	mm
TOOTH RADIUS r ₃	26
RADIUS WIDTH C	2.5
SPROCKET TOOTH WIDTH B ₁	16.2
SPROCKET TOOTH WIDTH b ₁	15.8
SPROCKET TOOTH WIDTH B ₂	47.7
SPROCKET TOOTH WIDTH B ₃	79.6

CHAIN	mm
PITCH	25.4
INNER WIDTH	17.02
ROLLER - ø	15.88

1" 1/4 x 3/4" for roller chains in compliance with DIN 8187 ISO/R 606

z	d _e	d _p	SINGLE			DOUBLE			TRIPLE		
			d _m	D ₁	A	d _m	D ₁	A	d _m	D ₁	A
30	318.9	303.75	115	34	70	130	39	80			
38	399.6	384.49	125	34	70	140	44	90	170	55	110
45	470.3	455.17	125	34	70	140	44	90			
57	591.5	576.36	135	39	80	160	49	100	180	62	125
76	783.5	768.32	140	49	90	180	55	100			

SPROCKET	mm
TOOTH RADIUS r ₃	32
RADIUS WIDTH C	3.5
SPROCKET TOOTH WIDTH B ₁	18.5
SPROCKET TOOTH WIDTH b ₁	18.2
SPROCKET TOOTH WIDTH B ₂	54.6
SPROCKET TOOTH WIDTH B ₃	91

CHAIN	mm
PITCH	31.75
INNER WIDTH	19.56
ROLLER - ø	19.05

1" 1/2 x 1" for roller chains in compliance with DIN 8187 ISO/R 606

z	d _e	d _p	SINGLE			DOUBLE			TRIPLE		
			d _m	D ₁	A	d _m	D ₁	A	d _m	D ₁	A
30	379.5	364.5	130	39	85						
38	476.2	461.39	140	44	90	180	44	100	200	62	150
45	581.2	546.2	140	44	90						
57	706.5	691.63	160	44	100	200	54	110	200	62	150
76	936.9	921.98	170	44	100	220	54	120	250	69	150

SPROCKET	mm
TOOTH RADIUS r ₃	38
RADIUS WIDTH C	4
SPROCKET TOOTH WIDTH B ₁	24.1
SPROCKET TOOTH WIDTH b ₁	23.6
SPROCKET TOOTH WIDTH B ₂	72
SPROCKET TOOTH WIDTH B ₃	120.3

CHAIN	mm
PITCH	38.1
INNER WIDTH	25.4
ROLLER - ø	25.4

Cast iron sprockets in the ASA version are not manufactured

* = SINGLE SPROCKETS WITH DOUBLE REINFORCEMENT

P L A T E W H E E L S

Platewheels 20 x 16 mm

for roller chains in compliance with DIN 8164

Z	d_e	d_p	S
			D_1
12	85.7	77.28	14
14	98.3	89.88	14
15	104.6	96.18	14
16	110.9	102.52	16
17	117.2	108.82	16
19	129.9	121.52	16
20	136.2	127.84	16
21	142.6	134.18	20
23	155.3	146.88	20
26	174.3	165.92	20
27	180.7	172.27	20
35	231.5	223.12	20
38	250.6	242.18	25
39	256.9	248.54	25
40	263.3	254.92	25

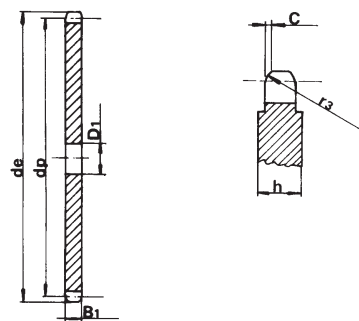

PLATEWHEEL — mm

TOOTH RADIUS r_3	20
RADIUS WIDTH C	1.7
PLATE TOOTH WIDTH B_1	14.5

CHAIN — mm

PITCH	20
INNER WIDTH	16
ROLLER - \varnothing	12

P L A T E W H E E L S

Platewheels 30 x 17.02 mm

for roller chains in compliance with DIN 8180

Z	d_e	d_p	S
			D_1
11	117.4	106.48	20
12	126.9	115.91	20
13	137.3	125.36	20
15	156.2	144.29	20
17	175.2	163.27	20
21	213.2	201.29	25
22	222.8	210.80	25
23	232.3	220.32	25
27	270.4	258.41	25
30	299.0	287.00	25
38	375.2	363.27	30

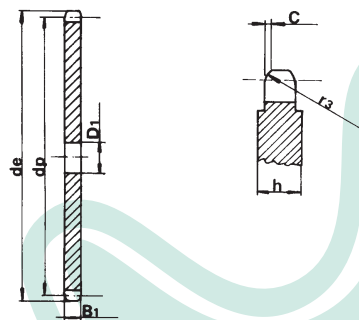

PLATEWHEEL — mm

TOOTH RADIUS r_3	27
RADIUS WIDTH C	2.2
PLATE TOOTH WIDTH B_1	15.8

CHAIN — mm

PITCH	30
INNER WIDTH	17.02
ROLLER - \varnothing	15.88

PLATEWHEELS FOR CONVEYORS AND ELEVATORS

Z	ROLLER 25			ROLLER 28			ROLLER 31		
	d _e	d _p	D ₁	d _e	d _p	D ₁	d _e	d _p	D ₁
6	115.0	100.00	20				116.2	100.00	20
7	132.7	115.24	20				133.8	115.24	20
8	148.1	130.60	25	150.2	130.60	25	152.3	130.60	25
9	163.7	146.20	25				167.9	146.20	25
10	179.3	161.85	25	181.4	161.85	25	183.5	161.85	25
11	195.0	177.50	25				199.2	177.50	25
12	211.0	193.20	25				212.0	193.20	25
13	226.4	208.95	30				230.6	208.95	30
14	242.2	224.70	30	244.3	224.70	30	246.4	224.70	30
15	257.9	240.45	30	260.0	240.45	30	262.1	240.45	30
16	273.8	256.30	30				278.0	256.30	30
17	289.5	272.05	30				293.7	272.05	30
18	305.4	287.95	30	307.5	287.95	30	309.6	287.95	30
19	321.3	303.80	30				325.5	303.80	30
20	337.1	319.60	30				341.3	319.60	30
21	352.9	335.45	30				357.1	335.45	30
22				370.9	351.35	30	373.0	351.35	30
23							388.9	367.20	30
24	400.0	383.05	30	402.6	383.05	30	404.7	383.05	30
25	416.4	398.95	30				419.7	398.95	30
26	432.3	414.80	30				436.5	414.80	30
27	448.2	430.70	30				452.4	430.70	30
28	464.0	446.55	30				468.2	446.55	30
30	495.8	478.35	30						
32							531.8	510.10	30
35							579.5	557.80	30
38	622.9	605.45	30				622.0	605.45	30

Platewheels P50

designed for conveyors and elevators

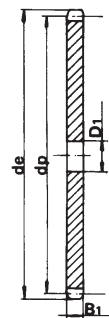

R 25 - 28 - 31

CHAIN	mm
PITCH	50
INNER WIDTH	11.5
ROLLER	25
PLATE THICKNESS B ₁	10.5
CHAIN	mm
PITCH	50
INNER WIDTH	15
ROLLER	28
PLATE THICKNESS B ₁	13.8
CHAIN	mm
PITCH	50
INNER WIDTH	15
ROLLER	31
PLATE THICKNESS B ₁	13.8

Z	ROLLER 25			ROLLER 31		
	d _e	d _p	D ₁	d _e	d _p	D ₁
8	213.4	195.98	30	217.6	195.98	30
9	236.8	219.30	30	241.0	219.30	30
10	260.2	242.77	30	264.4	242.77	30
11	283.7	266.25	30	287.9	266.25	30
12	307.3	289.80	30	311.5	289.80	30
13	330.9	313.42	30	334.1	313.42	30
14				358.7	337.05	30
15	378.1	360.67	30	382.3	360.67	30
16	401.9	384.45	30	406.1	384.45	30
17				429.7	408.07	30
20	496.9	479.40	30			
21				524.8	503.17	30
25	615.9	598.42	30	620.1	598.42	30

Platewheels P75

designed for conveyors and elevators

R 25 - 31

CHAIN	mm
PITCH	75
INNER WIDTH	11.5
ROLLER	25
PLATE THICKNESS B ₁	10.5
CHAIN	mm
PITCH	75
INNER WIDTH	15
ROLLER	31
PLATE THICKNESS B ₁	13.8

Z	ROLLER 25			ROLLER 31			ROLLER 40		
	d _e	d _p	D ₁	d _e	d _p	D ₁	d _e	d _p	D ₁
8	278.7	261.31	30	282.9	261.31	30	283	261.31	30
9				314.1	292.40	30	314	292.40	30
10	341.2	323.61	30	345.4	323.61	30	345	323.61	30
11	372.5	354.95	30	376.7	354.95	30	378	354.95	30
12	403.9	386.40	30	408.1	386.40	30	409	386.40	30
13				439.6	417.90	30			
14				471.1	449.40	30	473	449.40	30
15				502.6	480.90	30			
16				534.3	512.60	30	536	512.60	30
17				565.8	544.10	30			
18				597.6	575.90	30			
19									
20							663	639.20	30

Platewheels P100

Designed for conveyors and elevators

R 25 - 31 - 40

CHAIN	mm
PITCH	100
INNER WIDTH	11.5
ROLLER	25
PLATE THICKNESS B ₁	10.5
CHAIN	mm
PITCH	100
INNER WIDTH	15
ROLLER	31
PLATE THICKNESS B ₁	13.8
CHAIN	mm
PITCH	100
INNER WIDTH	22
ROLLER	40
PLATE THICKNESS B ₁	20

I D L E R S P R O C K E T S

Z

	Passo	d _e	dp	A	D1	F	B	H
23	8 x 3	62.15	58.75	2.8	16 ^{+0.26} / _{+0.13}	40	12	18.3
21	3/8" x 7/32"	68.00	63.90	5.3	16 ^{+0.26} / _{+0.13}	40	12	18.3
22	3/8" x 7/32"	71.00	66.93	5.3	16 ^{+0.26} / _{+0.13}	40	12	18.3
18	1/2" x 1/8"	78.90	73.14	3.0	16 ^{+0.26} / _{+0.13}	40	12	18.3
15	1/2" x 3/16"	66.80	61.09	4.5	16 ^{+0.26} / _{+0.13}	40	12	18.3
16	1/2" x 3/16"	70.90	65.10	4.5	16 ^{+0.26} / _{+0.13}	40	12	18.3
18	1/2" x 3/16"	78.90	73.13	4.5	16 ^{+0.26} / _{+0.13}	40	12	18.3
14	1/2" x 5/16"	61.80	57.07	7.2	16 ^{+0.26} / _{+0.13}	40	12	18.3
16	1/2" x 5/16"	69.50	65.10	7.2	16 ^{+0.26} / _{+0.13}	40	12	18.3
18	1/2" x 5/16"	77.80	73.14	7.2	16 ^{+0.26} / _{+0.13}	40	12	18.3
14	5/8" x 3/8"	78.00	71.34	9.1	16 ^{+0.26} / _{+0.13}	40	12	18.3
15	5/8" x 3/8"	83.00	76.36	9.1	16 ^{+0.26} / _{+0.13}	40	12	18.3
17	5/8" x 3/8"	93.00	86.39	9.1	16 ^{+0.26} / _{+0.13}	40	12	18.3
13	3/4" x 7/16"	87.50	79.59	11.1	16 ^{+0.26} / _{+0.13}	40	12	18.3
15	3/4" x 7/16"	99.80	91.63	11.1	16 ^{+0.26} / _{+0.13}	40	12	18.3
12	1" x 17.02	109.00	98.14	16.2	20 ^{+0.26} / _{+0.1}	47	14	17.7
13	1 1/4" x 3/4"	147.80	132.65	18.5	25 ^{+0.26} / _{+0.1}	52	15	21.0

Our chain tensioning sprockets are supplied complete with bearing, ready for assembly in special tension or transmission points. The accurate machining and stable assembly on a dual protective shield ball bearing ensure greater resistance to loads and wear. The central elongated ring of the bearing facilitates assembly on special machines of every type.

Idler Sprockets with ball bearing

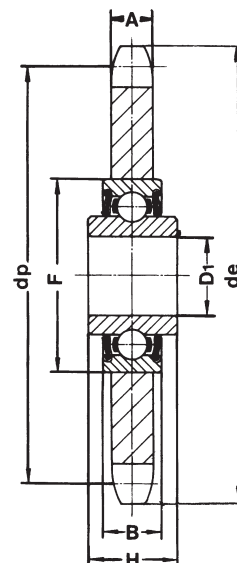

DISASSEMBLING HUBS FOR PLATEWHEELS

Nr.

	d _e	d _i	d _m ^{h9}	A	D _f	B ₁	H ₁
30	55	45	30	20.0	4.2	4	3.0
40	70	58	40	25.0	5.2	5	5.2
50	80	67	50	32.0	6.2	7	7.0
60	90	76	60	38.5	6.2	7	8.7
70	110	94	70	45.5	8.2	8	10.5
80	130	107	80	55.0	8.2	12	15.0
100	170	140	100	73.0	10.2	17	23.0
140	220	182	140	83.0	12.2	20	23.0
160	245	205	160	93.0	16.5	25	25.0

One sided hub for chain wheel

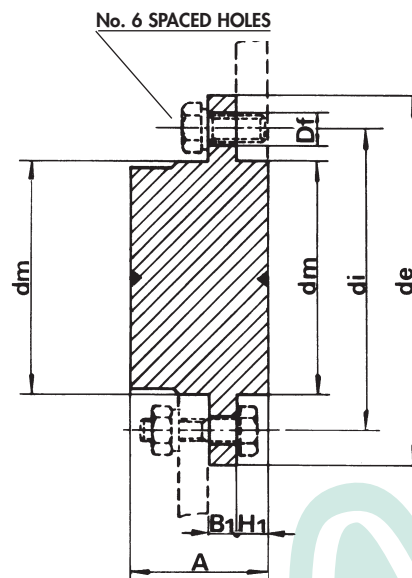

MATERIAL: FE 50

T A B L E T O P W H E E L S

Z

	d _e	D1	L
13	78.98	15	43.5
15	93.67	15	43.5
17	105.47	20	43.5
19	117.34	20	43.5
21	129.26	20	43.5
23	141.22	20	43.5
25	153.21	20	43.5
27	165.20	20	43.5
29	177.24	20	43.5
31	189.28	20	43.5

Tabletop wheels P.1 1/2 in compliance with DIN 8153

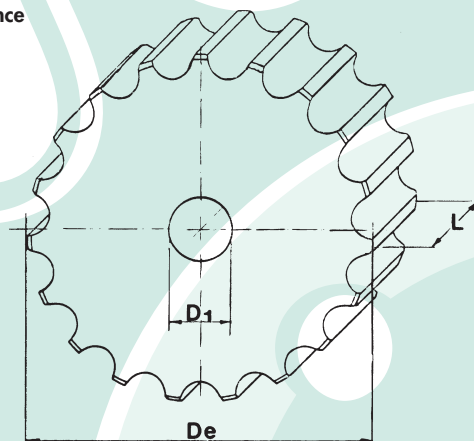

MATERIAL: FE 50

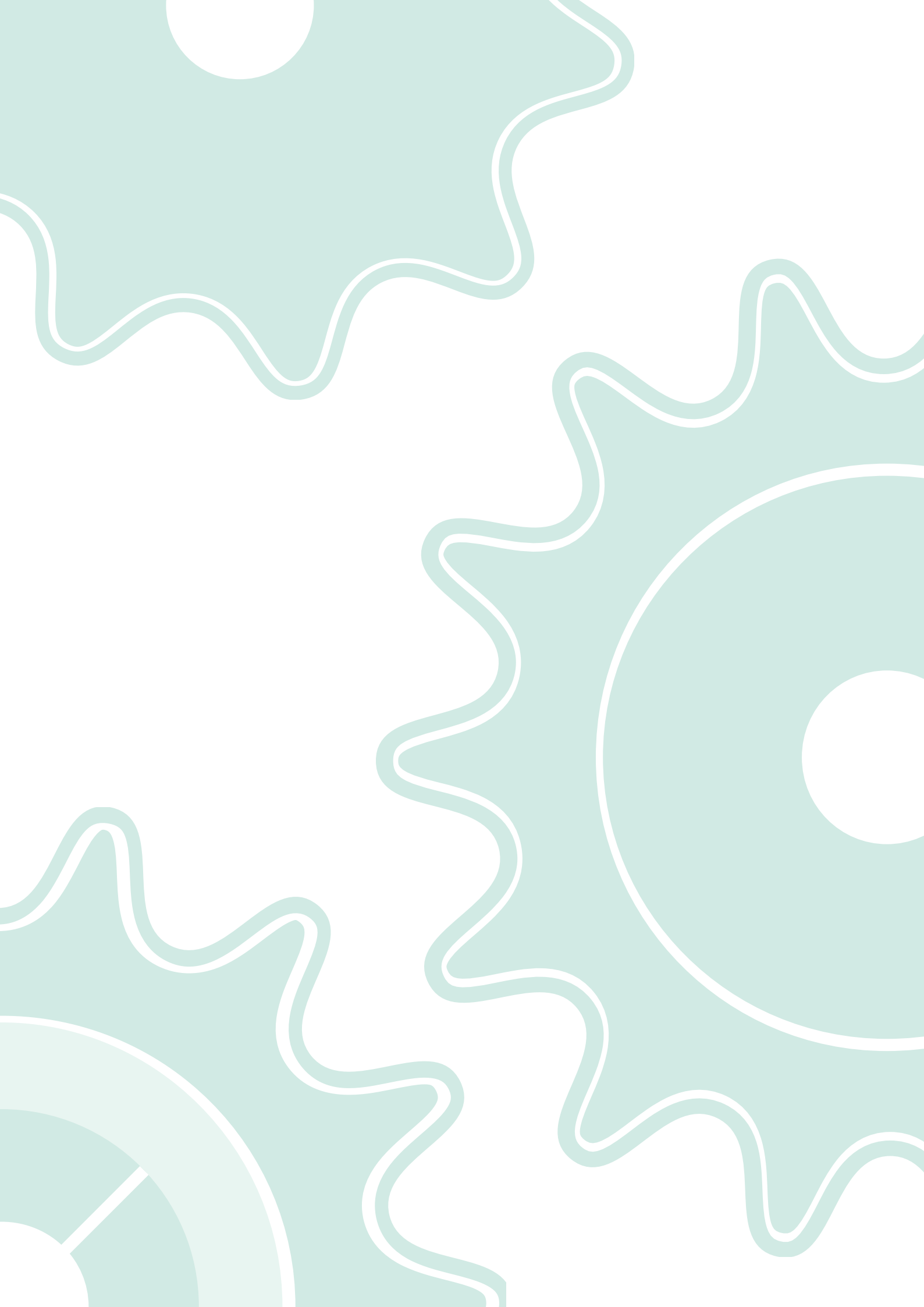

T P M[®] - R O L L E R C H A I N S

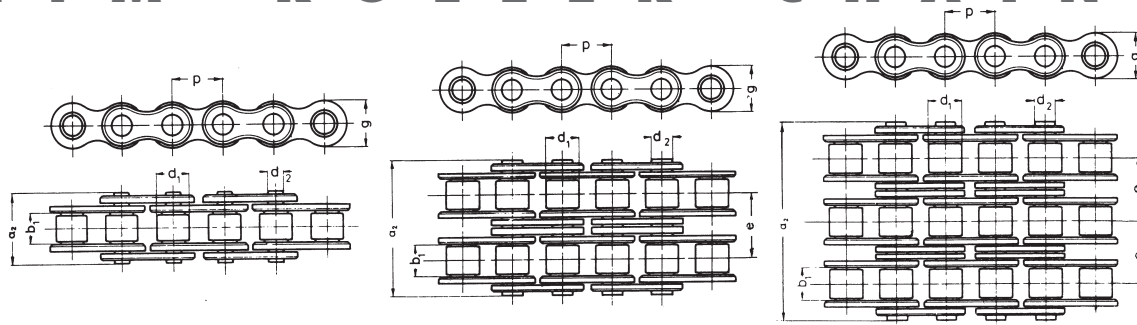

ISO N.	SINGLE										
	mm	P	inch	b ₁ min. mm	d ₂ mm	d ₁ max. mm	α ² max. mm	g max. mm	f cm ²	kg/m =	ult. tensile strength N. min.
081-1	12.7		1/2"	3.3	3.59	7.75	10.2	9.90	0.20	0.28	7.200
083-1	12.7		1/2"	4.88	4.09	7.75	12.9	10.30	0.32	0.42	9.200
084-1	12.7		1/2"	4.88	4.09	7.75	14.8	11.15	0.35	0.59	11.000

Q R C[®] - R O L L E R C H A I N S

CHAINS MANUFACTURED BY AN ISO 9002 CERTIFIED FACTORY

ISO N.	SINGLE										
	mm	P	inch	b ₁ min. mm	d ₂ mm	d ₁ max. mm	α ² max. mm	g max. mm	f cm ²	kg/m =	ult. tensile strength N. min.
04-1	6		-	2.80	1.85	4.00	7.4	5.00	0.07	0.12	2.800
05B-1	8		-	3.00	2.31	5.00	8.6	7.11	0.11	0.18	4.700
06B-1	9.525		3/8"	5.72	3.28	6.35	13.5	8.26	0.28	0.41	8.200
08B-1	12.7		1/2"	7.75	4.45	8.51	17.0	11.81	0.50	0.70	16.400
10B-1	15.875		5/8"	9.65	5.08	10.16	19.6	14.73	0.67	0.95	20.500
12B-1	19.05		3/4"	11.68	5.72	12.07	22.7	16.13	0.89	1.25	26.500
16B-1	25.04		1"	17.02	8.28	15.88	36.1	21.08	2.10	2.70	52.500
20B-1	31.75		1 1/4"	19.56	10.19	19.05	43.2	26.42	2.95	3.60	85.500
24B-1	38.1		1 1/2"	25.40	14.63	25.40	53.4	33.40	5.54	6.70	153.900
28B-1	44.45		1 3/4"	30.99	15.90	27.94	65.1	37.08	7.40	8.30	180.000
32B-1	50.8		2"	30.99	17.81	29.21	67.4	42.29	8.11	10.50	230.000

ISO N.	DOUBLE											
	mm	P	inch	b ₁ min. mm	d ₂ mm	d ₁ max. mm	α ² max. mm	g max. mm	e mm	f cm ²	kg/m =	ult. tensile strength N. min.
06B-2	9.525		3/8"	5.72	3.28	6.35	23.8	8.26	10.24	0.55	0.78	15.500
08B-2	12.7		1/2"	7.75	4.45	8.51	31.0	11.81	13.92	1.00	1.35	28.500
10B-2	15.875		5/8"	9.65	5.08	10.16	36.2	14.73	16.59	1.34	1.85	41.000
12B-2	19.05		3/4"	11.68	5.72	12.07	42.2	16.13	19.46	1.78	2.50	53.000
16B-2	25.4		1"	17.02	8.28	15.88	68.0	21.08	31.88	4.21	5.40	99.500
20B-2	31.75		1 1/4"	19.56	10.19	19.05	79.7	26.42	35.45	5.91	7.20	162.000
24B-2	38.1		1 1/2"	25.40	14.63	25.40	101.8	33.40	48.36	11.09	13.50	293.000
28B-2	44.45		1 3/4"	30.99	15.90	27.94	124.7	37.08	59.56	14.81	16.60	344.000
32B-2	50.8		2"	30.99	17.81	29.21	126.0	42.29	58.55	16.23	21.00	440.000

ISO N.	TRIPLE											
	mm	P	inch	b ₁ min. mm	d ₂ mm	d ₁ max. mm	α ² max. mm	g max. mm	e mm	f cm ²	kg/m =	ult. tensile strength N. min.
06B-3	9.525		3/8"	5.72	3.28	6.35	34.0	8.26	10.24	0.83	1.2	22.800
08B-3	12.7		1/2"	7.75	4.45	8.51	44.9	11.81	13.92	1.50	2.0	41.000
10B-3	15.875		5/8"	9.65	5.08	10.16	52.8	14.73	16.59	2.02	2.8	61.500
12B-3	19.05		3/4"	11.68	5.72	12.07	61.7	16.13	19.46	2.68	3.8	80.000
16B-3	25.4		1"	17.02	8.28	15.88	99.9	21.08	31.88	6.32	8.0	149.000
20B-3	31.75		1 1/4"	19.56	10.19	19.05	116.1	26.42	36.45	8.86	11.0	244.000
24B-3	38.1		1 1/2"	25.40	14.63	25.40	150.2	33.40	48.36	16.64	21.0	438.000
28B-3	44.45		1 3/4"	30.99	15.90	27.94	184.3	37.08	59.56	22.21	25.0	516.000
32B-3	50.8		2"	30.99	17.81	29.21	184.5	42.29	58.55	24.34	32.0	671.000

Q R C[®] ASA - ROLLER CHAINS

CHAINS MANUFACTURED BY AN ISO 9002 CERTIFIED FACTORY

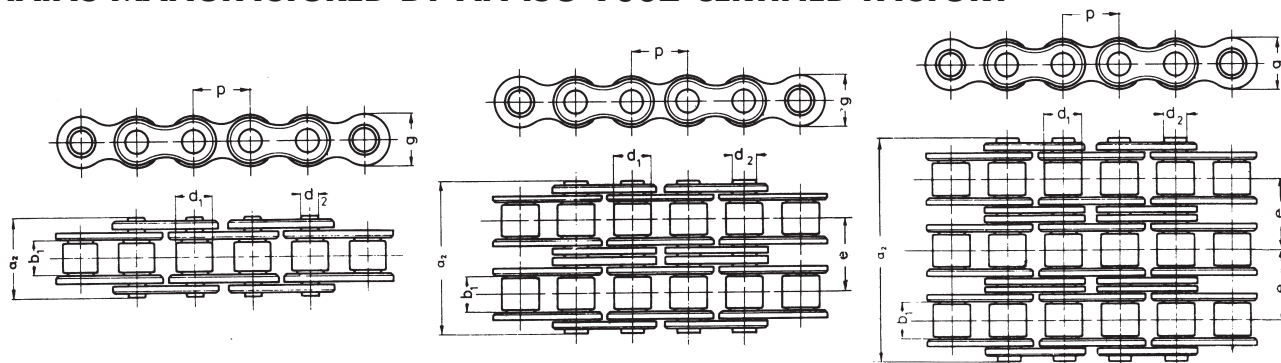

ANSI N.

SINGLE "ANSI" ASA

	mm	P	inch	b ₁ min. mm	d ₂ mm	d ₁ max. mm	a ² max. mm	g max. mm	f cm ²	kg/m =	ult. tensile strength N. min.
35-1	9.525		3/8"	4.77	3.58	5.08	13.2	9.05	0.27	0.31	7.350
40-1	12.7		1/2"	7.95	3.96	7.92	17.8	12.07	0.44	0.61	12.900
50-1	15.875		5/8"	9.53	5.08	10.16	21.8	15.09	0.70	1.01	20.200
60-1	19.05		3/4"	12.70	5.94	11.91	26.9	18.08	1.06	1.47	28.900
80-1	25.4		1"	15.88	7.92	15.88	33.5	24.13	1.79	2.57	51.300
100-1	31.75		1 1/4"	19.05	9.53	19.05	41.1	30.18	2.62	3.73	80.200
120-1	38.1		1 1/2"	25.40	11.10	22.23	50.8	36.20	3.94	5.50	115.000
140-1	44.45		1 3/4"	25.40	12.70	25.40	54.9	42.24	4.72	7.50	156.300
160-1	50.8		2"	31.75	14.27	28.58	65.5	48.26	6.50	9.70	205.500

ANSI N.

DOUBLE "ANSI" ASA

	mm	P	inch	b ₁ min. mm	d ₂ mm	d ₁ max. mm	a ² max. mm	g max. mm	e mm	f cm ²	kg/m =	ult. tensile strength N. min.
35-2	9.525		3/8"	4.77	3.58	5.08	21.6	9.05	10.13	0.54	0.67	14.700
40-2	12.7		1/2"	7.95	3.96	7.92	32.3	12.07	14.38	0.88	1.19	25.600
50-2	15.875		5/8"	9.53	5.08	10.16	39.9	15.09	18.11	1.40	1.92	40.400
60-2	19.05		3/4"	12.70	5.94	11.91	49.8	18.08	22.78	2.12	2.90	57.800
80-2	25.4		1"	15.88	7.92	15.88	62.7	24.13	29.29	3.58	5.01	102.700
100-2	31.75		1 1/4"	19.05	9.53	19.05	77.0	30.18	35.76	5.24	7.31	160.400
120-2	38.1		1 1/2"	25.40	11.10	22.23	96.3	36.20	45.44	7.88	10.94	230.000
140-2	44.45		1 3/4"	25.40	12.70	25.40	103.6	42.24	48.87	9.44	14.36	312.600
160-2	50.8		2"	31.75	14.27	28.58	124.2	48.26	58.55	13.00	19.10	411.000

ANSI N.

TRIPLE "ANSI" ASA

	mm	P	inch	b ₁ min. mm	d ₂ mm	d ₁ max. mm	a ² max. mm	g max. mm	e mm	f cm ²	kg/m =	ult. tensile strength N. min.
35-3	9.525		3/8"	4.77	3.58	5.08	31.8	9.05	10.13	0.81	1.01	22.050
40-3	12.7		1/2"	7.95	3.96	7.92	46.7	12.07	14.38	1.32	1.78	38.300
50-3	15.875		5/8"	9.53	5.08	10.16	57.9	15.09	18.11	2.10	2.89	60.600
60-3	19.05		3/4"	12.70	5.94	11.91	72.6	18.08	22.78	3.18	4.28	86.700
80-3	25.4		1"	15.88	7.92	15.88	91.7	24.13	29.29	5.37	7.47	154.100
100-3	31.75		1 1/4"	19.05	9.53	19.05	113.0	30.18	35.76	7.86	11.01	240.600
120-3	38.1		1 1/2"	25.40	11.10	22.23	141.7	36.20	45.44	11.82	16.50	345.000
140-3	44.45		1 3/4"	25.40	12.70	25.40	152.4	42.24	48.87	14.16	21.70	468.900
160-3	50.8		2"	31.75	14.27	28.58	182.9	48.26	58.55	19.50	28.30	616.400

Q R C® - EUROPEAN RANGE ROLLER CHAINS

CHAINS MANUFACTURED BY AN ISO 9002 CERTIFIED FACTORY

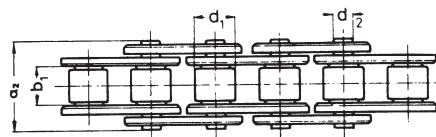
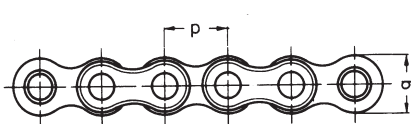

ISO N.

SINGLE - STAINLESS STEEL

	mm	P	inch	b ₁ min. mm	d ₂ mm	d ₁ max. mm	a ² max. mm	g max. mm	f cm ²	kg/m =	ult. tensile strength N. min.
05B-1	8	-	-	3.00	2.31	5.00	8.6	7.11	0.11	0.18	3.400
06B-1	9.525	3/8"	3/8"	5.72	3.28	6.35	13.5	8.26	0.28	0.41	4.400
08B-1	12.7	1/2"	1/2"	7.75	4.45	8.51	17.0	11.81	0.50	0.70	9.800
10B-1	15.875	5/8"	5/8"	9.65	5.08	10.16	19.6	14.73	0.67	0.95	13.600
12B-1	19.05	3/4"	3/4"	11.68	5.72	12.07	22.7	16.13	0.89	1.25	15.000
16B-1	25.4	1"	1"	17.02	8.28	15.88	36.1	21.08	2.10	2.70	39.500

ISO N.

DOUBLE - STAINLESS STEEL

	mm	P	inch	b ₁ min. mm	d ₂ mm	d ₁ max. mm	a ² max. mm	g max. mm	e mm	f cm ²	kg/m =	ult. tensile strength N. min.
06B-2	9.525	3/8"	3/8"	5.72	3.28	6.35	23.8	8.26	10.24	0.55	0.78	8.400
08B-2	12.7	1/2"	1/2"	7.75	4.45	8.51	31.0	11.81	13.92	1.00	1.35	16.950
10B-2	15.875	5/8"	5/8"	9.65	5.08	10.16	36.2	14.73	16.59	1.34	1.85	27.000
12B-2	19.05	3/4"	3/4"	11.68	5.72	12.07	42.2	16.13	19.46	1.78	2.50	29.700
16B-2	25.4	1"	1"	17.02	8.28	15.88	68.0	21.08	31.88	4.21	5.40	69.000

ISO N.

NICKEL-PLATED

	mm	P	inch	b ₁ min. mm	d ₂ mm	d ₁ max. mm	a ² max. mm	g max. mm	f cm ²	kg/m =	ult. tensile strength N. min.
06B-1	9.525	3/8"	3/8"	5.72	3.28	6.35	13.5	8.26	0.28	0.41	8.200
08B-1	12.7	1/2"	1/2"	7.75	4.45	8.51	17.0	11.81	0.50	0.70	16.400
10B-1	15.875	5/8"	5/8"	9.65	5.08	10.16	19.6	14.73	0.67	0.95	20.500
12B-1	19.05	3/4"	3/4"	11.68	5.72	12.07	22.7	16.13	0.89	1.25	26.500
16B-1	25.4	1"	1"	17.02	8.28	15.88	36.1	21.08	2.10	2.70	52.500

STRAIGHT LINK PLATE CHAINS

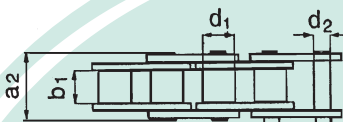
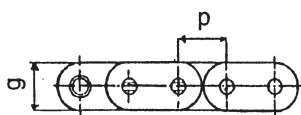

ISO N.

STRAIGHT LINK PLATES

	mm	P	inch	b ₁ min. mm	d ₂ mm	d ₁ max. mm	a ² max. mm	g max. mm	f cm ²	kg/m =	ult. tensile strength N. min.
08B-1	12.7	1/2"	1/2"	7.75	4.45	8.51	17.0	11.81	0.50	0.80	17.000
10B-1	15.875	5/8"	5/8"	9.65	5.08	10.16	19.6	14.73	0.67	1.00	22.000
12B-1	19.05	3/4"	3/4"	11.68	5.72	12.07	22.7	16.13	0.89	1.30	28.000
16B-1	25.4	1"	1"	17.02	8.28	15.88	36.1	21.08	2.10	2.90	57.000
12B-2	19.05	3/4"	3/4"	11.68	5.72	12.07	42.2	16.13	1.78	2.60	60.000

H O L L O W P I N C H A I N S

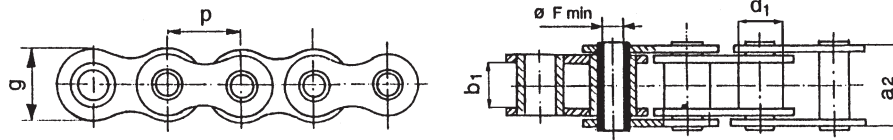

STRAIGHT LINK PLATES

REFERENCE No.

	mm	P	inch	b ₁ min. mm	d ₁ mm	a ² max. mm	F min. mm	g max. mm	f cm ²	kg/m =	ult. tensile strength N. min.
12B-44	12.7		1/2"	7.75	8.51	17.0	4.4	11.7	0.7	0.50	13.500
15B-51	15.875		5/8"	9.65	10.16	21.0	5.1	14.0	1.0	0.80	20.000

N.B. All the QRC® chains are subjected to 1/3 pre-tensioning compared with the minimum ultimate tensile strength to avoid elongation.

R C X[®] - EUROPEAN ROLLER CHAINS

CHAINS MANUFACTURED BY AN ISO 9001 CERTIFIED FACTORY

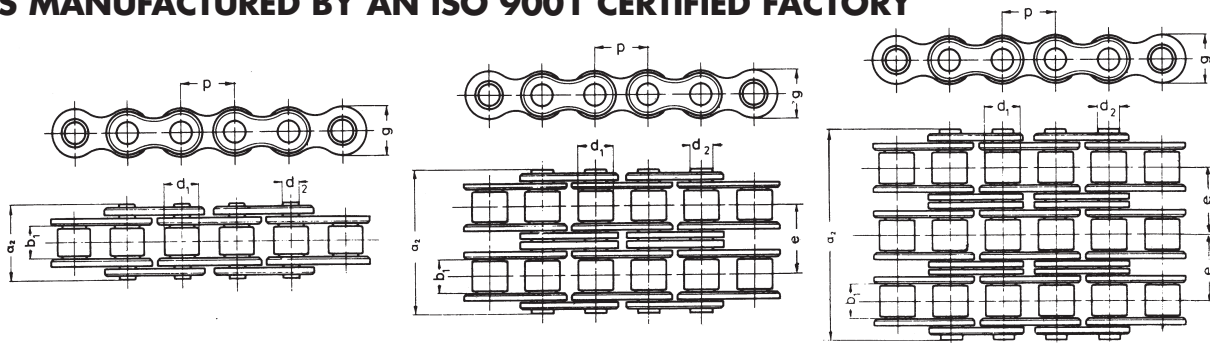

ISO N.

SINGLE

	mm	P	inch	b ₁ min. mm	d ₂ mm	d ₁ max. mm	a ² max. mm	g max. mm	f cm ²	kg/m =	ult. tensile strength N. min.
04-1	6		-	2.80	1.85	4.00	7.4	5.00	0.07	0.12	3.000
05B-1	8		-	3.00	2.31	5.00	8.6	7.11	0.11	0.18	5.000
06B-1	9.525		3/8"	5.72	3.28	6.35	13.5	8.26	0.28	0.41	9.000
08B-1	12.7		1/2"	7.75	4.45	8.51	17.0	11.81	0.50	0.70	18.000
10B-1	15.875		5/8"	9.65	5.08	10.16	19.6	14.73	0.67	0.95	23.500
12B-1	19.05		3/4"	11.68	5.72	12.07	22.7	16.13	0.89	1.25	29.400
16B-1	25.4		1"	17.02	8.28	15.88	36.1	21.08	2.10	2.70	66.700
20B-1	31.75		1 1/4"	19.56	10.19	19.05	43.2	26.42	2.95	3.60	96.000
24B-1	38.1		1 1/2"	25.40	14.63	25.40	53.4	33.40	5.54	6.70	160.000
32B-1	50.8		2"	30.99	17.81	29.21	67.4	42.29	8.11	10.50	257.800

ISO N.

DOUBLE

	mm	P	inch	b ₁ min. mm	d ₂ mm	d ₁ max. mm	a ² max. mm	g max. mm	e mm	f cm ²	kg/m =	ult. tensile strength N. min.
05B-2	8		-	3.00	2.31	5.00	14.3	7.10	5.64	0.22	0.36	9.800
06B-2	9.525		3/8"	5.72	3.28	6.35	23.8	8.26	10.24	0.55	0.78	17.000
08B-2	12.7		1/2"	7.75	4.45	8.51	31.0	11.81	13.92	1.00	1.35	34.000
10B-2	15.875		5/8"	9.65	5.08	10.16	36.2	14.73	16.59	1.34	1.85	47.000
12B-2	19.05		3/4"	11.68	5.72	12.07	42.2	16.13	19.46	1.78	2.50	58.000
16B-2	25.4		1"	17.02	8.28	15.88	68.0	21.08	31.88	4.21	5.40	133.200
20B-2	31.75		1 1/4"	19.56	10.19	19.05	79.7	26.42	35.45	5.91	7.20	192.000
24B-2	38.1		1 1/2"	25.40	14.63	25.40	101.8	33.40	48.36	11.09	13.50	320.500

ISO N.

TRIPLE

	mm	P	inch	b ₁ min. mm	d ₂ mm	d ₁ max. mm	a ² max. mm	g max. mm	e mm	f cm ²	kg/m =	ult. tensile strength N. min.
06B-3	9.525		3/8"	5.72	3.28	6.35	34.0	8.26	10.24	0.83	1.2	26.400
08B-3	12.7		1/2"	7.75	4.45	8.51	44.9	11.81	13.92	1.50	2.0	49.000
10B-3	15.875		5/8"	9.65	5.08	10.16	52.8	14.73	16.59	2.02	2.8	70.000
12B-3	19.05		3/4"	11.68	5.72	12.07	61.7	16.13	19.46	2.68	3.8	88.000
16B-3	25.4		1"	17.02	8.28	15.88	99.9	21.08	31.88	6.32	8.0	196.000

R C X[®] - STAINLESS STEEL EUROPEAN ROLLER CHAINS

CHAINS MANUFACTURED BY AN ISO 9001 CERTIFIED FACTORY

ISO N.	SINGLE										
	mm	P	inch	b ₁ min. mm	d ₂ mm	d ₁ max. mm	a ² max. mm	g max. mm	f cm ²	kg/m =	ult. tensile strength N. min.
06B-1	9.525		3/8"	5.72	3.28	6.35	13.5	8.26	0.28	0.41	5.800
08B-1	12.7		1/2"	7.75	4.45	8.51	17.0	11.81	0.50	0.70	10.700
10B-1	15.875		5/8"	9.65	5.08	10.16	19.6	14.73	0.67	0.95	14.700
12B-1	19.05		3/4"	11.68	5.72	12.07	22.7	16.13	0.89	1.25	18.600
16B-1	25.4		1"	17.02	8.28	15.88	36.1	21.08	2.10	2.70	45.000

ISO N.	DOUBLE											
	mm	P	inch	b ₁ min. mm	d ₂ mm	d ₁ max. mm	a ² max. mm	g max. mm	e mm	f cm ²	kg/m =	ult. tensile strength N. min.
06B-2	9.525		3/8"	5.72	3.28	6.35	23.8	8.26	10.24	0.55	0.78	11.500
08B-2	12.7		1/2"	7.75	4.45	8.51	31.0	11.81	13.92	1.00	1.35	21.200
10B-2	15.875		5/8"	9.65	5.08	10.16	36.2	14.73	16.59	1.34	1.85	29.300
12B-2	19.05		3/4"	11.68	5.72	12.07	42.2	16.13	19.46	1.78	2.50	37.000
16B-2	25.4		1"	17.02	8.28	15.88	68.0	21.08	31.88	4.21	5.40	79.800

R C X[®] - ANSI ROLLER CHAINS

CHAINS MANUFACTURED BY AN ISO 9001 CERTIFIED FACTORY

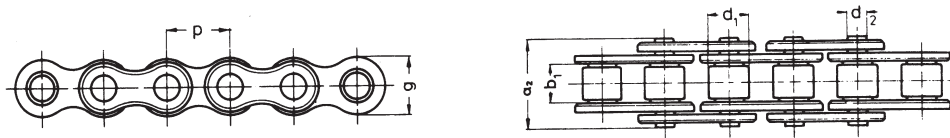

ANSI N.	SINGLE										
	mm	P	inch	b ₁ min. mm	d ₂ mm	d ₁ max. mm	a ² max. mm	g max. mm	f cm ²	kg/m =	ult. tensile strength N. min.
40-1	12.7		1/2"	7.95	3.96	7.92	17.8	12.07	0.44	0.61	16.600
50-1	15.875		5/8"	9.53	5.08	10.16	21.8	15.09	0.70	1.01	26.400
60-1	19.05		3/4"	12.7	5.94	11.91	26.9	18.08	1.06	1.47	37.200
80-1	25.4		1"	15.88	7.92	15.88	33.5	24.13	1.79	2.57	70.600
100-1	31.75		1 1/4"	19.05	9.53	19.05	41.1	30.18	2.62	3.73	108.700
120-1	38.1		1 1/2"	25.40	11.10	22.23	50.8	36.20	3.94	5.50	138.000

REINFORCED ANSI ROLLER CHAINS

ANSI N.	SINGLE										
	mm	P	inch	b ₁ min. mm	d ₂ mm	d ₁ max. mm	a ² max. mm	g max. mm	f cm ²	kg/m =	ult. tensile strength N. min.
60 H-1	19.05		3/4"	12.70	5.94	11.91	28.9	18.08	1.06	1.70	49.000
80 H-1	25.4		1"	15.88	7.92	15.88	36.5	24.13	1.79	2.90	84.800
100 H-1	31.75		1 1/4"	19.05	9.53	19.05	42.9	30.18	2.62	4.40	122.600
120 H-1	38.1		1 1/2"	25.40	11.11	22.22	54.1	36.19	4.00	6.20	160.500

N.B. All the RCX[®] chains are subjected to 1/3 pre-tensioning compared with the minimum ultimate tensile strength to avoid elongation.

CRT[®] - CONVEYOR CHAINS

CHAINS MANUFACTURED BY AN ISO 9001 CERTIFIED FACTORY

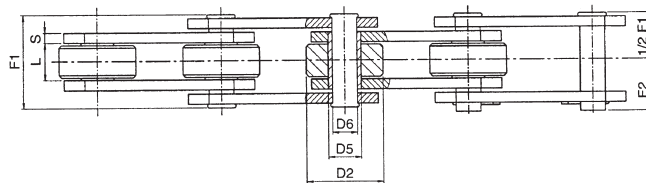
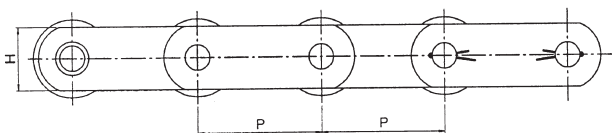

CHAIN

SOLID PINS TYPE

	P mm	L mm	D2 mm	D5 mm	D6 mm	H mm	S mm	F1 mm	F2 mm	ult. tensile strength N. min.	chain weight Kg.m
1.1205	50	11.5	25	8.35	5.7	18	2.5	25.5	15.4	18.000	1.7
1.1206	50	11.5	25	11	8	20	3	28.8	16.5	22.000	1.9
1.1400	50	15	31	13.2	10	23	3	32.6	19.2	32.000	3
1.1500	50	15	31	13.2	10	25	4	36.6	20.7	40.000	3.9
1.1502	100	15	31	13.2	10	25	4	36.6	20.7	40.000	2.7
1.1703	100	22	40	17	12	35	4	44	25	75.000	4.9

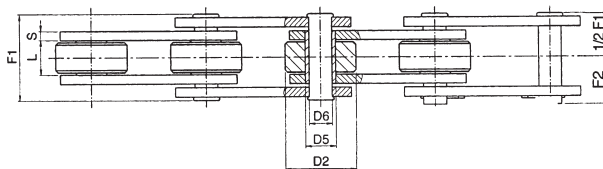
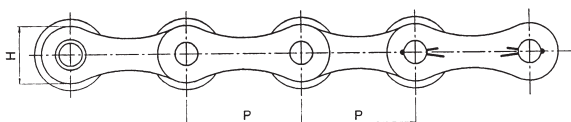

CHAIN

SOLID PINS "B" TYPE

	P mm	L mm	D2 mm	D5 mm	D6 mm	H mm	S mm	F1 mm	F2 mm	ult. tensile strength N. min.	chain weight Kg.m
1.1400 B	50	15	31	13.2	10	23	3	32.6	19.2	32.000	2.5

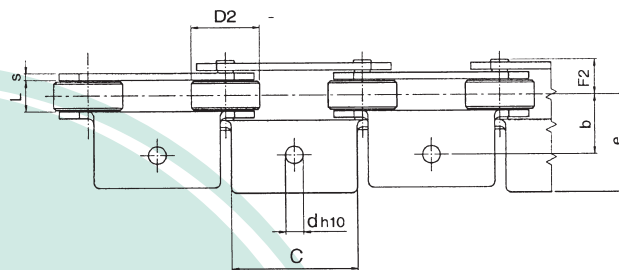
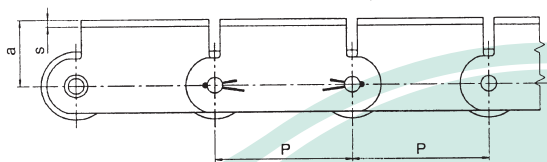

CHAIN

SOLID PINS TYPE WITH ATTACHMENTS

	P mm	D2 mm	a mm	b mm	c mm	d mm	e mm	s mm	L mm	F2 mm	ult. tensile strength N. min.	chain weight Kg.
1.1205 A1-01	50	25	24	22	46	6.5	36	2.5	11.5	12.75	18.000	0.035

CRT[®] - CONVEYOR CHAINS

CHAINS MANUFACTURED BY AN ISO 9001 CERTIFIED FACTORY

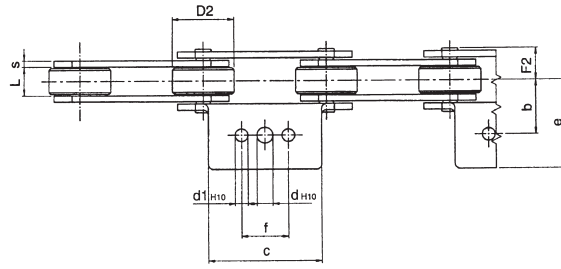
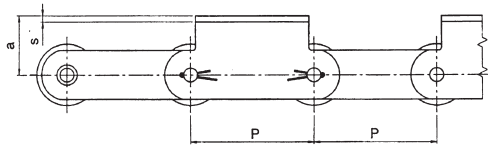

CHAIN

SOLID PINS TYPE WITH ATTACHMENTS

	P mm	D2 mm	a mm	b mm	c mm	d mm	e mm	s mm	d1 mm	f mm	L mm	F2 mm	ult. tensile strength N. min.	chain weight Kg.
1.1205 A1-02	50	25	24	22	46	6.5	36	2.5			11.5	12.75	18.000	0.035
1.1400 A1-02	50	31	35	31	60	10.5	48.5	3	8.5	25	15	16.3	32.000	0.050
1.1500 A1-02	50	31	35	32	45	10.5	48	4	8.5	25	15	18.7	40.000	0.070

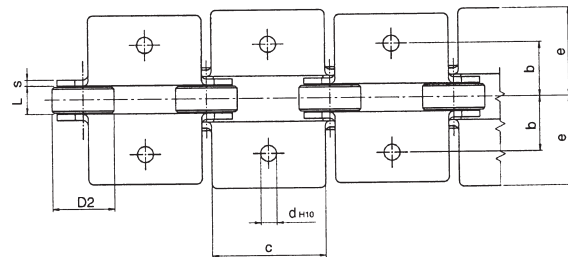
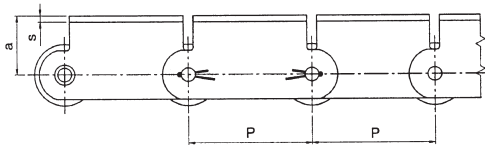

CHAIN

SOLID PINS TYPE WITH ATTACHMENTS

	P mm	D2 mm	a mm	b mm	c mm	d mm	e mm	s mm	L mm	ult. tensile strength N. min.	chain weight Kg.
1.1205 K1-01	50	25	24	22	46	6.5	36	2.5	11.5	18.000	0.035

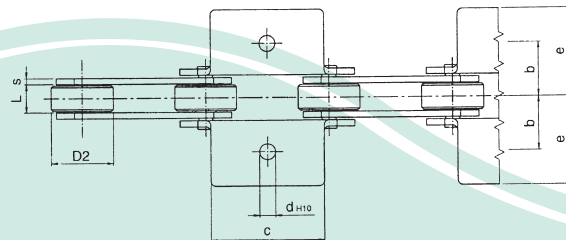
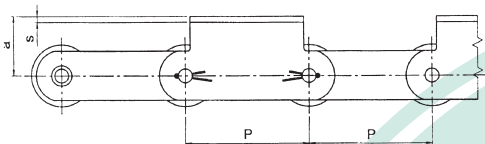

CHAIN

SOLID PINS TYPE WITH ATTACHMENTS

	P mm	D2 mm	a mm	b mm	c mm	d mm	e mm	s mm	L mm	ult. tensile strength N. min.	chain weight Kg.
1.1205 K1-02	50	25	24	22	46	6.5	36	2.5	11.5	18.000	0.035

CRT® - CONVEYOR CHAINS

CHAINS MANUFACTURED BY AN ISO 9001 CERTIFIED FACTORY

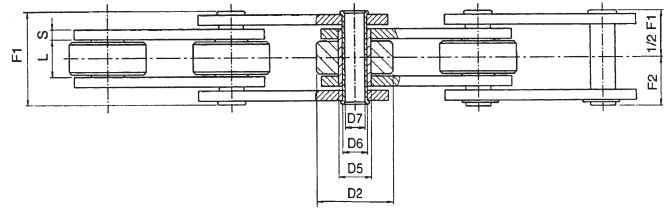
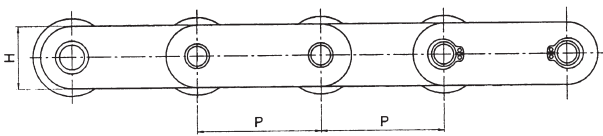

CHAIN

HOLLOW PINS TYPE

	P mm	L mm	D2 mm	D5 mm	D6 mm	D7 mm	H mm	S mm	F1 mm	F2 mm	ult. tensile strength N. min.	chain weight Kg.m
1.2250	50	11.5	25	11	9	6.2	20	2.5	26	14.5	30.000	1.8
*1.2250 SS	50	11.5	25	11	9	6.2	20	2.5	26	14.5	20.000	1.8
1.2400	50	15	31	17	14	10.2	25	3	31	17.5	35.000	3.0
1.2500	50	15	31	17	14	10.2	25	4	35	19.5	40.000	3.6
1.2501	75	15	31	17	14	10.2	25	4	35	19.5	40.000	3.1
1.2502	100	15	31	17	14	10.2	25	4	35	19.5	40.000	2.6

* Inox

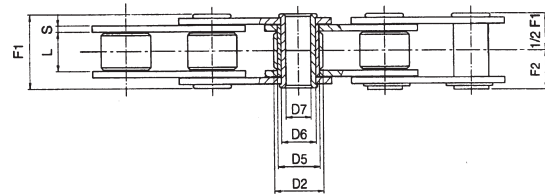
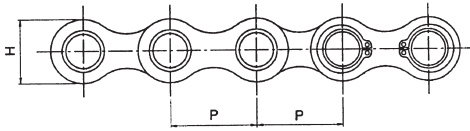

CHAIN

HOLLOW PINS TYPE

	P mm	L mm	D2 mm	D5 mm	D6 mm	D7 mm	H mm	S mm	F1 mm	F2 mm	ult. tensile strength N. min.	chain weight Kg.m
*1.3520Z	35	16	20	17	14	10.2	26	2.5	30	16.7	25.000	2.2
1.3520R	35	16	20	17	14	10.2	26	2.5	30	16.7	37.000	2.2

* Galvanise

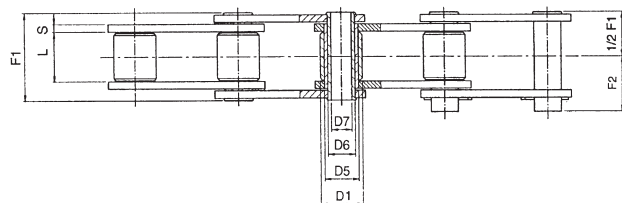
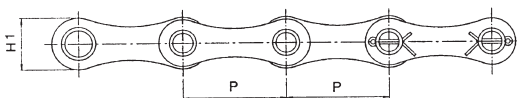

CHAIN

HOLLOW PINS TYPE - GALVANISED

	P mm	L mm	D2 mm	D5 mm	D6 mm	D7 mm	H1 mm	S mm	F1 mm	F2 mm	ult. tensile strength N. min.	chain weight Kg.m
1.1260Z	41.75	20.5	17	13.8	11	8.3	21.4	3	36	22.7	27.000	1.5

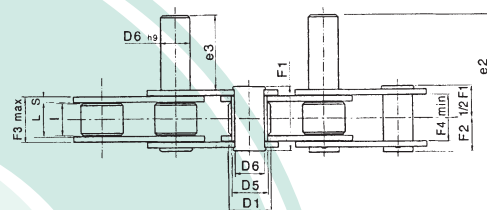
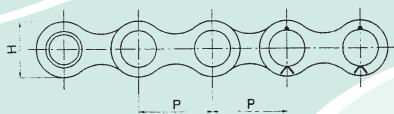

CHAIN

EXTENDED PINS - GALVANISED

	P mm	L mm	D2 mm	D5 mm	D6 mm	e2 mm	H mm	S mm	F1 mm	F2 mm	e3 mm	F3 max mm	F4 min mm	ult. tensile strength N. min.	chain weight Kg.m
1.3521Z	35	16	20	13	10	48.5	26	2.5	31	19	35	21	21.5	35.000	2.8

N.B. All the CRT® chains are subjected to 1/3 pre-tensioning compared with the minimum ultimate tensile strength to avoid elongation.

POLYETHYLENE CHAIN GUIDE RAILS

Material: PE-UHMW

High molecular weight polyethylene (Mol. weight higher than 1,000,000).

Colour: green - standard length 2 m. - 3 - 4 m. on request

Specific weight: 0.945 g/cm³.

Dynamic friction coefficient: 0.2 (P = 0.05 N/mm² - V = 0.6 m/s - T = 40°C).

Operating temperature: -200°C ÷ 60°C. For short periods by contact: 80°C.

Linear thermal expansion: 2 mm every 10°C starting from a room temperature of 20°C.

"T" profile for single chain		Chain	ISO	Guide dimensions		Weight Kg.m
AxB	H			W		
GC-T-06	10x15	3/8"x7/32"	06 B-1	1.5	5.4	0.130
GC-T-08	10x20 15x20 20x20	1/2"x5/16"	08 B-1	2.2	7.4	0.175 0.260 0.340
GC-T-10	15x20 20x20	5/8"x3/8"	10 B-1	2.6	9.2	0.250 0.333
GC-T-12	15x25 20x25	3/4"x7/16"	12 B-1	2.4	11.3	0.320 0.430
GC-T-16	15x40 20x40	1"17.02 mm	16 B-1	3.5	16.5	0.450 0.675

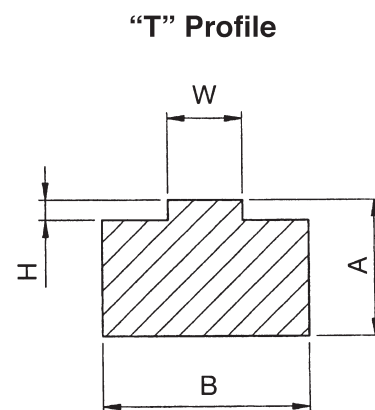

"T2" profile for double chain		Chain	ISO	Guide dimensions			Weight Kg.m
AxB	H			M2	W		
GC-T2-06	10x25	3/8"x7/32"	06 B-2	1.5	15.74	5.4	0.220
GC-T2-08	10x35 15x35 20x35	1/2"x5/16"	08 B-2	2.2	21.42	7.4	0.295 0.460 0.630
GC-T2-10	10x40 15x40 20x40	5/8"x3/8"	10 B-2	2.6	25.79	9.2	0.320 0.540 0.770
GC-T2-12	15x45 20x45	3/4"x7/16"	12 B-2	2.4	30.76	11.3	0.620 0.845
GC-T2-16	15x65 20x65	1"17.02 mm	16 B-2	3.5	48.38	16.5	0.860 1.185

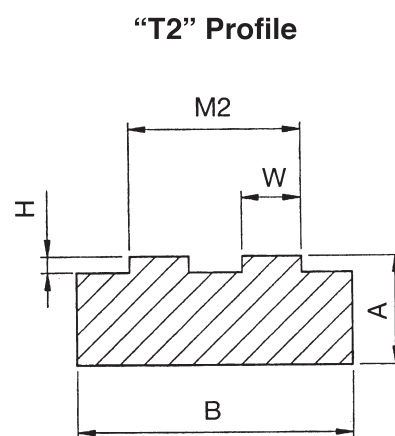

"T3" profile for triple chain		Chain	ISO	Guide dimensions			Weight Kg.m
AxB	H			M3	W		
GC-T3-06	10x35	3/8"x7/32"	06 B-3	1.5	25.88	5.4	0.770
GC-T3-08	10x45 15x45 20x45	1/2"x5/16"	08 B-3	2.2	35.24	7.4	0.820 1.045 1.270
GC-T3-10	10x55 15x55 20x55	5/8"x3/8"	10 B-3	2.6	42.38	9.2	0.850 1.125 1.400
GC-T3-12	15x60 20x60	3/4"x7/16"	12 B-3	2.4	50.22	11.3	0.855 1.155

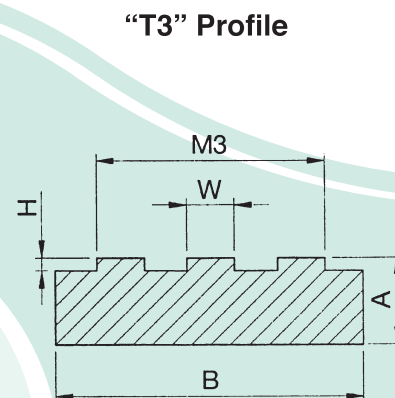

POLYETHYLENE CHAIN GUIDE RAILS

"E" profile for single chain		Chain	ISO	Guide dimensions				Weight Kg.m
AxB	H			M1	W	T		
GC-E-06	10x20	3/8"x7/32"	06 B-1	1.5	15	5.4	4.35	0.188
GC-E-08	15x25	1/2"x5/16"	08 B-1	2.2	16.3	7.4	1.6	0.352
GC-E-10	15x28	5/8"x3/8"	10 B-1	2.6	19.2	9.2	2.1	0.394
GC-E-12	20x38	3/4"x7/16"	12 B-1	2.4	28	11.3	11.11	0.564
GC-E-16	25x51	1"17.02 mm	16 B-1	3.5	41	16.5	16.48	0.830

"E" Profile

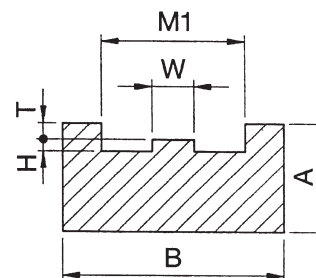

"K" profile for single chain		Chain	ISO	H	Guide dimensions					Weight Kg.m
AxB	D				E	F	G	C		
GC-K-06	25x20	3/8"x7/32"	06 B-1	10	6.8	4	5.6	8.7	9.3	0.430
GC-K-08	30x24	1/2"x5/16"	08 B-1	12.7	9	5	7.4	11.5	12.8	0.550
GC-K-10	35x30	5/8"x3/8"	10 B-1	14.8	10.7	6	9.3	13.5	15.4	0.830
GC-K-12	35x40	3/4"x7/16"	12 B-1	17.5	12.7	7	11.3	15.9	16.9	1.100
GC-K-16	45x40	1"17.02 mm	16 B-1	26.8	16.5	9	16.6	25.7	24.4	1.220

"K" Profile

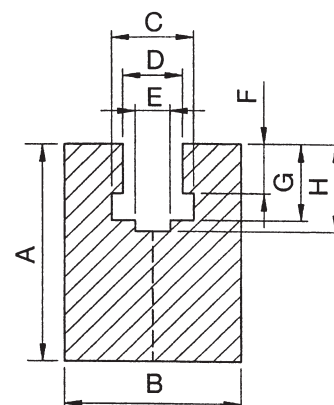

On request, can be supplied in two halves, at an extra cost

"U" profile for single chain		Chain	ISO	H	Guide dimensions			Weight Kg.m
AxB	E				F	C		
GC-U-06	15x20	3/8"x7/32"	06 B-1	4.2	4	2.8	9.2	0.260
GC-U-08	15x25	1/2"x5/16"	08 B-1	4.8	5	3.5	12.7	0.310
GC-U-10	15x25	5/8"x3/8"	10 B-1	5.1	6	3.6	15.2	0.300
GC-U-12	20x25	3/4"x7/16"	12 B-1	5.7	7	3.9	16.7	0.400

"U" Profile

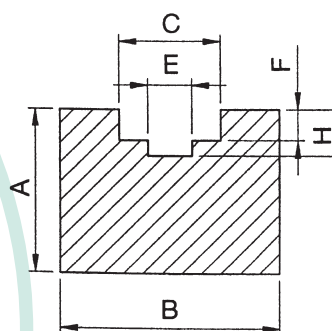

POLYETHYLENE CHAIN GUIDE RAILS

"KG" profile for single chain		Chain	ISO	Metal support	Guide dimensions					Weight Kg.m	
AxB	H				D	E	F	G	C		
GC-KG-08	22.5x27(*)	1/2"x5/16"	08 B-1	C10	13	8.7	5	7.4	11.5	12.8	1.295
GC-KG-10	22.5x27	5/8"x3/8"	10 B-1	C10	14.9	10.7	6	9.3	13.5	15.4	1.285
GC-KG-12	22.5x27	3/4"x7/16"	12 B-1	C10	17.5	12.3	7	11.3	15.9	16.9	1.275

On request, can be supplied in two halves, at an extra cost

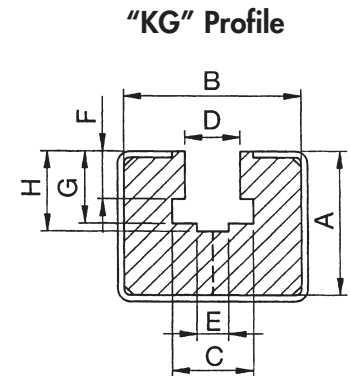

Designed for metal support

"CT" profile for single chain		Chain	ISO	Metal support	Guide dimensions				Weight Kg.m
AxB	H				T	W	B1		
GC-CT-08	15x20	1/2"x5/16"	08 B-1	C3	2.2	17	7.4	20	0.820
GC-CT-10	15x20	5/8"x3/8"	10 B-1	C3	2.6	17	9.2	20	0.830
GC-CT-12	15x20	3/4"x7/16"	12 B-1	C3	2.4	17	11.3	20	0.840
GC-CT-16	15x28(*)	1"x17.02 mm	16 B-1	C5	3.5	18	16.5	28	1.240

* On request

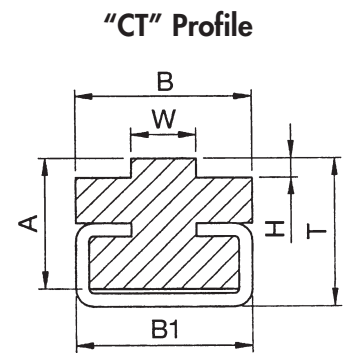

Designed for metal support

"CT2" profile for double chain		Chain	ISO	Metal support	Guide dimensions				Weight Kg.m
AxB	H				T	W	B2		
GC-CT2-06	15x15.7	3/8"x7/32"	06 B-2	C3	1.5	17	5.4	20	0.740
GC-CT2-08	15x21.4	1/2"x5/16"	08 B-2	C3	2.2	17	7.4	20	0.840
GC-CT2-10	15x25.9	5/8"x3/8"	10 B-2	C5	2.6	19	9.2	28	0.850
GC-CT2-12	15x30.7	3/4"x7/16"	12 B-2	C5	2.4	19	11.3	28	1.250
GC-CT2-16	20x48.3	1"x17.02 mm	16 B-2	C9	3.5	27	16.5	38	2.150

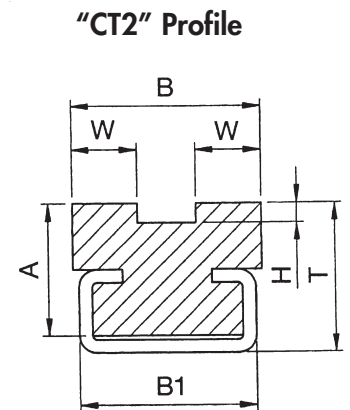

Designed for metal support

Metal supports	Standard length m.	Guide dimensions				Weight Kg.m	
		A	B	D	S		
C3	10x20(*)	2	10	20	10	1.3	0.480
C5	12x28 (*)	2	12	28	14	1.5	0.850
C9	18x38 (*)	2	18	38	22	1.5	1.500
C10	24x30 (*)	2	24	30	20	1.5	0.950

Metal Supports

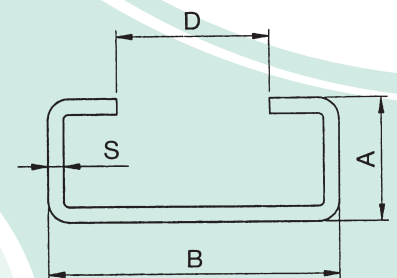

(*) Available in galvanised sheet metal - and in AISI 304 stainless steel

NB. Profiles based on the Customer's drawings are produced on request.

STRAIGHT SPUR GEARS AND RACKS

Straight gears and racks are the classical components for mechanical transmission of rotary and transverse movements between moving parts of machines.

This explains why these components are so widespread and are used to such a large extent in various sectors of general mechanics such that in practice it is impossible to find a rigid type power transfer drive chain which does not adopt these basic components.

However, the needs of industry are extremely complex as regards the performance required from the gear and the rack and reflect the typical operating conditions in terms of precision or resistance of final use for which the gear and the rack are designed. This is why proposing a product intended to meet any need expressed by industrial experience would be unthinkable.

CHIARAVALLI Trasmissioni has made a basic choice with this aspect in mind, deciding to offer industry a broad range of gears and racks for general use, combined in a standardised series, which is characterised by excellent quality.

The gears and racks produced using standardised C40 steel are manufactured adopting modular sizes in accordance with a reference profile that complies with DIN 3972 II and a full head radius. This ensures complete engagement at the base of the tooth with an obvious increase in the bending resistance.

The internal specifications that define the geometry of the tooth prescribe a marked "K" profile for the side surface, with a strict limitation of the profile errors to negative deviations. This has a positive influence on the level of noise of the toothed pair, since the engaging impacts to the teeth head are reduced.

The systematic use of latest generation CNC gear hobbing machines, special hobs designed for very high cutting speeds and specifically developed processing technologies, enable a general precision to be assured in compliance with DIN 3962 Standards and a degree of surface finish that is not readily achieved with operations using a hob gear cutting machine.

The working tolerance for tooth thickness has been chosen to comply with the "cd 25" Coupling Category in accordance with DIN 3967 Standards, which defines the position and the size of the tolerance range and therefore the coupling gap between the gears.

A processing tolerance equal to "js 8" for the centre distance is recommended in compliance with DIN 3964 Standards for normal operating conditions, which if adopted, enables us to assure a minimum working coupling gap of adequate size, while at the same time limiting the value of the maximum gap. Similar considerations apply in the case of the gear-rack coupling, since the latter is manufactured adopting the same coupling cate-

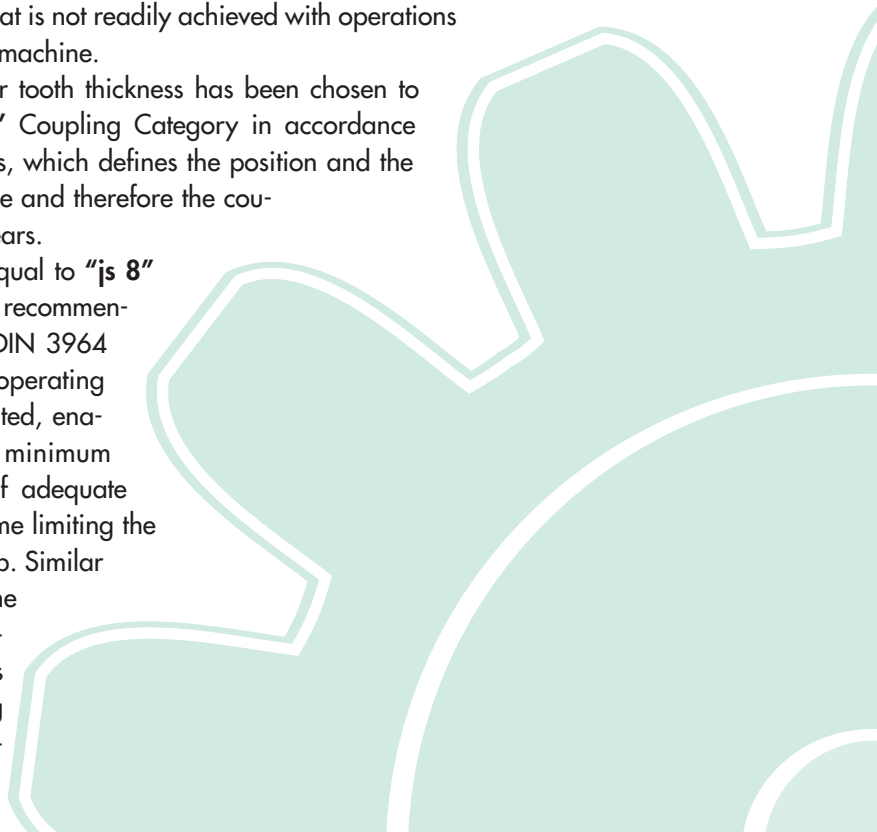

gory.

Our Technical Department is available and willing to recommend the most appropriate assembly tolerances to Customers who are interested, although we are also able to manufacture gears with coupling gaps that are larger or smaller compared with the standard value to meet specific needs.

We are able to manufacture our straight gears as illustrated in the catalogue with a lengthwise crowning of the teeth, at the request of customers. This solution is particularly useful if the user is unable to ensure a perfect alignment between the axles.

THE RANGE OF MACHINES USED, COMPRISING ALMOST ENTIRELY OF VERY MODERN MACHINES THAT HAVE CUTTING EDGE FEATURES AND DESIGN ENABLES OUR COMPANY TO PRODUCE GEARS BASED ON A DRAWING IN QUALITATIVE AT A VERY COMPETITIVE PRICE.

Our Technical Department is available to carry out a preliminary examination of any processing problems experienced by Customers and to prepare cost estimates.



STRAIGHT SPUR GEARS

HUBSIDE

Pressure angle 20°

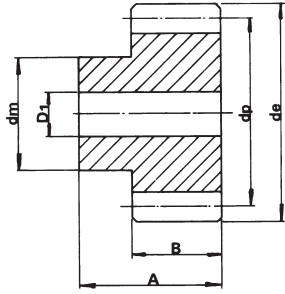

MATERIAL: C 45 – UNI 7845

TOOTH WIDTH "B" for:

MODULE 1	=	15 mm.
MODULE 1.5	=	17 mm.
MODULE 2	=	20 mm.
MODULE 2.5	=	25 mm.
MODULE 3	=	30 mm.
MODULE 4	=	40 mm.
MODULE 5	=	50 mm.
MODULE 6	=	60 mm.

TOTAL HEIGHT "A" for:

MODULE 1	=	25 mm.
MODULE 1.5	=	30 mm.
MODULE 2	=	35 mm.
MODULE 2.5	=	40 mm.
MODULE 3	=	50 mm.
MODULE 4	=	60 mm.
MODULE 5	=	75 mm.
MODULE 6	=	80 mm.

Z	MODULE 1				MODULE 1.5				MODULE 2				MODULE 2.5			
	d _e	d _p	d _m	D ₁	d _e	d _p	d _m	D ₁	d _e	d _p	d _m	D ₁	d _e	d _p	d _m	D ₁
12	14	12	9	5	21.0	18.0	14	8	28	24	18	10	35.0	30.0	22	10
13	15	13	10	5	22.5	19.5	14	8	30	26	19	10	37.5	32.5	25	10
14	16	14	10	5	24.0	21.0	18	8	32	28	20	10	40.0	35.0	28	10
15	17	15	12	6	25.5	22.5	18	8	34	30	22	10	42.5	37.5	30	10
16	18	16	13	6	27.0	24.0	20	8	36	32	24	10	45.0	40.0	32	12
17	19	17	14	8	28.5	25.5	20	8	38	34	25	10	47.5	42.5	35	12
18	20	18	15	8	30.0	27.0	20	8	40	36	25	10	50.0	45.0	35	12
19	21	19	15	8	31.5	28.5	20	8	42	38	25	10	52.5	47.5	35	12
20	22	20	16	8	33.0	30.0	25	8	44	40	30	10	55.0	50.0	40	14
21	23	21	16	8	34.5	31.5	25	10	46	42	30	12	57.5	52.5	40	14
22	24	22	18	8	36.0	33.0	25	10	48	44	30	12	60.0	55.0	45	14
23	25	23	18	8	37.5	34.5	25	10	50	46	30	12	62.5	57.5	45	14
24	26	24	20	8	39.0	36.0	25	10	52	48	35	12	65.0	60.0	45	14
25	27	25	20	8	40.5	37.5	25	10	54	50	35	12	67.5	62.5	50	14
26	28	26	20	8	42.0	39.0	30	12	56	52	40	12	70.0	65.0	50	14
27	29	27	20	8	43.5	40.5	30	12	58	54	40	12	72.5	67.5	50	14
28	30	28	20	8	45.0	42.0	30	12	60	56	40	12	75.0	70.0	50	14
29	31	29	20	8	46.5	43.5	30	12	62	58	40	14	77.5	72.5	50	14
30	32	30	20	8	48.0	45.0	30	12	64	60	40	14	80.0	75.0	55	16
31	33	31	25	10	49.5	46.5	35	12	66	62	45	14	82.5	77.5	55	16
32	34	32	25	10	51.0	48.0	35	12	68	64	45	14	85.0	80.0	55	16
33	35	33	25	10	52.5	49.5	35	12	70	66	45	14	87.5	82.5	55	16
34	36	34	25	10	54.0	51.0	35	12	72	68	45	14	90.0	85.0	55	16
35	37	35	25	10	55.5	52.5	35	12	74	70	45	14	92.5	87.5	60	16
36	38	36	25	10	57.0	54.0	35	12	76	72	45	14	95.0	90.0	60	16
37	39	37	25	10	58.5	55.5	40	12	78	74	50	14	97.5	92.5	60	16
38	40	38	25	10	60.0	57.0	40	12	80	76	50	14	100.0	95.0	60	16
39	41	39	25	10	61.5	58.5	40	12	82	78	50	14	102.5	97.5	60	16
40	42	40	25	10	63.0	60.0	40	12	84	80	50	14	105.0	100.0	70	20
41	43	41	30	10	64.5	61.5	50	14	86	82	60	16	107.5	102.5	70	20
42	44	42	30	10	66.0	63.0	50	14	88	84	60	16	110.0	105.0	70	20
43	45	43	30	10	67.5	64.5	50	14	90	86	60	16	112.5	107.5	70	20
44	46	44	30	10	69.0	66.0	50	14	92	88	60	16	115.0	110.0	70	20
45	47	45	30	10	70.5	67.5	50	14	94	90	60	16	117.5	112.5	70	20
46	48	46	30	10	72.0	69.0	50	14	96	92	60	16	120.0	115.0	70	20
47	49	47	30	10	73.5	70.5	50	14	98	94	60	16	122.5	117.5	80	20
48	50	48	30	10	75.0	72.0	50	14	100	96	70	16	125.0	120.0	80	20
49	51	49	30	10	76.5	73.5	50	14	102	98	70	16	127.5	122.5	80	20
50	52	50	30	12	78.0	75.0	50	14	104	100	70	16	130.0	125.0	80	20
51	53	51	40	12	79.5	76.5	60	15	106	102	70	20	132.5	127.5	90	20
52	54	52	40	12	81.0	78.0	60	15	108	104	70	20	135.0	130.0	90	20
53	55	53	40	12	82.5	79.5	60	15	110	106	70	20	137.5	132.5	90	20
54	56	54	40	12	84.0	81.0	60	15	112	108	70	20	140.0	135.0	90	20
55	57	55	40	12	85.5	82.5	60	15	114	110	70	20	142.5	137.5	90	20
56	58	56	40	12	87.0	84.0	60	15	116	112	70	20	145.0	140.0	100	20
57	59	57	40	12	88.5	85.5	60	15	118	114	70	20	147.5	142.5	100	20
58	60	58	40	12	90.0	87.0	60	15	120	116	70	20	150.0	145.0	100	20
59	61	59	40	12	91.5	88.5	60	15	122	118	70	20	152.5	147.5	100	20
60	62	60	40	12	93.0	90.0	60	15	124	120	70	20	155.0	150.0	100	20
61	63	61	50	12	94.5	91.5	70	20	126	122	80	20				
62	64	62	50	12	96.0	93.0	70	20	128	124	80	20				
63	65	63	50	12	97.5	94.5	70	20	130	126	80	20				
64	66	64	50	12	99.0	96.0	70	20	132	128	80	20				
65	67	65	50	12	100.5	97.5	70	20	134	130	80	20				
66	68	66	50	12	102.0	99.0	70	20	136	132	80	20				
67	69	67	50	12	103.5	100.5	70	20	138	134	80	20				
68	70	68	50	12	105.0	102.0	70	20	140	136	80	20				
69	71	69	50	12	106.5	103.5	70	20	142	138	80	20				
70	72	70	50	12	108.0	105.0	70	20	144	140	80	20				

STRAIGHT SPUR GEARS

HUBSIDE

Pressure angle 20°

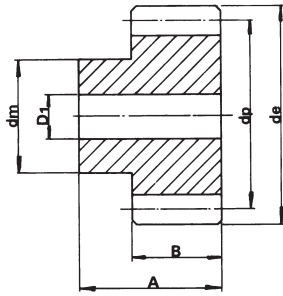

MATERIAL: C 45 – UNI 7845

TOOTH WIDTH "B" for:

MODULE 1	=	15 mm.
MODULE 1.5	=	17 mm.
MODULE 2	=	20 mm.
MODULE 2.5	=	25 mm.
MODULE 3	=	30 mm.
MODULE 4	=	40 mm.
MODULE 5	=	50 mm.
MODULE 6	=	60 mm.

TOTAL HEIGHT "A" for:

MODULE 1	=	25 mm.
MODULE 1.5	=	30 mm.
MODULE 2	=	35 mm.
MODULE 2.5	=	40 mm.
MODULE 3	=	50 mm.
MODULE 4	=	60 mm.
MODULE 5	=	75 mm.
MODULE 6	=	80 mm.

Z

12
13
14
15
16
17
18
19
20
21
22
23
24
25
26
27
28
29
30
31
32
33
34
35
36
37
38
39
40
41
42
43
44
45
46
47
48

	MODULE 3				MODULE 4				MODULE 5				MODULE 6			
	d _e	d _p	d _m	D ₁	d _e	d _p	d _m	D ₁	d _e	d _p	d _m	D ₁	d _e	d _p	d _m	D ₁
12	42	36	25	12	56	48	35	14	70	60	45	16	84	72	54	
13	45	39	25	12	60	52	40	14	75	65	50	16	90	78	60	
14	48	42	30	12	64	56	45	14	80	70	55	20				
15	51	45	35	12	68	60	45	14	85	75	60	20	102	90	70	
16	54	48	38	15	72	64	50	15	90	80	65	20	108	96	75	
17	57	51	42	15	76	68	50	15	95	85	70	20				
18	60	54	45	15	80	72	50	15	100	90	70	20	120	108	80	
19	63	57	45	15	84	76	60	15	105	95	70	20				
20	66	60	45	15	88	80	60	15	110	100	80	20	132	120	90	
21	69	63	45	15	92	84	70	20	115	105	80	20				
22	72	66	50	15	96	88	70	20	120	110	80	25				
23	75	69	50	15	100	92	75	20	125	115	90	25				
24	78	72	50	16	104	96	75	20	130	120	90	25	156	144	110	
25	81	75	60	16	108	100	75	20	135	125	90	25	162	150	110	
26	84	78	60	16	112	104	75	20	140	130	100	25				
27	87	81	60	16	116	108	75	20	145	135	100	25				
28	90	84	60	16	120	112	75	20	150	140	100	25				
29	93	87	60	16	124	116	75	20	155	145	100	25				
30	96	90	60	16	128	120	75	20	160	150	100	25				
31	99	93	70	20	132	124	80	20								
32	102	96	70	20	136	128	80	20								
33	105	99	70	20	140	132	80	20								
34	108	102	70	20	144	136	80	20								
35	111	105	70	20	148	140	80	20								
36	114	108	70	20	152	144	80	20								
37	117	111	80	20												
38	120	114	80	20												
39	123	117	80	20												
40	126	120	80	20												
41	129	123	90	20												
42	132	126	90	20												
43	135	129	90	20												
44	138	132	90	20												
45	141	135	90	20												
46	144	138	90	20												
47	147	141	90	20												
48	150	144	100	20												

STRAIGHT SPUR GEARS

HUBLESS

Pressure angle 20°

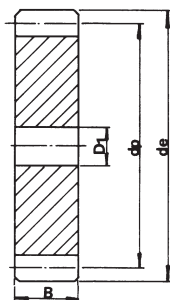

TOOTH WIDTH "B" for:

MODULE 1	=	15 mm.
MODULE 1.5	=	17 mm.
MODULE 2	=	20 mm.
MODULE 2.5	=	25 mm.
MODULE 3	=	30 mm.
MODULE 4	=	40 mm.
MODULE 5	=	50 mm.
MODULE 6	=	60 mm.

MATERIAL: C 45 – UNI 7845

Z

55
57
60
65
70
72
75
76
78
80
85
90
95
100
110
114
120
127

MODULE 1				MODULE 1.5				MODULE 2				MODULE 2.5			
d _e	d _p	d _m	D ₁	d _e	d _p	d _m	D ₁	d _e	d _p	d _m	D ₁	d _e	d _p	d _m	D ₁
												167.5	162.5		20
												180.0	175.0		20
74	72		12	111.0	108.0		20	148	144		20	185.0	180.0		20
77	75		12	115.5	112.5		20	154	150		20	192.5	187.5		20
78	76		12	117.0	114.0		20	156	152		20	195.0	190.0		20
82	80		12	123.0	120.0		20	164	160		20	205.0	200.0		25
87	85		12	130.5	127.5		20	174	170		20	217.5	212.5		25
92	90		12	138.0	135.0		20	184	180		20	230.0	225.0		25
97	95		12	145.5	142.5		20	194	190		20	242.5	237.5		25
102	100		12	153.0	150.0		20	204	200		20	255.0	250.0		25
112	110		12	168.0	165.0		20	224	220		20	280.0	275.0		25
116	114		12	174.0	171.0		20	232	228		20	290.0	285.0		25
122	120		12	183.0	180.0		20	244	240		20	305.0	300.0		25
129	127		12	193.5	190.5		20	258	254		20	322.5	317.5		25

Z

28
30
32
35
38
40
45
48
50
52
55
57
60
65
70
72
75
76
80
85
90
95
100
110
114
120
127

MODULE 3				MODULE 4				MODULE 5				MODULE 6			
d _e	d _p	d _m	D ₁	d _e	d _p	d _m	D ₁	d _e	d _p	d _m	D ₁	d _e	d _p	d _m	D ₁
												180	168		25
												192	180		25
								170	160		25	204	192		25
				160	152		25	185	175		25	222	210		25
				168	160		25	200	190		30	240	228		25
				188	180		25	210	200		30	252	240		25
				200	192		25	235	225		30				
				208	200		25	250	240		30				
156	150		25	208	200		25	260	250		30				
162	156		25	216	208		25	270	260		30				
171	165		25	228	220		25	285	275		30				
177	171		25	236	228		25	295	285		30				
186	180		25	248	240		25	310	300		30				
201	195		25	268	260		25	335	325		30				
216	210		25	288	280		25	360	350		30				
222	216		25												
231	225		25	308	300		25	385	375		30				
234	228		25	312	304		25	390	380		30				
246	240		25	328	320		25	410	400		30				
261	255		25	348	340		25	435	425		30				
276	270		25	368	360		25	460	450		30				
291	285		25	388	380		25	485	475		30				
306	300		25	408	400		25	510	500		30				
336	330		25	448	440		25	560	550		30				
348	342		25	464	456		25	580	570		30				
366	360		25												
387	381		25												

CAST IRON SPUR GEARS

		MATERIAL: G20 CAST IRON - UNI 5007						
Z	Module	2	2.5	3	3.5	4	4.5	5
	Bores D ₁	15	18	20	20	25	25	30
	Surface B	20	25	30	35	40	45	50
30	dp					120	135	150
	de					128	144	160
	dm					70	70	80
35	dp				122.5	140	157.5	175
	de				129.5	148	166.5	185
	dm				60	70	70	80
40	dp				140	160	180	200
	de				147	168	189	210
	dm				60	70	70	80
45	dp		112.5	135	157.5	180	202.5	
	de		117.5	141	163.5	188	211.5	
	dm		50	50	60	70	70	
50	dp	100	125		175	200	225	250
	de	104	130		182	208	234	260
	dm	40	50		60	70	70	80
60	dp			180				
	de			186				
	dm			50				

Gear till sold out

Spur Gears

Pressure angle 20°

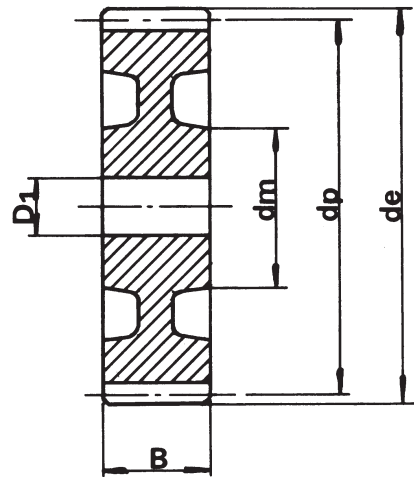

RACKS

		MATERIAL: C40 - DRAWN - STANDARDISED				
Module	Dimensions b x h		h ₀	L	kg.	
	b	h				
1	15	15	14	500	0.820	
	15	15	14	1000	1.640	
	15	15	14	2000	3.200	
1.5	17	17	15.5	500	1.000	
	17	17	15.5	1000	2.050	
	17	17	15.5	2000	4.000	
2	20	20	18	500	1.410	
	20	20	18	1000	2.750	
	20	20	18	2000	5.500	
2.5	25	25	22.5	500	2.100	
	25	25	22.5	1000	4.500	
	25	25	22.5	2000	9.000	
3	30	30	27	500	3.100	
	30	30	27	1000	6.500	
	30	30	27	2000	13.000	
4	30	30	26	500	3.050	
	30	30	26	1000	6.100	
	30	30	26	2000	12.500	
4	40	40	36	500	5.500	
	40	40	36	1000	11.000	
	40	40	36	2000	23.000	
5	50	50	45	500	8.300	
	50	50	45	1000	17.500	
	50	50	45	2000	35.000	
6	60	60	54	500	12.650	
	60	60	54	1000	25.500	
	60	60	54	2000	51.000	
10	80	80	70	2000	77.000	

Racks

Pressure angle 20°

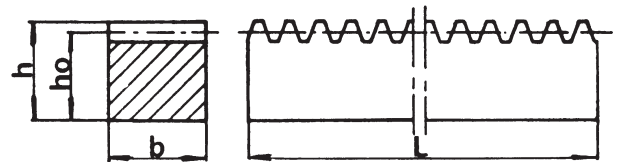

N.B. We manufacture racks from M7 to M16, on request.

BEVEL GEARS

The range of bevel gear showed in the catalogue is a selection structured according to transmission module and ratio, which is designed to meet the needs of general plant engineering and general mechanics to transmit motion among concurrent axes.

As such the range does not claim to guarantee particularly heavy-duty performance or to cater for ratio ranges that extend to cover every need.

The external configuration of the bevel gear complies with the sizing criteria as established by the DIN 3971 Standards, while the tooth geometry, corrected by displacing the profiles and by varying the taper, is a specific solution exclusive to **CHIARAVALLI Trasmissioni**.

This solution, provides special advantages since:

- the coupling conditions between the pinion and the ring gear are improved;
- a smoother motion transmission is assured;
- tooth resistance is increased;
- the undercut effect on the pinion is avoided, even in the case of high transmission ratios and pinions with a limited number of teeth.

Since these refer to a selection of gears intended to be used in a broad range of applications, **CHIARAVALLI Trasmissioni**, continuing a tradition that has now become firmly established, has defined a standardised tolerance category for the processing of the Company's range of bevel gear, which means that there is a controlled gearing gap between the wheels.

The requirements detailed in the DIN 3967 Standards adapted to the virtual teeth profile of the bevel gear and the recommendations of the DIN 3964 Standards to calculate the corresponding axial displacements for the assembly distances have been used for this purpose.

We are therefore in a position to provide the end user precise information regarding the tolerances to be adopted to define shaving adjustments to a given clearance, in accordance with the values detailed in the dimensional tables.

All the bevel gears manufactured by **CHIARAVALLI Trasmissioni** will be produced in accordance with the profile envelope procedure on modern gear cutting machines, which enables **CHIARAVALLI Trasmissioni** to ensure a satisfactory quality level thanks to the systematic checking of processing tolerances.

For this technological sector too, the equipment and the range of machines available to **CHIARAVALLI Trasmissioni** enables the Company to produce bevel gears based on a drawing and in accordance with the Customer's specifications.

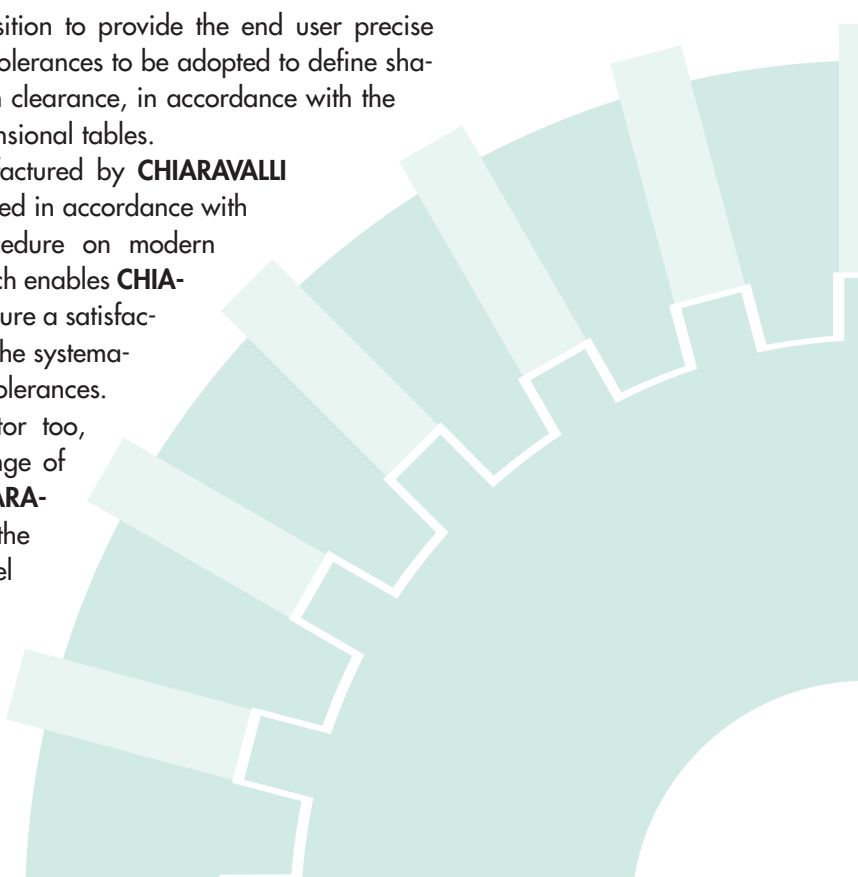

STRAIGHT TEETH BEVEL GEARS

MATERIAL: C 43 - UNI 7847

M	Z	d _p	d _e	F	A	d _m	D ₁	L	V	S	L _m
1.5	16	24.0	26.12	6	18.9	20.3	8		7.10		12
	20	30.0	32.12	10	20	22	10	18	7.40	2	8.5
	25	37.5	39.62	10	23	28	10	21	11.09	2	12
	30	45.0	47.12	12	25	30	12	22.5	13.35	2.5	12
2	16	32.0	34.83	8	23.5	25.3	8		9.50		14
	20	40.0	42.83	12	25	32	10	22	10.78	3	12
	25	50.0	52.82	14	28	40	12	25	14.28	3	12.3
	30	60.0	62.83	16	30	50	12	27	17.78	3	12.8
2.5	16	40.0	43.53	10	28.1	30.3	12		11.90		15
	20	50.0	53.53	12	30.5	40	12	27	15.43	3.5	16
	25	62.5	66.00	15	33.5	50	15	30	19.48	3.5	16
	30	75.0	78.53	18	35.5	55	15	32	23.63	3.5	16
3	16	48.0	52.25	12	31.7	40.3	12		14.30		18
	20	60.0	64.24	18	35	45	15	31	16.00	4	13.6
	25	75.0	79.24	20	38	55	15	34	22.00	4	16
	30	90.0	94.24	22	40	60	20	36	28.00	4	17
3.5	16	56.0	60.95	14	36.4	45.3	16		16.60		20
	20	70.0	74.95	22	40.5	55	15	36	18.13	4.5	17
	25	87.5	92.45	26	43.5	65	20	39	23.97	4.5	18
	30	105.0	109.95	30	48	70	20	43.5	30.02	4.5	19
4	16	64.0	69.65	15	44.3	50.3	16		19.70		25
	20	80.0	85.65	25	43	60	18	38	20.74	5	18
	25	100.0	105.65	28	45	70	20	40	28.50	5	18
	30	120.0	125.65	32	48	80	20	43	35.67	5	16
4.5	16	72.0	78.38	17.5	46.3	55.3	20		21.70		25
	20	90.0	96.38	28	48	65	20	42	23.41	6	18
	25	112.5	118.80	32	50	75	20	44	31.76	6	18
	30	135.0	141.38	35	53	90	20	47	40.82	6	17
5	16	80.0	87.07	18	48.9	60.3	20		25.10		25
	20	100.0	107.07	30	50.5	70	20	44	26.86	6.5	18.5
	25	125.0	132.07	34	53.5	90	20	47	36.36	6.5	18
	30	150.0	157.07	38	56.5	110	20	50	45.97	6.5	18

Normal axis Bevel Gears

Pressure angle: 20°
in compliance with UNI 6588

Ratio - 1:1

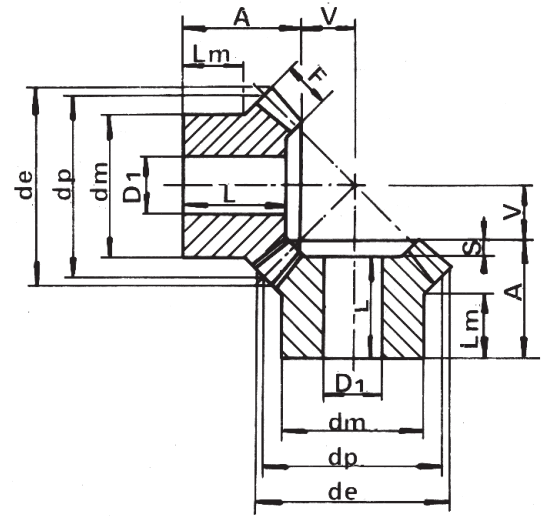

MATERIAL: C 43 - UNI 7847

M	Z	d _p	d _e	F	A	d _m	D ₁	L	V	S	L _m
1.5	16	24	26.68	8	19.5	21	10	18	16.33	1.5	11.3
	32	48	49.34	8	20.0	32	12	17	7.45	3	10
2	16	32	35.57	10	23.0	26	10	21	22.41	2	11.9
	32	64	65.78	10	25.0	40	12	21	10.21	4	10
2.5	16	40	44.47	12	27.5	34	12	25	28.38	2.5	14.4
	32	80	82.23	12	25.0	50	15	20	12.97	5	10
3	16	48	53.36	15	28.0	40	15	25	33.64	3	11.6
	32	96	98.68	15	30.0	60	15	24	15.31	6	10
3.5	16	56	62.26	18	33.5	48	15	30	38.83	3.5	14.4
	32	112	115.12	18	31.0	70	20	24	17.77	7	10
4	16	64	71.15	20	36.0	50	15	32	44.81	4	13.4
	32	128	131.57	20	32.0	80	20	24	20.42	8	10
4.5	16	72	80.05	22	39.5	60	20	35	51.00	4.5	15.4
	32	144	148.00	22	36.0	90	20	27	23.21	9	10
5	16	80	88.94	25	50.0	60	20	45	56.06	5	21.1
	32	160	164.46	25	38.0	100	20	28	25.52	10	10

Normal axis Bevel Gears

Pressure angle: 20°
in compliance with UNI 6588

Ratio - 1:2

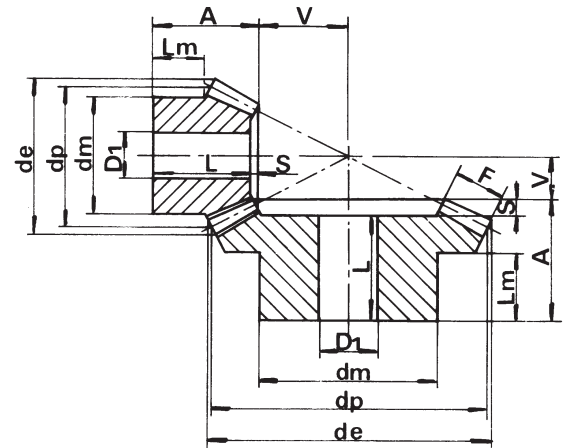

STRAIGHT TEETH BEVEL GEARS

MATERIAL: C 43 – UNI 7847

M	Z	d _p	d _e	F	A	d _m	D ₁	L	V	S	L _m
1.5	16	24	26.82	12	24	20	10	23	24.42	1	11.7
	48	72	72.95	12	20	50	12	17	7.27	3	10
2	16	32	35.80	15	28.5	26	12	27	33.26	1.5	12.4
	48	96	97.26	15	23	60	15	19	9.90	4	10
2.5	16	40	44.74	18	32	32	12	30	42.41	1.5	13
	48	120	121.58	18	26	70	20	21	12.60	5	10
3	16	48	53.69	18	32	40	15	30	54.25	2	12.1
	48	144	145.90	18	29	80	20	23	16.20	6	10
3.5	16	56	62.64	22	38	48	15	35.5	62.29	2.5	15
	48	168	170.21	22	31	90	20	24	18.48	7	10
4	16	64	71.59	25	41.5	55	20	38.5	71.23	3	15.2
	48	192	194.53	25	33	100	20	25	21.20	8	10
4.5	16	72	80.53	28	53	60	20	50	80.27	3	23.4
	48	216	218.84	28	49	100	20	40	23.93	9	18
5	16	80	89.48	35	60	60	20	57	85.61	3	22.5
	48	240	243.16	35	50	150	20	40	25.45	10	20

Normal axis Bevel Gears

Pressure angle: 20°
in compliance with UNI 6588

Ratio – 1:3

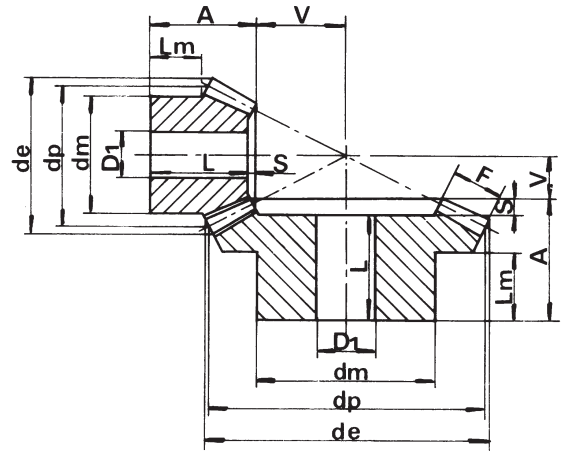

MATERIAL: C 43 – UNI 7847

M	Z	d _p	d _e	F	A	d _m	D ₁	L	V	S	L _m
1.5	16	24	26.91	12	25	18	10	24	36.02	1	12.2
	64	96	96.73	12	22	70	15	19	8.53	3	10
2	16	32	35.88	15	24	25	12	23	49.07	1	8.2
	64	128	128.97	15	24	80	20	20	11.79	4	10
2.5	16	40	44.85	18	30.5	30	12	29	61.99	1.5	11.7
	64	160	161.21	18	29	90	20	24	13.77	5	10
3	16	48	53.82	22	34	40	15	32	74.05	2	11
	64	192	193.45	22	30	100	20	24	16.41	6	10
3.5	16	56	62.80	25	45	48	15	43	87.13	2	19.1
	64	224	225.70	25	50	100	20	43	19.32	7	22
4	16	64	71.76	30	50	50	20	48	98.21	2	18.5
	64	256	257.94	30	50	120	20	42	21.72	8	20
4.5	16	72	80.73	32	53	55	20	50.5	112.08	2.5	19
	64	288	290.18	32	53	130	20	44	24.83	9	23
5	16	80	89.70	35	58	60	20	55.5	125.06	2.5	20.6
	64	320	322.42	35	58	150	20	48	27.65	10	25

Normal axis Bevel Gears

Pressure angle: 20°
in compliance with UNI 6588

Ratio – 1:4

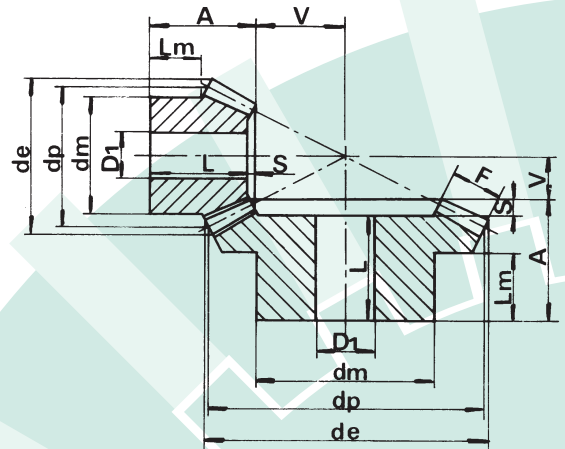

STRAIGHT TEETH BEVEL GEARS SPECIAL EXECUTION

Normal axis Bevel Gears

Pressure angle: 20°

Gleason System

Ratio - 1:1

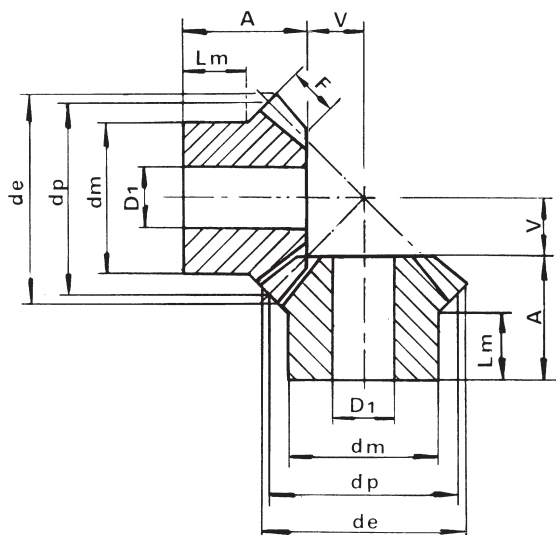

MATERIAL: C 43 - UNI 7847

M	Z	d _p	d _e	F	A	d _m	D ₁	V	L _m
1	16	16.0	17.4	4	11.2	13.3	4	4.80	6.5
	19	19.0	20.4	4	11.8	15.3	4	6.20	6.5
	22	22.0	23.4	4.7	12.8	16.3	5	7.20	6.5
	26	26.0	27.4	5.5	13.3	20.3	5	8.70	7
	30	30.0	31.4	6.4	16	20.3	5	10.00	8
1.5	16	24.0	26.1	6	18.9	20.3	8	7.10	12
	19	28.5	30.6	7	21.3	20.3	8	8.70	12
	22	33.0	35.1	7.5	22.5	25.3	8	10.50	12
	26	39.0	41.1	8.5	23.2	28.3	8	12.80	12
	30	45.0	47.1	10	27.2	30.3	12	14.80	12
2	16	32.0	34.8	8	23.5	25.3	8	9.50	14
	19	38.0	40.8	9	24.2	25.3	8	11.80	12
	22	44.0	46.8	10	27.9	30.3	12	14.10	14
	26	52.0	54.8	12	31.4	35.3	12	16.60	14
	30	60.0	62.8	13	34.1	40.3	14	19.90	17
2.5	16	40.0	43.5	10	28.1	30.3	12	11.90	15
	19	47.5	51.0	11	27.1	35.3	12	14.90	13
	22	55.0	58.5	12	30.1	45.3	16	17.90	16
	26	65.0	68.5	15	33.2	45.3	16	20.80	16
	30	75.0	78.5	16	39	50.3	16	25.00	20
3	16	48.0	52.5	12	31.7	40.3	12	14.30	18
	19	57.0	61.2	13	36	40.3	14	18.00	17
	22	66.0	70.2	15	36.9	50.3	16	21.10	17
	26	78.0	82.2	17	38.4	50.3	16	25.60	18
	30	90.0	94.2	19	43.8	60.3	20	30.20	22
3.5	16	56.0	60.9	14	36.4	45.3	16	16.60	20
	19	66.5	71.5	15	37.8	50.3	18	21.00	19
	22	77.0	81.9	17	39.1	55.3	20	24.90	18
	26	91.0	96.0	20	43.35	62.3	20	29.70	20
	30	105.0	110.0	23	47.1	70.3	20	34.90	22
4	16	64.0	69.7	15	44.3	50.3	16	19.70	25
	19	76.0	81.7	18	44.4	55.3	20	23.60	22
	22	88.0	93.7	20	45.9	60.3	20	28.10	22
	26	104.0	109.7	25	48	70.3	20	34.00	22
	30	120.0	125.7	26	54.2	80.3	20	39.80	25
4.5	16	72.0	78.4	17.5	46.3	55.3	20	21.70	25
	19	85.5	91.8	20	49	62.3	20	26.57	25
	22	99.0	105.3	22	50.1	70.3	20	31.90	25
	26	117.0	123.0	25	54.7	75.3	20	38.60	26
	30	135.0	141.4	29	60	80.3	20	45.00	28
5	16	80.0	87.1	18	48.9	60.3	20	25.10	25
	19	95.0	102.1	22	52.2	60.3	20	29.80	25
	22	110.0	117.1	24	58.2	80.3	20	35.80	30
	26	130.0	137.1	29	62.7	80.3	20	42.30	30
	30	150.0	157.1	32	68.9	80.3	20	50.10	35

STRAIGHT TEETH BEVEL GEARS

MATERIAL: C 43 – UNI 7847

M	Z	d _p	d _e	F	A	d _m	D ₁	L	V	S	L _m
1	16	16	18.1	4.3	12	13.3	4		8		7
	24	24	24.8	4.3	14.8	20.3	5	13.3	5.2	1.5	9.3
1.5	16	24	27.1	8	20.3	20.3	8		10.7		11.8
	24	36	37.2	8	24.9	28.3	8	22.7	7.1	2.2	16
2	16	32	36.2	10	25.2	25.3	8		14.8		13.8
	24	48	49.7	10	27.2	32.3	8	24.7	9.8	2.5	16
2.5	16	40	45.2	13	30.8	32.3	12		18.2		16.4
	24	60	62.1	13	34	45.3	14	30.8	12	3.2	20
3	16	48	54.3	14.5	32.4	40.3	12		22.6		16.4
	24	72	74.5	14.5	36.2	55.3	16	32	14.8	4.2	20
3.5	16	56	63.3	18	40.4	45.3	16		25.6		20.4
	24	84	86.9	18	44.2	55.3	20	40	16.8	4.2	25
4	16	64	72.4	18	46.8	50.3	16		31.2		25.4
	24	96	99.3	18	45.5	60.3	20	40	20.5	5.5	25
4.5	16	72	81.4	20	47.6	60.3	20		35.4		25.1
	24	108	111.7	20	57.8	80.3	20	51.3	23.2	6.5	35
5	16	80	90.5	24	54.1	60.3	20		37.9		25.4
	24	120	124.1	24	61.1	80.3	20	54.5	24.9	6.6	35

Normal axis Bevel Gears

Pressure angle: 20°

Gleason System

Ratio – 1:1.5

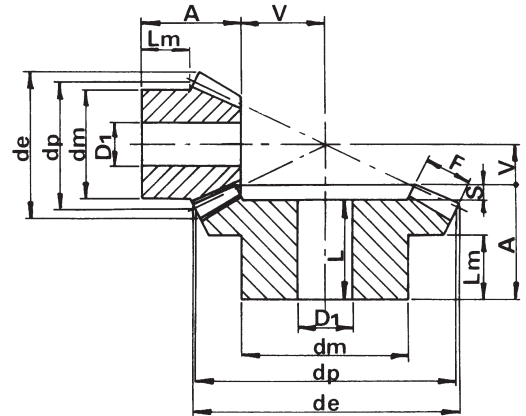

MATERIAL: C 43 – UNI 7847

M	Z	d _p	d _e	F	A	d _m	D ₁	L	V	S	L _m
1	15	15.0	17.4	5	11.9	13.3	4		10.1		6.5
	30	30.0	30.6	5	15.1	20.3	5	13.7	4.9	1.4	9
1.5	15	22.5	26.1	9	21.1	19.3	8		13.9		11.9
	30	45.0	45.9	9	25.2	32.3	8	23	6.8	2.2	16
2	15	30.0	34.8	11.5	26	25.3	8		19.0		14.1
	30	60.0	61.2	11.5	29.8	40.3	14	26.8	9.2	3	18
2.5	15	37.5	43.5	15	31.8	32.3	12		23.2		16.2
	30	75.0	76.5	15	33.7	45.3	16	30	11.3	3.7	20
3	15	45.0	52.2	17	37.3	40.3	12		28.7		19.9
	30	90.0	91.8	17	42.1	55.3	16	38	13.9	4.1	25
3.5	15	52.5	60.9	20.5	46.1	45.3	16		32.9		24.7
	30	105.0	107.1	20.5	45	60.3	20	40	16.0	5	25
4	15	60.0	69.6	22.5	48.6	50.3	20		38.4		24.6
	30	120.0	122.3	22.5	57.3	80.3	20	51.9	18.7	5.4	35
4.5	15	67.5	78.3	26	51.4	60.3	20		42.6		24.7
	30	135.0	137.6	26	60.3	80.3	20	54.3	20.7	6	35
5	15	75.0	87	30	57.6	60.3	20		46.4		25.3
	30	150.0	152.9	30	62.5	80.3	20	56	22.5	6.5	35

Normal axis Bevel Gears

Pressure angle: 20°

Gleason System

Ratio – 1:2

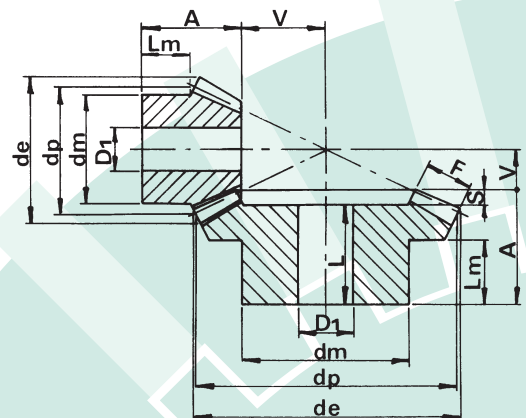

STRAIGHT TEETH BEVEL GEARS

MATERIAL: C 43 – UNI 7847

M	Z	d _p	d _e	F	A	d _m	D ₁	L	V	S	L _m
1	16	16	18.6	6.5	14.4	13.3	4		13.6		7.4
	40	40	40.4	6.5	14.8	25.3	8	13	5.2	1.8	9
1.5	16	24	27.9	11.5	24.2	20.3	8		18.8		12.3
	40	60	60.7	11.5	27.8	40.3	14	25.5	7.2	2.3	18
2	16	32	37.2	15	29.6	25.3	8		25.4		13.7
	40	80	80.9	15	32.4	45.3	16	29	9.6	3.4	20
2.5	16	40	46.4	19	38.4	32.3	12		31.6		18.5
	40	100	101.1	19	39.8	55.3	16	35.9	12.2	3.9	25
3	16	48	55.7	21.5	41.9	40.3	16		39.1		19.6
	40	120	121.4	21.5	47.9	60.3	20	44	15.1	3.9	30
3.5	16	56	65.0	22.6	49.1	45.3	20		47.9		25
	40	140	141.6	22.6	54.6	80.3	20	50	18.4	4.6	35
4	16	64	74.3	26	52.5	55.3	20		54.5		25.3
	40	170	161.8	26	57.0	80.3	20	50.5	21.0	6.5	35
4.5	16	72	83.6	30	56.3	60.3	20		60.7		24.6
	40	180	182.1	30	59.7	80.3	20	53	23.3	6.7	35
5	16	80	92.9	32	65.4	60.3	20		68.6		30.1
	40	200	202.3	32	65.7	90.3	20	58.3	26.3	7.4	40

Normal axis Bevel Gears

Pressure angle: 20°

Gleason System

Ratio – 1:2.5

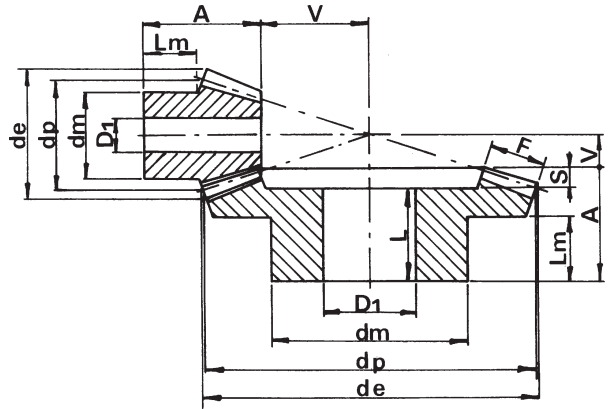

Bevel gears available till sold out

MATERIAL: C 43 – UNI 7847

M	Z	d _p	d _e	F	A	d _m	D ₁	L	V	S	L _m
1	15	15	17.7	7.1	16.6	13.3	4		15.4		9.2
	45	45	45.3	7.1	17.1	25.3	8	15.2	4.9	1.9	10
1.5	15	22.5	26.5	10.5	22.6	19.3	8		23.4		11.7
	45	67.5	68.1	10.5	29.6	45.3	14	27.2	7.4	2.4	20
2	15	30	35.4	14	28.9	25.3	8		31.1		14.2
	45	90	90.8	14	32.1	45.3	16	28.4	9.9	3.7	20
2.5	15	37.5	44.2	18	34.6	32.3	12		38.4		15.9
	45	112.5	113.4	18	39.7	60.3	20	35.3	12.3	4.4	25
3	15	45	53.0	21	41.3	40.3	16		46.7		19.7
	45	135	136.1	21	47.2	60.3	20	42	14.8	5.2	30
3.5	15	52.5	61.9	23.5	49.6	45.3	20		55.4		25
	45	157.5	158.8	23.5	54.4	80.3	20	48.6	17.6	5.8	35
4	15	60	70.7	27.5	54.3	50.3	20		62.7		25.4
	45	180	181.5	27.5	57	80.3	20	50.5	20	6.5	35
4.5	15	67.5	79.5	28.5	55.2	55.3	20		72.8		24.8
	45	202.5	204.2	28.5	63.9	90.3	20	57	23.1	6.9	40
5	15	75	88.4	33	65.3	60.3	20		79.7		30
	45	225	226.9	33	66.7	90.3	20	59.2	25.3	7.5	40

Normal axis Bevel Gears

Pressure angle: 20°

Gleason System

Ratio – 1:3

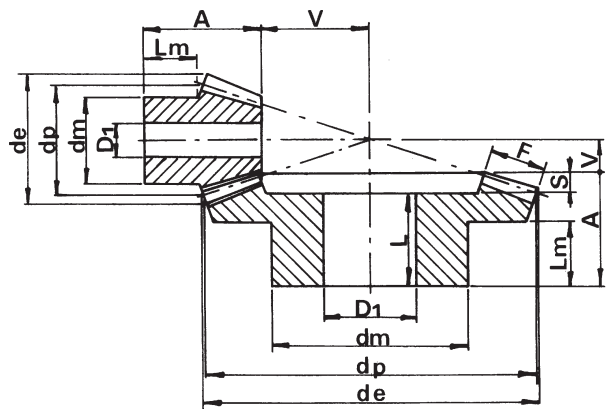

STRAIGHT TEETH BEVEL GEARS

MATERIAL: C 43 – UNI 7847

M	Z	d _p	d _e	F	A	d _m	D ₁	L	V	S	L _m
1	16	16	18.7	8.7	16.6	13.3	4		19.4		7.6
	56	56	56.3	8.7	16.7	30.3	8	14.2	5.3	2.5	10
1.5	16	24	28.1	12	24	20.3	8		30		11.5
	56	84	84.5	12	34.8	45.3	14	32	8.2	2.8	25
2	16	32	37.5	16	30.9	25.3	8		40.1		14.1
	56	112	112.6	16	37.1	55.3	16	33.3	10.9	3.8	25
2.5	16	40	46.8	20	38.9	32.3	14		50.1		17.9
	56	140	140.8	20	44.4	60.3	20	40	13.6	4.4	30
3	16	48	56.2	24	49.9	40.3	16		60.1		24.9
	56	168	169	24	52.7	80.3	20	47.5	16.3	5.2	35
3.5	16	56	65.6	25	52	25.5	20		73		25.5
	56	196	197.1	25	55.1	80.3	20	49.1	19.9	6	35

Normal axis Bevel Gears

Pressure angle: 20°

Gleason System

Ratio – 1:3.5

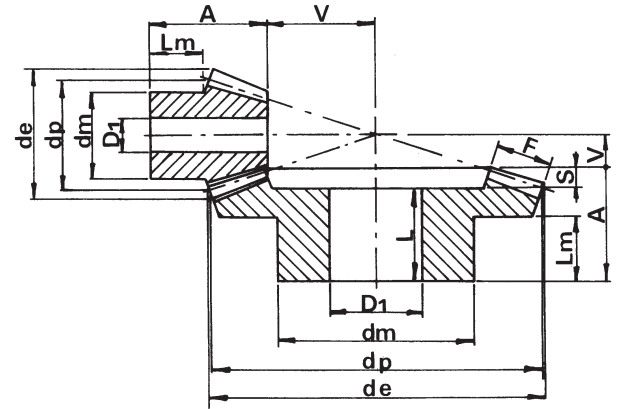

Bevel gears available till sold out

MATERIAL: C 43 – UNI 7847

M	Z	d _p	d _e	F	A	d _m	D ₁	L	V	S	L _m
1	15	15.0	17.80	9.3	17.2	13.3	4		20.8		7.7
	60	60	60.30	9.3	17.1	30.3	8	15.2	4.9	1.9	10
1.5	15	22.5	26.70	11	23	20.3	8		34.0		11.7
	60	90	90.40	11	34	50.3	16	31.2	8.0	2.8	25
2	15	30	35.60	16	31	25.3	8		44.0		14.4
	60	120	120.60	16	37.6	60.3	16	34.2	10.4	3.4	25
2.5	15	37.5	44.50	19	38.1	32.3	14		55.9		18.4
	60	150	150.70	19	44.8	60.3	20	40	13.2	4.8	30
3	15	45	53.30	23	48.1	40.3	16		66.9		24.5
	60	180.0	180.80	23	53.2	80.3	20	48.2	15.8	5	35
3.5	15	52.5	62.20	26	52.1	45.3	20		78.9		25.1
	60	210	211.00	26	60.4	90.3	20	54.4	18.6	6	40
4	15	60	71.10	30	55.1	50.3	20		89.9		23
	60	240	241.10	30	60.8	90.3	20	53	21.2	7.8	40
4.5	15	67.5	79.97	32	57	52.3	20		102.9		23
	60	270	271.24	32	62	90.3	20	53.5	24.3	8.5	40
5	15	75	88.80	34	62	55.3	20		115.7		25
	60	300.0	301.30	34	65	90.3	20	55	27.0	10	40

Normal axis Bevel Gears

Pressure angle: 20°

Gleason System

Ratio – 1:4

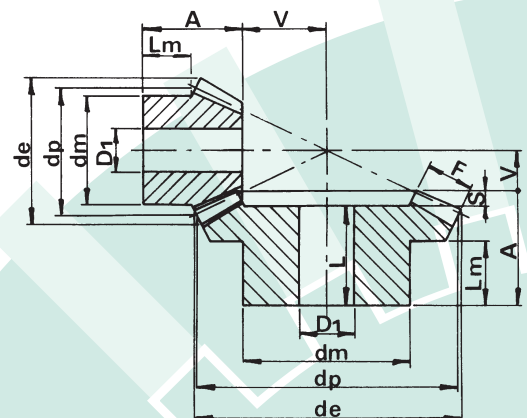

BEVEL GEARS FOR TRANSMISSIONS BETWEEN ORTHOGONAL AXES

DECLARATION OF INTENT

The **change project** of this range of bevel gears has been developed with the intention of standardising the execution of this product and reducing the number of articles carried in the catalogue.

The key aspects of the project to which we intend to draw the attention of users can be specified as follows:

- Deletion of the "special" execution bevel gears and adoption of a single execution with harmonised sizing criteria.
- Adoption of the DIN 3971 Standards to size the tooth profile and the external body of the gears.
- Systematic correction of teeth by profile displacement to eliminate the undercut effect on the pinions, to improve the slip and the specific pressure and to obtain a tooth that is better able to withstand bending stresses.
- Selection of a standardised external configuration in terms of the front embedding on the bevel gears which will be implemented only from a given module.
- Generalised increase of the surface width to achieve higher load-bearing capacities.
- Selection of the ratios and the number of teeth based solely on the normal number of the R20 range in compliance with the UNI 2016 and the DIN 323 Standards, as well as the ISO R3 and ISO R17 recommendations, with the following progressions:

Ratio	1:1 = 16 - 18 - 20 - 22 - 25 - 28 - 32
	1:2 = 16/32
	1:3 = 16/48
	1:4 = 16/64

This initiative comes within the framework of a broader critical review of the Company's products, and CHIARAVALLI Trasmissioni spa intends to implement a form of technical collaboration with customers and will take due consideration of technical advice, suggestions and assessments for which CHIARAVALLI Trasmissioni spa thanks you in advance.

BEVEL GEARS FOR TRANSMISSIONS BETWEEN ORTHOGONAL AXES

Straight teeth Bevel Gears sized in compliance with DIN 3971

Corrected toothing by profile displacement and length-wise crowning of the tooth

Pressure angle: 20°

Gear ratio = 1:1

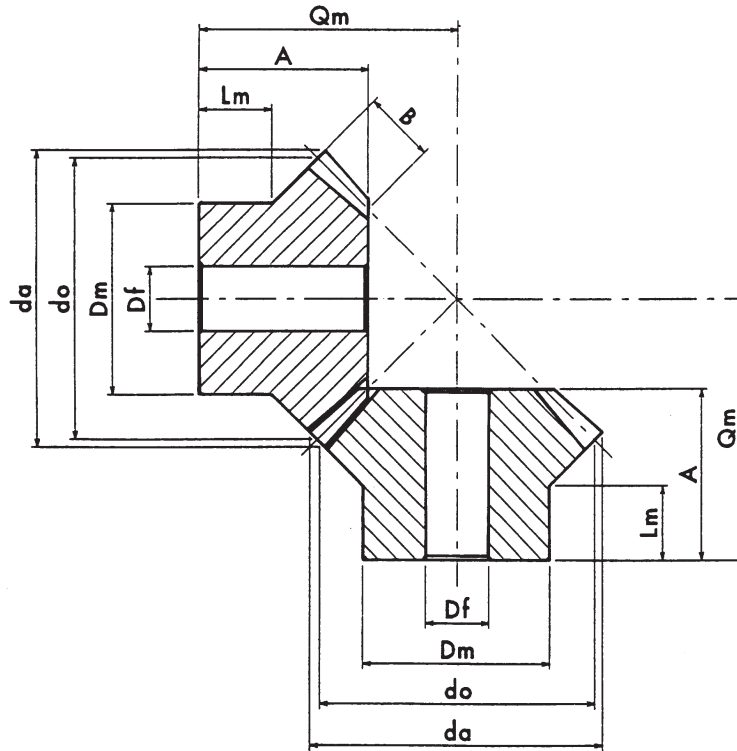

MATERIAL: C 43 STEEL – UNI 7847

M	z	d _o	d _a	D _m	D _f	B	L _m	A	Q _m	Tolerance Q _m	
										min.	max
1	16	16	17	12	4	4	7	12.28	17	-0.020	0.020
	18	18	19	14	4	4	7	12.31	18	-0.020	0.020
	20	20	21	16	4	4.5	8	13.66	20	-0.020	0.020
	22	22	23	18	5	5	8	14.01	21	-0.020	0.020
	25	25	26	20	5	5.5	8	14.87	23	-0.020	0.020
	28	28	29	20	5	6	9	17.74	27	-0.020	0.020
	32	32	33	22	5	7	12	20.44	31	-0.020	0.020
1.5	16	24	25.5	18	6	5.5	10	17.60	25	-0.020	0.020
	18	27	28.5	20	8	6	12	20.47	29	-0.020	0.020
	20	30	31.5	22	8	6.5	12	21.33	31	-0.020	0.020
	22	33	34.5	24	8	7	12	22.19	33	-0.020	0.020
	25	37.5	39	28	8	8	13.5	24.64	37	-0.030	0.030
	28	42	43.5	30	12	9	14	27.10	41	-0.030	0.030
2	32	48	49.5	36	12	10	16	29.82	46	-0.030	0.030
	16	32	34	24	8	7	14	23.92	34	-0.020	0.020
	18	36	38	28	8	7.5	15	25.30	37	-0.030	0.030
	20	40	42	28	8	8	15	24.67	38	-0.030	0.030
	22	44	46	30	12	9	16	28.37	43	-0.030	0.030
	25	50	52	32	12	11	16	29.75	46	-0.030	0.030
	28	56	58	36	12	12	18	34.47	53	-0.030	0.030
2.5	32	64	66	40	14	13	20	38.20	60	-0.030	0.030
	16	40	43	30	12	8	14	25.92	39	-0.030	0.030
	18	45	48	34	12	9	15	28.13	43	-0.030	0.030
	20	50	53	35	12	10	18	32.34	49	-0.030	0.030
	22	55	58	42	14	11	18	33.55	52	-0.030	0.030
	25	62.5	65.5	46	14	12	20	34.50	56	-0.030	0.030
	28	70	73	48	14	14	22	40.17	64	-0.030	0.030
32	80	83	52	16	16	22	43.58	71	-0.030	0.030	

BEVEL GEARS FOR TRANSMISSIONS BETWEEN ORTHOGONAL AXES

Straight teeth Bevel Gears sized in compliance with DIN 3971

Corrected toothing by profile displacement and length-wise crowning of the tooth

Pressure angle: 20°

Gear ratio = 1:1

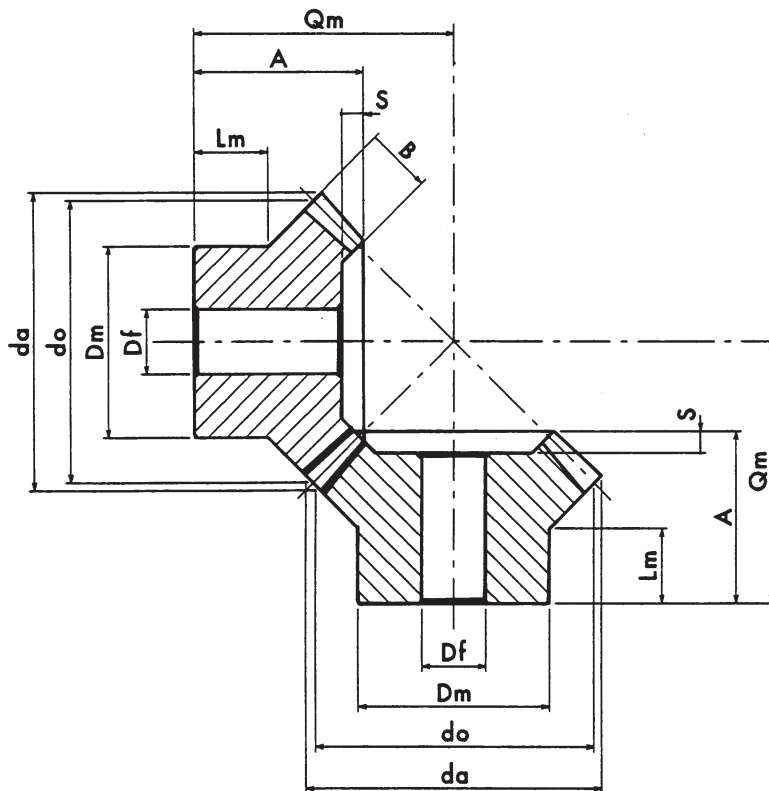

MATERIAL: C 43 STEEL – UNI 7847

M	z	d _o	d _a	D _m	D _f	B	L _m	A	S	Q _m	Tolerance Q _m	
											min.	max
3	16	48	51.5	36	12	12	16	31.85	4	46	-0.030	0.030
	18	54	57.5	40	14	14	18	36.24	4	52	-0.030	0.030
	20	60	63.5	45	14	16	20	37.63	4	55	-0.030	0.030
	22	66	69.5	50	16	16	20	37.70	4	58	-0.030	0.030
	25	75	78.5	50	16	16	24	45.29	4	70	-0.030	0.030
	28	84	87.5	55	16	18	25	48.21	4	76	-0.030	0.030
	32	96	99.5	66	16	20	25	49.63	4	82	-0.040	0.040
3.5	16	56	60	40	14	14	18	35.50	5	52	-0.030	0.030
	18	63	67	45	14	16	18	38.40	5	57	-0.030	0.030
	20	70	74	50	16	18	22	44.30	5	65	-0.030	0.030
	22	77	81	55	16	20	22	46.21	5	69	-0.030	0.030
	25	87.5	91.5	60	16	20	25	48.07	5	76	-0.040	0.040
	28	98	102	65	16	22	25	50.25	5	82	-0.040	0.040
	32	112	116	75	20	25	25	55.37	5	92	-0.040	0.040
4	16	64	69	48	16	15	25	45.50	6	65	-0.030	0.030
	18	72	77	55	16	18	25.5	49.55	6	71	-0.030	0.030
	20	80	85	60	16	20	27	49.97	6	74	-0.030	0.030
	22	88	93	62	16	22	27	55.38	6	82	-0.040	0.040
	25	100	105	70	20	24	25	54.84	6	86	-0.040	0.040
	28	112	117	80	20	26	25	55.28	6	91	-0.040	0.040
	32	128	133	90	20	28	30	59.75	6	102	-0.040	0.040
5	16	80	86	60	16	18	25	50.14	7	75	-0.030	0.030
	18	90	96	63	16	20	30	54.56	7	83	-0.040	0.040
	20	100	106	70	20	22	30	59.99	7	92	-0.040	0.040
	22	110	116	80	20	24	30	60.41	7	96	-0.040	0.040
	25	125	131	85	20	28	35	69.71	7	110	-0.040	0.040
	28	140	146	90	20	30	38	74.67	7	121	-0.040	0.040
	32	160	166	100	20	32	45	85.16	7	140	-0.040	0.040

BEVEL GEARS FOR TRANSMISSIONS BETWEEN ORTHOGONAL AXES

Straight teeth Bevel Gears sized in compliance with DIN 3971

Corrected toothing by profile displacement and length-wise crowning of the tooth

Pressure angle: 20°

Gear ratio = 1:2

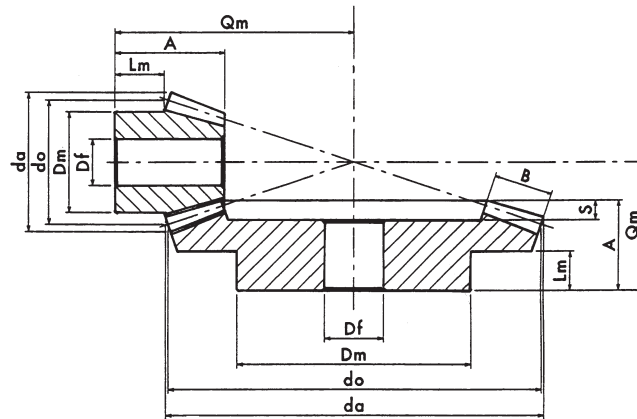

MATERIAL: C 43 STEEL – UNI 7847

M	z	do	da	Dm	Df	B	Lm	A	S	Qm	Tolerance Qm	
											min.	max
1	16	16	18	12	4	6	5	11.78	2	22	-0.020	0.020
	32	32	32	18	5	6	10	18.04		23	-0.020	0.020
1.5	16	24	27	18	8	10	10.5	21.53	3	36	-0.030	0.030
	32	48	48	30	8	10	14	24.97		32	-0.030	0.030
2	16	32	36	24	8	12	11	24.56	4	45	-0.030	0.030
	32	64	64.5	36	12	12	13	28.08		38	-0.030	0.030
2.5	16	40	45.5	32	12	15	15	32.45	5	58	-0.030	0.030
	32	80	80.5	48	16	15	18	37.60		50	-0.030	0.030

Gear ratio = 1:2

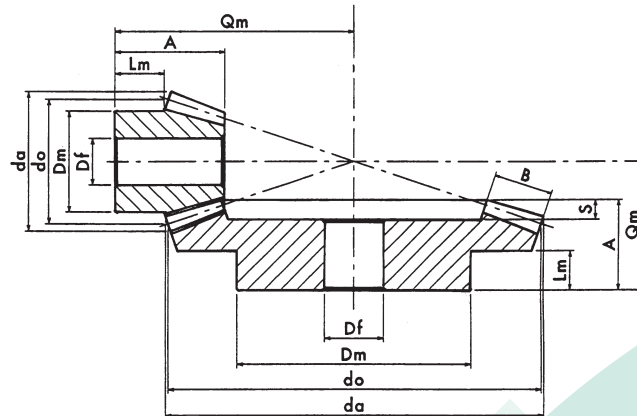

MATERIAL: C 43 STEEL – UNI 7847

M	z	do	da	Dm	Df	B	Lm	A	S	Qm	Tolerance Qm	
											min.	max
3	16	48	55	36	14	18	14	34.34	3	65	-0.040	0.040
	32	96	97	60	14	18	20	40.12		55	-0.040	0.040
3.5	16	56	64	42	14	22	18	42.10	3	77	-0.040	0.040
	32	112	113	70	16	22	22	45.06		62	-0.040	0.040
4	16	64	73	48	14	24	20	45.13	4	86	-0.040	0.040
	32	128	129	80	20	24	25	50.16		70	-0.040	0.040
5	16	80	91	56	16	30	25	59.91	5	111	-0.040	0.040
	32	160	161	100	20	30	30	60.20		85	-0.040	0.040

BEVEL GEARS FOR TRANSMISSIONS BETWEEN ORTHOGONAL AXES

Straight teeth Bevel Gears sized in compliance with DIN 3971

Corrected toothing by profile displacement and length-wise crowning of the tooth

Pressure angle: 20°

Gear ratio = 1:3

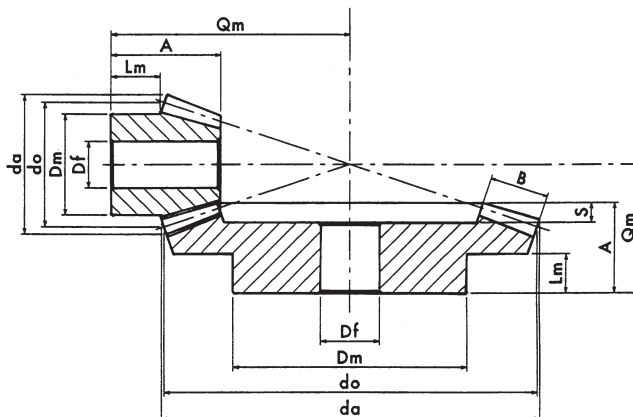

MATERIAL: C 43 STEEL – UNI 7847

M	z	do	da	Dm	Df	B	Lm	A	S	Qm	Tolerance Qm	
											min.	max
1	16	16	18	12	4	8	7.3	15.91	2.5	32	-0.030	0.030
	48	48	47.5	26	8	8	12	21.85		27	-0.030	0.030
1.5	16	24	27.5	18	8	10	9	20.01	3	46	-0.040	0.040
	48	72	71.5	46	12	10	14	25.68		34	-0.040	0.040
2	16	32	37	25	10	14	12.8	27.96	4	62	-0.040	0.040
	48	96	95.5	55	16	14	17	32.11		43	-0.040	0.040
2.5	16	40	46.3	32	12	18	15.6	34.92	5	77	-0.050	0.050
	48	120	119.5	70	20	18	20	40.54		54	-0.050	0.050

Gear ratio = 1:3

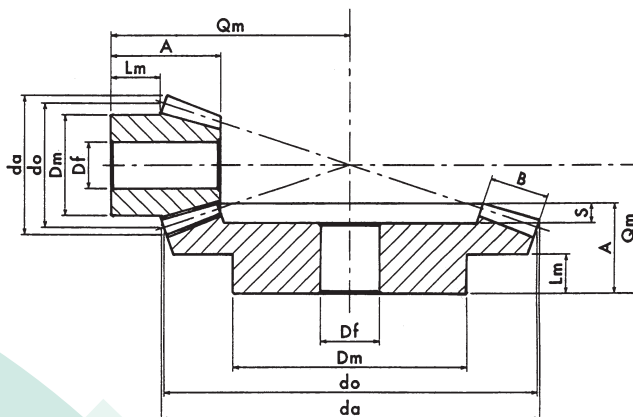

MATERIAL: C 43 STEEL – UNI 7847

M	z	do	da	Dm	Df	B	Lm	A	S	Qm	Tolerance Qm	
											min.	max
3	16	48	55.5	38	14	22	16.3	39.88	3	90	-0.050	0.050
	48	144	144	80	20	22	20	44.96		61	-0.050	0.050
3.5	16	56	65	48	16	25	18.6	44.91	7	104	-0.050	0.050
	48	168	168	90	20	25	25	50.09		69	-0.050	0.050
4	16	64	74.5	52	16	28	18	47.93	7	116	-0.060	0.060
	48	192	192	100	20	28	25	55.22		77	-0.060	0.060
5	16	80	93	63	16	35	27	64.92	9	150	-0.060	0.060
	48	240	240.5	140	20	35	30	64.78		92	-0.060	0.060

BEVEL GEARS FOR TRANSMISSIONS BETWEEN ORTHOGONAL AXES

Straight teeth Bevel Gears sized in compliance with DIN 3971

Corrected toothing by profile displacement and length-wise crowning of the tooth

Pressure angle: 20°

Gear ratio = 1:4

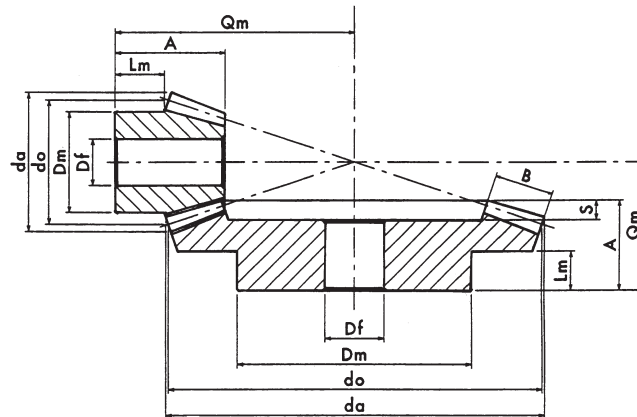

MATERIAL: C 43 STEEL – UNI 7847

M	z	do	da	Dm	Df	B	Lm	A	S	Qm	Tolerance Qm	
											min.	max
1	16	16	18	14	4	10	7.75	17.94	2.5	40	-0.040	0.040
	64	64	63.5	38	8	10	12	21.69		27	-0.040	0.040
1.5	16	24	27.5	20	8	12	12.45	25.08	3	61	-0.050	0.050
	64	96	95.5	56	16	12	15	30.35		39	-0.050	0.050
2	16	32	37	26	10	16	11.2	28.11	4	76	-0.050	0.050
	64	128	127.5	75	16	16	16	32.47		44	-0.050	0.050
2.5	16	40	46.5	32	14	20	14	35.13	5	95	-0.060	0.060
	64	160	159.5	90	20	20	20	40.58		55	-0.060	0.060

Gear ratio = 1:4

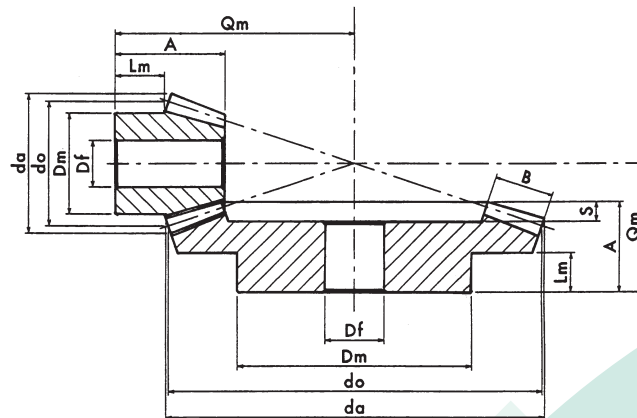

MATERIAL: C 43 STEEL – UNI 7847

M	z	do	da	Dm	Df	B	Lm	A	S	Qm	Tolerance Qm	
											min.	max
3	16	48	56	40	14	25	13	39.12	2	110	-0.060	0.060
	64	192	191.5	100	20	25	20	44.93		62	-0.060	0.060
3.5	16	56	66	48	16	28	15	44.19	3	128	-0.070	0.070
	64	224	223.5	120	20	28	30	59.82		80	-0.070	0.070
4	16	64	75	52	16	32	20.5	54.22	3	150	-0.070	0.070
	64	256	255.5	140	20	32	35	70.93		8	-0.070	0.070
5	16	80	94.5	65	16	36	22.1	60.44	4	184	-0.080	0.080
	64	320	320	170	20	36	35	75.24		10	-0.080	0.080

LOAD-BEARING CAPACITY OF BEVEL GEARS

DESIGNED FOR TRANSMISSION BETWEEN ORTHOGONAL AXES

The mechanical performance or the load-bearing capacity of bevel gears is defined by the twisting moments that the gears are capable of transmitting:

- in the form of dynamic torque, when in motion;
- in the form of static torque, when stationary or moving slowly.

The dynamic torque (M_d) represents the limiting torque yielding due to bending fatigue, whereas the static torque (M_s) indicates the limiting torque at failure by yielding due to tooth bending.

The values declared for both torques are the maximum permitted values and have been tested in compliance with the calculation codes and based on the limiting stress values detailed in the DIN 3991 STANDARDS method C.

The test calculations are valid for a Service Factor (SF) equal to 1 in the absence of data regarding the real operating conditions. **We recommend adopting a safety factor equal to at least 1.5 to adjust the nominal torque to the operating torque.**

LOAD-BEARING CAPACITY OF BEVEL GEARS FOR TRANSMISSIONS BETWEEN ORTHOGONAL AXES

Ratio	M	Z	M_d (Nm)	M_s (Nm)	M	Z	M_d (Nm)	M_s (Nm)	
1:1	1	16	1.35	3.6	3	16	36.8	96	
		18	1.61	4.25		18	48	107	
		20	2	5.35		20	60	158	
		22	2.5	6.55		22	68	182	
		25	3.2	8.35		25	90	235	
		28	4	10.4		28	105	276	
	1.5	32	5.25	13.8	32	135	354		
		16	4.4	11.5	3.5	16	58	152	
		18	5.5	14.35		18	71	171	
		20	6.7	17.6		20	90	246	
		22	8	21.10		22	111	300	
		25	10.5	27.6		25	140	361	
28	13.2	35.	28	175		449			
2	2	32	17.2	40.10	4	32	218	584	
		16	10	26.3		5	16	83.6	219
		18	12.5	30			18	111	290
		20	15	39.5			20	138	360
		22	18.6	48.8			22	167	437
		25	25.4	65.5			25	212	554
	28	31.5	82.5	28	260		681		
	2.5	32	40	95.15	32	327	855		
		16	18.5	48.5	5	16	159	415	
		18	24	62		18	201	525	
		20	29.5	68.8		20	248	645	
		22	36	94		22	300	782	
25		45	118	25		394	1029		
28	58.5	132	28	480		1253			
	32	76.5	200	32	595	1557			

Ratio	M	Dynamic torque M_d		Static torque M_s		
1:2	1	6.5	Nm	17.2	Nm	
	1.5	23.5	Nm	61.5	Nm	
	2	52.3	Nm	137	Nm	
	2.5	102	Nm	267	Nm	
	3	176	Nm	460	Nm	
	3.5	287	Nm	745	Nm	
	4	416	Nm	1086	Nm	
	5	808	Nm	2114	Nm	
	1:3	1	18.5	Nm	48.5	Nm
		1.5	55	Nm	145	Nm
		2	136	Nm	355	Nm
		2.5	270	Nm	704	Nm
3		470	Nm	1228	Nm	
3.5		731	Nm	1910	Nm	
1:4	4	1074	Nm	2807	Nm	
	5	2085	Nm	3508	Nm	
	1	40.5	Nm	106	Nm	
	1.5	117	Nm	306	Nm	
	2	277	Nm	724	Nm	
	2.5	540	Nm	1410	Nm	
1:5	3	956	Nm	2500	Nm	
	3.5	1471	Nm	3845	Nm	
	4	2087	Nm	5454	Nm	
	5	3926	Nm	10270	Nm	

LOAD-BEARING CAPACITY OF BEVEL GEARS FOR TRANSMISSIONS BETWEEN ORTHOGONAL AXES

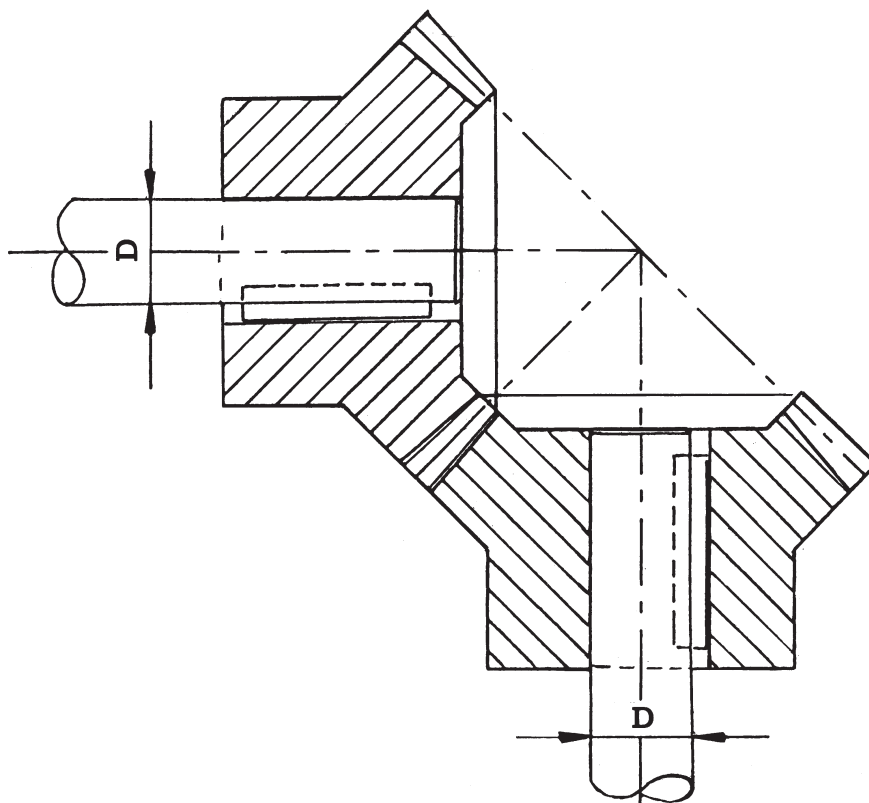

Shaft D = this is the minimum shaft diameter capable of transmitting the dynamic twisting torque with a shear stress equal to 60 N/sq. mm.

Ratio	M	Z	Shaft D	$M_s (N_m)$	M	Z	$M_d (N_m)$	Shaft D
1:1	1	16	4	3.6	3	16	13	96
		18	5	4.25		18	15	107
		20	5	5.35		20	16	158
		22	5	6.55		22	16	182
		25	6	8.35		25	18	235
		28	6	10.4		28	19	276
	32	7	13.8	32	20	354		
	1.5	16	7	11.5	3.5	16	15	152
		18	7	14.35		18	17	171
		20	8	17.6		20	18	246
		22	8	21.1		22	19	300
		25	9	27.6		25	21	361
		28	9	35		28	22	449
	32	10	40.1	32	24	584		
	2	16	9	26.3	4	16	17	219
		18	9	30		18	19	290
		20	10	39.5		20	21	360
		22	11	48.8		22	22	437
		25	12	65.5		25	24	554
		28	13	82.5		28	25	681
	32	14	95.15	32	28	855		
	2.5	16	11	48.5	5	16	22	415
		18	12	62		18	23	525
		20	12	68.8		20	25	645
22		13	94	22		27	782	
25		14	118	25		29	1029	
28		16	132	28		31	1253	
32	17	200	32	34	1557			

LOAD-BEARING CAPACITY OF BEVEL GEARS FOR TRANSMISSIONS BETWEEN ORTHOGONAL AXES

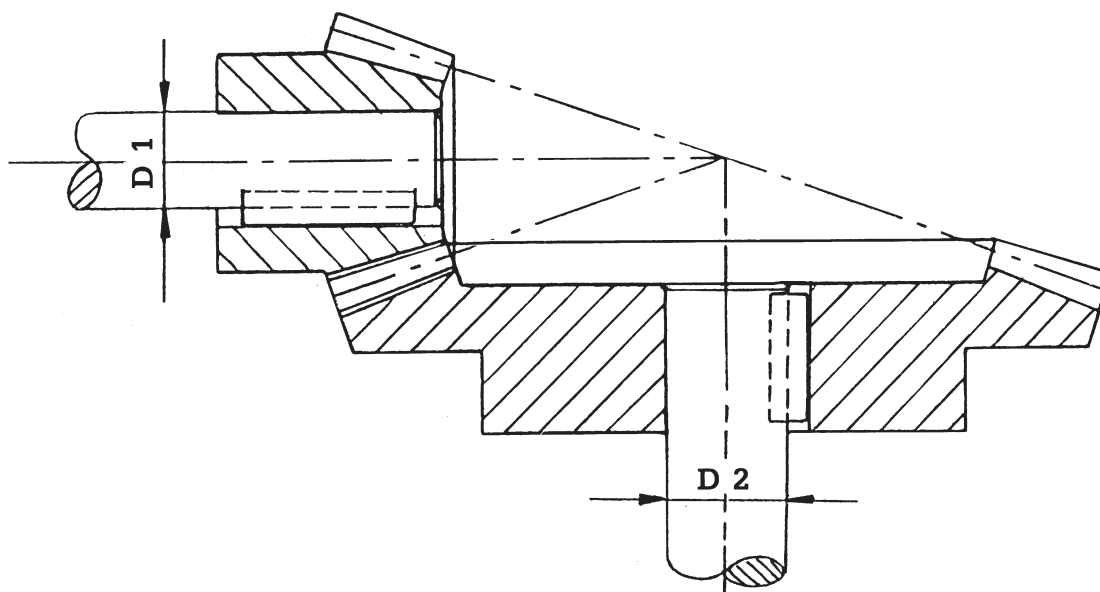

D1 = minimum shaft diameter on sprocket input.

D2 = minimum shaft diameter on wheel

N.B. - The shaft diameters are sized to the output dynamic torque and are tested to withstand a shear stress equal to 60 N/sq. mm.

Ratio	M	Dynamic torque M_d		Static torque M_s		D1	D2
1:2	1	6.5	Nm	17.2	Nm	6	7
	1.5	23.5	Nm	61.5	Nm	9	11
	2	52.3	Nm	137	Nm	12	15
	2.5	102	Nm	267	Nm	15	19
	3	176	Nm	460	Nm	18	22
1:3	3.5	287	Nm	745	Nm	21	26
	4	416	Nm	1086	Nm	24	30
	5	808	Nm	2114	Nm	30	37
	1	18.5	Nm	48.5	Nm	7	11
	1.5	55	Nm	145	Nm	11	15
1:4	2	136	Nm	355	Nm	14	21
	2.5	270	Nm	704	Nm	18	26
	3	470	Nm	1228	Nm	22	31
	3.5	731	Nm	1910	Nm	25	36
	4	1074	Nm	2807	Nm	28	41
1:5	5	2085	Nm	3508	Nm	35	51
	1	40.5	Nm	106	Nm	9	14
	1.5	117	Nm	306	Nm	12	20
	2	277	Nm	724	Nm	16	26
	2.5	540	Nm	1410	Nm	20	33
1:6	3	956	Nm	2500	Nm	25	39
	3.5	1471	Nm	3845	Nm	29	45
	4	2087	Nm	5454	Nm	32	51
	5	3926	Nm	10270	Nm	40	63

LOAD-BEARING CAPACITY OF BEVEL GEARS FOR TRANSMISSIONS BETWEEN ORTHOGONAL AXES WITH SPIRAL TOOTHING

The "GLEASON" system range of bevel gears with spiral tothing is an extension of the range of standard bevel gear pairs with which this range shares the declared intentions and objectives.

The criteria adopted comply as closely as possible with International Standards as regards general sizing and the definition of the geometric features, whereas the choice of the key nominal data has been based on a progression depending on the range of the normal numbers established by the DIN 323 and ISO R3/R17 standards.

The spiral tothing complying with the "GLEASON" system is the result of a specific project designed to achieve optimised functional features compared with the geometric parameters that frequently conflict with each other.

The key sizing for the tothing, in particular refers to the following:

- The choice of a reduced tooth height - Correction by profile displacement - Adoption of a normal pressure angle:

$\alpha_n = 20^\circ$ - The constant tooth bottom gap along the whole tooth surface and other geometric solutions. This series of bevel gear with spiral tothing is designed for general use in plants and in general mechanical applications. The project has been designed therefore, to privilege the mechanical performance normally requested by this sector and special attention has been paid in defining the geometric features that can determine the tooth covering factor and the restraining reactions which determine the load on the bevel gear pair bearings.

By their very nature bevel gears with spiral tothing are designed for a more demanding use compared with that of straight teeth bevel gear pairs therefore, CHIARAVALLI TRASMISSIONI has made available the Company's range of bevel gear pairs with the intention of providing a solution that will be appreciated by the users of this product.

Naturally and in the framework of the Company's traditional technical collaboration with end users, the CHIARAVALLI TRASMISSIONI technical office is available to provide suggestions concerning more specific circumstances and problems.

Directions and angles of forces acting on spiral bevel gears

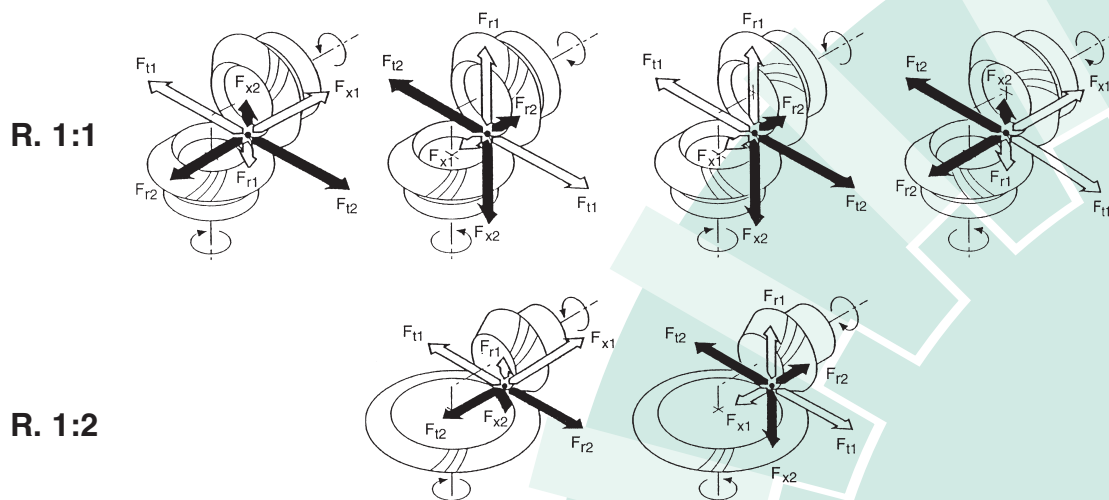

Pinion with left-handed spiral as the drive wheel
Sprocket with right-handed spiral as the driven wheel



"GLEASON" SPIRAL BEVEL GEARS

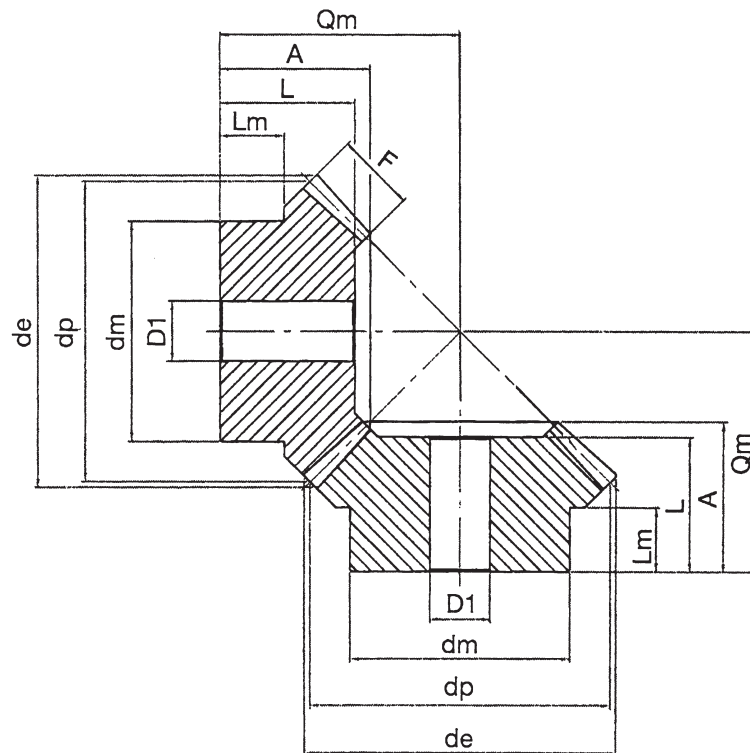

RATIOS 1:1

M	z	dp	dm	D1	F	de	Lm	L	A	Qm
1.5	16	24	18	8	6	25.3	9	16	16.7	24
	20	30	22	8	7	31.3	10	18	19.4	29
	25	37.5	28	8	8	38.8	11.5	21	22.5	35
	30	45	32	10	10	46.3	11	23	25.1	40
2	16	32	25	10	9	34	9.45	16.9	19.9	29
	20	40	32	10	12	42	11.95	21.7	24.9	36
	25	50	40	12	14	52	11.9	24.8	27.4	42
	30	60	50	12	16	62	12.95	26.9	29.9	48
2.5	16	40	32	12	10	42.5	13	21.8	24.8	37
	20	50	40	12	12	52.5	16	26.7	30.2	46
	25	62.5	50	15	15	65	16	29.9	33.2	53
	30	75	55	15	18	77.5	16	31.8	35	59
3	16	48	40	15	12	51	16	25.8	29.4	44
	20	60	45	15	18	63	13.5	30.7	34.5	51
	25	75	55	15	20	78	16	33.7	37.5	60
	30	90	60	20	22	93	19	35.8	39.5	68
4	16	64	50	15	15	68	17.75	30.8	36	56
	20	80	60	18	17	84	18	32.5	37.5	64
	25	100	70	20	21	104	18	35.2	40.4	74
	30	120	80	25	25	124	16	38.1	43.2	84
5	16	80	60	20	17	85	18.9	35.5	41.9	68
	20	100	70	20	21	105	18.5	37.7	44.8	78
	25	125	90	20	26	130	18.5	41.8	47.8	90
	30	150	110	30	32	155	18	45.7	52.5	103

MATERIAL: C 43 UNI 7847

"GLEASON" SPIRAL BEVEL GEARS

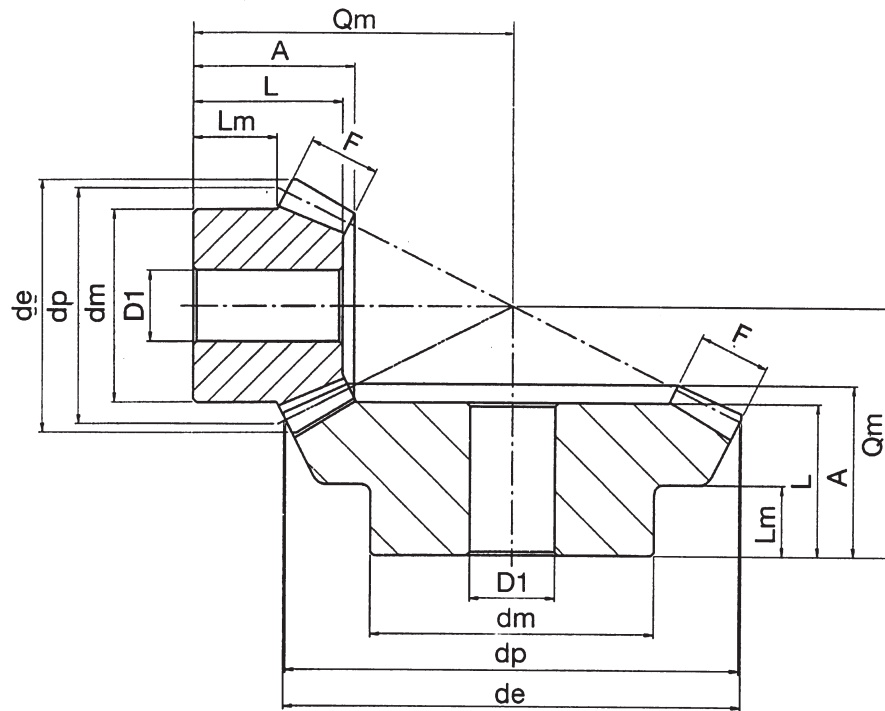

RATIOS 1:2

M	z	dp	dm	D1	F	de	Lm	L	A	Qm	
1.5	16	24	20	10	8	26.50	9.5	17	18.6	35	-0.05 -0.10
	32	48	32	12	8	48.30	10	18	20.0	28	-0.05 -0.10
2	16	32	27	10	10	35.50	11.7	21	22.5	45	-0.05 -0.10
	32	64	40	12	10	64.50	10	21.5	24.1	35	-0.05 -0.10
2.5	16	40	32	12	12	44.50	14	25.1	27.5	56	-0.05 -0.10
	32	80	50	15	12	80.50	15	25.9	29.2	43	-0.05 -0.10
3	16	48	40	15	15	53.50	12	25.2	28.4	62	-0.076 -0.127
	32	96	60	15	15	97.00	15	29.8	34.6	51	-0.076 -0.127
4	16	64	50	20	20	71.50	13.5	32.2	36.2	81	-0.102 -0.152
	32	128	80	20	20	129.00	23	38.7	44.2	66	-0.102 -0.152
5	16	80	60	20	25	89.50	21	45.3	50.0	106	-0.127 -0.178
	32	160	90	25	25	162.00	27	46.8	53.7	81	-0.127 -0.178

MATERIAL: C 43 UNI 7847



ADJUSTABLE PHOSPHATED TAPER-LOCK® PULLEYS FOR V-BELTS

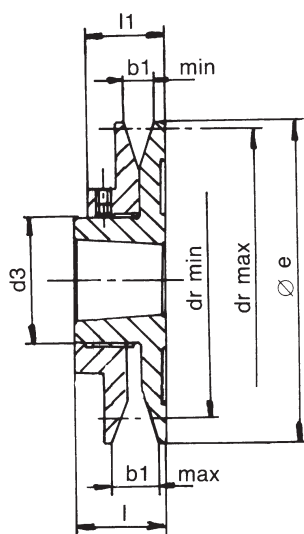

EXECUTION 1

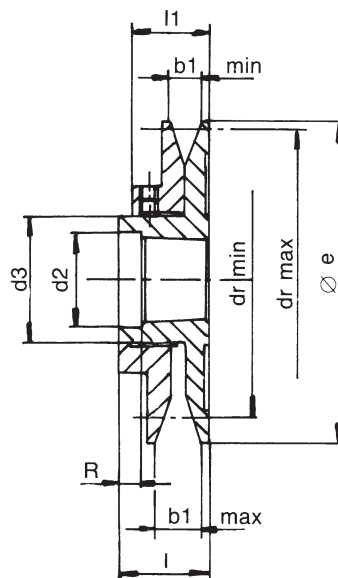

EXECUTION 2

MATERIAL: C 40 STEEL – UNI 7845

PULLEY TYPE	Exec.	No. of Races	Bush	Ø e	l	l ₁	b ₁		d _r		d ₂	d ₃	R	Cup dowels UNI 5929	Belt cross-section	Weight Kg.
							min.	max.	min.	max.						
PRB - 93	2	1	1108	93	36.5	29	13	20.5	57 59	78 85	39	50	13.5	No. 4 M6x6	Z 10x6 A 13x8	0.86
PRB - 108	1	1	1215	108	38	30.5	13	20.5	68	92	-	60	-	No. 4 M6x6	Z 10x6 A 13x8 SPZ SPA	1.18
									75	93						
									76	102						
PRB - 120	1	1	1215	120	38	30.5	13	20.5	80	104	-	60	-	No. 4 M6x6	Z 10x6 A 13x8 SPZ SPA	1.46
									82	112						
									87	105						
									88	114						
PRB - 138	1	1	1615	138	38	30.5	13	20.5	98	122	-	74	-	No. 4 M6x6	Z 10x6 A 13x8 SPZ SPA	2.00
									100	130						
									105	123						
									106	132						
									106	132						
PRB - 160	2	1	1615	160	45	35.5	17	26.5	108	138	58	74	6.5	No. 4 M8x8	A 13x8 B 17x11 SPA SPB	3.04
									112	150						
									114	140						
									117	153						
									117	153						
PRB - 180	2	1	2012	180	45	35.5	17	26.5	128	158	71	90	12.5	No. 4 M8x8	A 13x8 B 17x11 SPA SPB	3.80
									132	170						
									134	160						
									137	173						
									137	173						
PRB - 200	2	1	2012	200	45	35.5	17	26.5	149	177	71	90	12.5	No. 4 M8x8	A 13x8 B 17x11 SPA SPB	4.75
									152	190						
									155	179						
									159	193						
									159	193						

ADJUSTABLE PHOSPHATED TAPER-LOCK® PULLEYS FOR V-BELTS

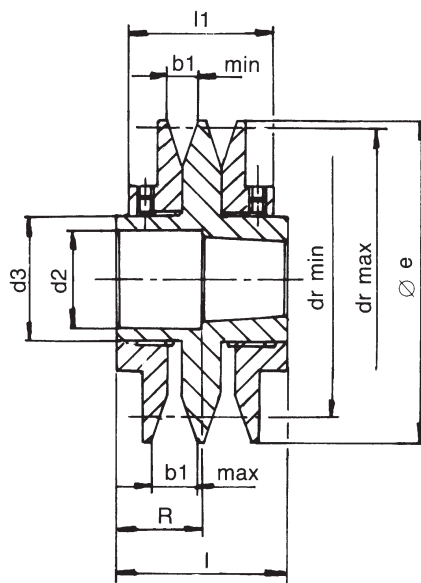

EXECUTION 3

MATERIAL: C 40 STEEL – UNI 7845

PULLEY TYPE	Exec.	No. of Races	Bush	$\varnothing e$	l	l_1	b_1		d_r		d_2	d_3	R	Cup dowels UNI 5929	Belt cross-section	Weight Kg.
							min.	max.	min.	max.						
PRB2 - 108	3	2	1215	108	73	58	13	20.5	68 70 75 76	92 100 93 102	48.5	60	34.5	No. 8 M6x6	Z 10x6 A 13x8 SPZ SPA	2.14
PRB2 - 120	3	2	1215	120	73	58	13	20.5	80 82 87 88	104 112 105 114	48.5	60	34.5	No. 8 M6x6	Z 10x6 A 13x8 SPZ SPA	2.65
PRB2 - 138	3	2	1615	138	73	58	13	20.5	98 100 105 106	122 130 123 132	58.5	74	34.5	No. 8 M6x6	Z 10x6 A 13x8 SPZ SPA	3.60
PRB2 - 160	3	2	1615	160	87	68	17	26.5	108 112 114 117	138 150 140 153	58.5	74	48.5	No. 8 M8x8	A 13x8 B 17x11 SPA SPB	5.60
PRB2- 180	3	2	2012	180	87	68	17	26.5	128 132 134 137	158 170 160 173	71	90	54	No. 8 M8x8	A 13x8 B 17x11 SPA SPB	7.15
PRB2 - 200	3	2	2012	200	87	68	17	26.5	149 152 155 159	177 190 179 193	71	90	54	No. 8 M8x8	A 13x8 B 17x11 SPA SPB	8.92

POLY – V GROOVED BELTS

Definition

A grooved belt refers to a flat belt made up to form a ring with internal length-wise grooves.

The flat section represents the reinforcing component and the length-wise ribs ensure adequate grip by fitting in the grooves of the corresponding pulleys.

CROSS-SECTION J				CROSS-SECTION L			
Belt type	Extension mm.	Belt type	Extension mm.	Belt type	Extension mm.	Belt type	Extension mm.
180 J	457	400 J	1016	500 L	1270	930 L	2362
190 J	483	410 J	1040	525 L	1333	975 L	2476
200 J	508	420 J	1065	540 L	1371	990 L	2515
220 J	559	430 J	1092	550 L	1397	1065 L	2705
240 J	610	460 J	1168	560 L	1422	1080 L	2743
260 J	660	470 J	1200	595 L	1511	1120 L	2845
280 J	711	490 J	1244	615 L	1562	1150 L	2921
285 J	723	500 J	1270	635 L	1613	1215 L	3086
300 J	762	507 J	1287	655 L	1664	1230 L	3124
310 J	790	520 J	1318	675 L	1715	1295 L	3289
320 J	813	522 J	1326	695 L	1764	1310 L	3327
340 J	864	550 J	1397	725 L	1841	1375 L	3492
350 J	895	560 J	1428	765 L	1943	1455 L	3696
360 J	914	580 J	1473	780 L	1981	1595 L	4051
376 J	955	610 J	1549	795 L	2020	1650 L	4191
380 J	965			815 L	2070	1760 L	4470
				825 L	2096	1820 L	4622
				840 L	2134	1980 L	5029
				865 L	2197	2120 L	5385
				880 L	2235	2400 L	6096
				915 L	2324		

Nominal cross-sections and dimensions

Nominal width: $L = P \times N$

$P = P$ (Distance between pulley races)

$N =$ Number of grooves

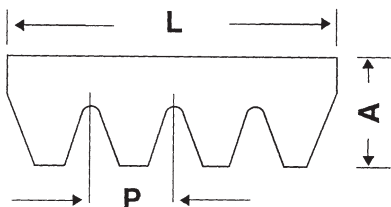

Cross-sections	Pitch P = mm	Height A = mm
P J	2.34	3.60
P L	4.70	6.40

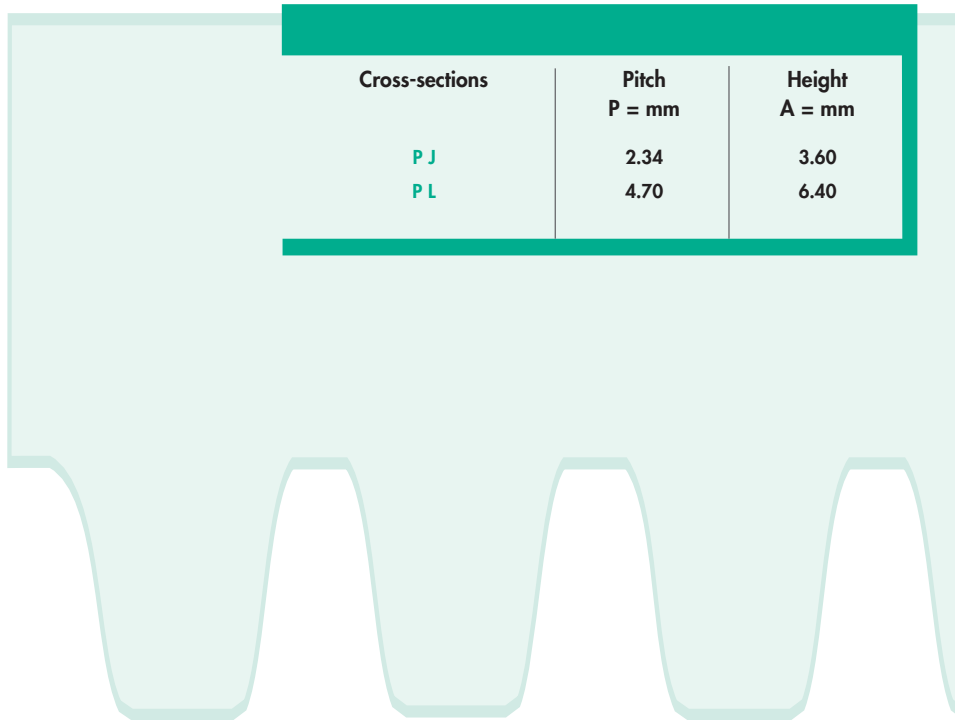

POLY – V TAPER-LOCK®

PULLEYS

Types

Grooved pulleys designed for industrial transmissions are identified by reference to the dimensions and the groove pitch in the following types: **PPV-J – PPV-L**

Profile dimensions

The transverse profile dimensions of a grooved pulley are shown in the figure and in the table.

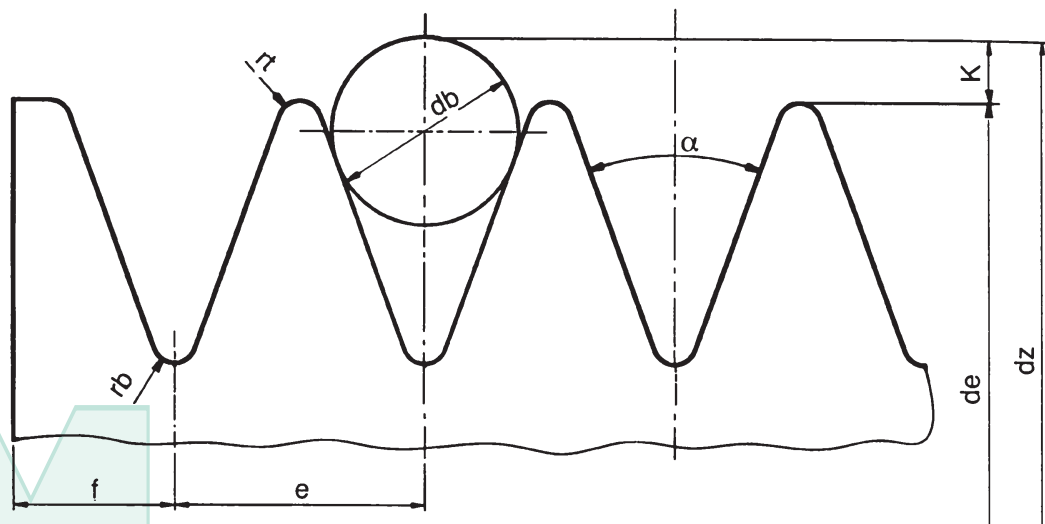

TABLE

Type	PPV-J	PPV-L
Grooves pitch e	2.34	4.70
Tolerance for e^*	± 0.03	± 0.05
Sum of tolerances e^{**}	± 0.30	± 0.30
Race angle $\alpha^{**} \pm 0,5$	40°	40°
rt min.	0.20	0.40
rb max.	0.40	0.40
Diameter of the control sphere or roller $db \pm 0.01$	1.50	3.50
$2K^{**}$ nominal	0.23	2.36
f min.	1.8	3.3

* = this tolerance applies to the distance between the axes of two consecutive grooves

** = the sum of all the tolerances "e" for all the races of each pulley must not exceed the value foreseen in the table

* = the axis of each groove must form a $90^\circ \pm 0.5^\circ$ angle with the pulley axis

** = K is not in relation to the pulley's nominal diameter but is measured from the position of the measurement sphere or roller.

Pitch line diameter

The position of a grooved belt in contact with the corresponding pulley is shown in cross-section in the figure.

The real pitch line diameter d_p of a grooved pulley measured along the belt is slightly greater than the actual diameter d_e and the exact value depends on the type of belt used. For the purposes of illustration, the table shows the value b_e normally adopted to calculate the transmission ratio. In practice it is sufficient to use the actual diameter d_e to calculate the transmission ratio.

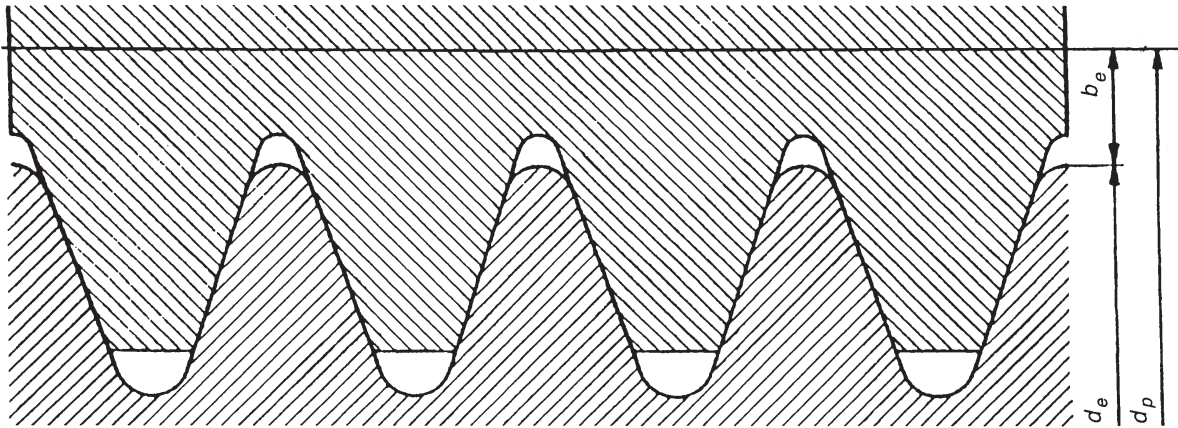

$$d_p \cong d_e + 2b_e$$

Type	PPV-J	PPV-L
$2 b_e$	2	5

Designation

The designation includes the following details, in the order given: the "pulley" domination, the reference of the current standard, the number of grooves, the type and the actual diameter expressed in millimetres.

An example of the designation for a PPV-J type grooved pulley designed for industrial transmissions with 8 grooves and an actual diameter of 200mm.: **8 PPV-J 200**.

Degree of finish of the grooves

The surface roughness of the grooves shall be **Ra 3.2** in compliance with ISO 254.

MATERIALS

C45 UNI 7845

Pulleys are manufactured in steel.

Balancing

UNI 4218 – ISO 1940

Pulleys prepared for a tapered bush are statically balanced within grade G.6.3.

It is possible to perform dynamic balancing, on request.

Dynamic balancing is essential for speeds exceeding 30 m/s.

Design power calculation

Make a note of the nominal power to be transmitted **P** (kw) (normally the nominal power of the electric motor), select the service factor **Co** based on the table and calculate the design power output **Pc** (kw) as follows: **Pc = Co x P**

Service factor (Co)

MOTOR TYPE								
Class A			Class B					
<ul style="list-style-type: none"> Synchronous and asynchronous, squirrel cage, normal torque, alternating current motor. Shunt winding direct current motor Internal combustion engine (steady-state condition ≥ 700 r.p.m.) Turbines 			<ul style="list-style-type: none"> Asynchronous, squirrel cage, high torque alternating current motor Compound winding direct current motor Internal combustion engine (steady-state condition ≥ 700 r.p.m.) Clutches 					
			Class A Motor		Class B Motor			
Type of machine driven			Number of daily operating hours					
			< 10	10 ÷ 16	> 16	< 10	< 10÷ 16	> 16
<ul style="list-style-type: none"> Liquid mixers • Blowers • Extractors Centrifuge fans • Lightweight conveyors 			1	1.1	1.2	1.1	1.2	1.3
<ul style="list-style-type: none"> Mixers designed for pasty products • Blenders • Generators Laundry machines • Machine tools 			1.1	1.2	1.3	1.2	1.3	1.4
<ul style="list-style-type: none"> Rotary compressors • Rotary pumps • Sieves Heavyweight conveyors • Spraying systems • Dynamo Bakery machines • Printing machines Wood working machines • Axial fans Brick making machines 			1.2	1.3	1.4	1.3	1.4	1.5
<ul style="list-style-type: none"> Piston compressors • Piston pumps • Crushers • Bucket elevators Elevators • Paper making machines • Mills • Hoists 			1.4	1.5	1.6	1.5	1.6	1.8
<ul style="list-style-type: none"> Grinding machines • Crushing machines • Drainage systems Calenders and extruders for rubber and plastics 			1.6	1.7	1.8	1.7	1.8	2

CROSS - SECTION SELECTION

The type of cross-section is selected by using the diagram shown below

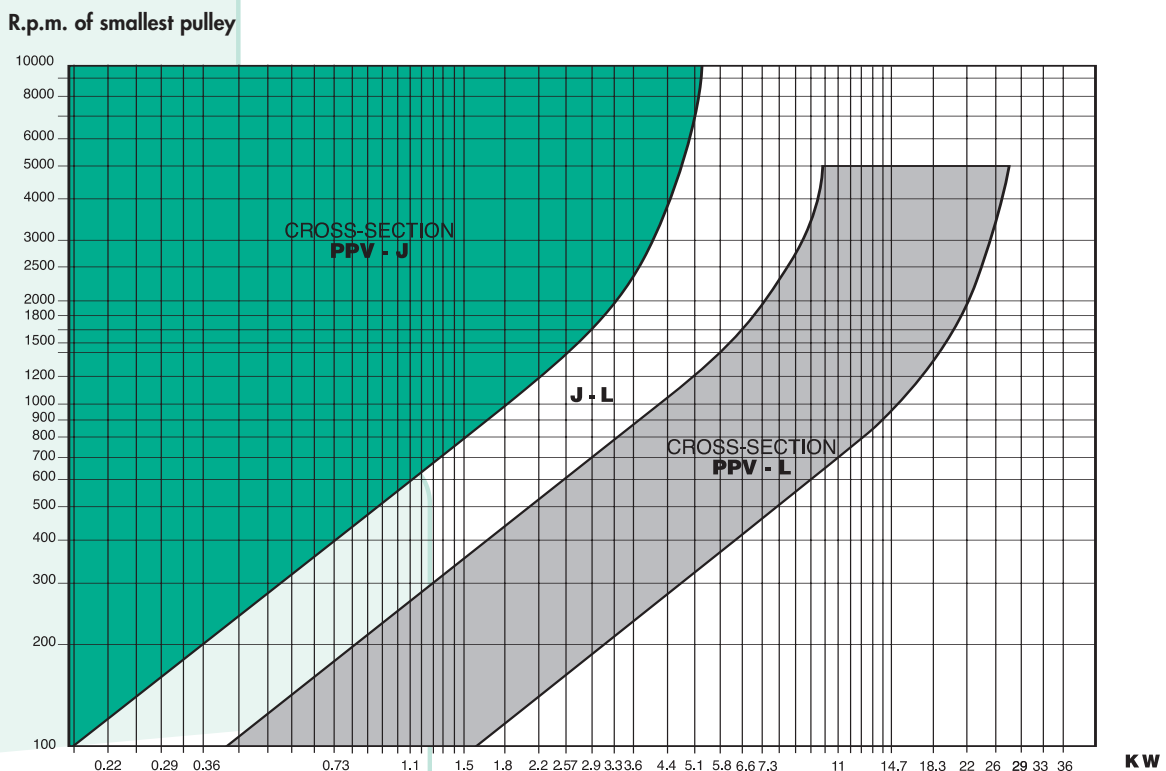

DIMENSIONS OF POLY-V TAPER-LOCK® PULLEYS

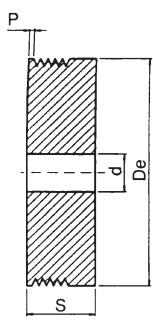

EXECUTION 1

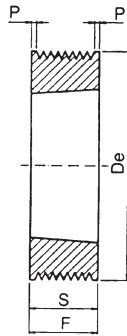

EXECUTION 2

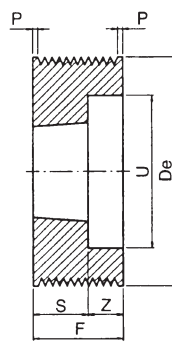

EXECUTION 3

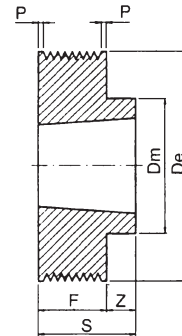

EXECUTION 4

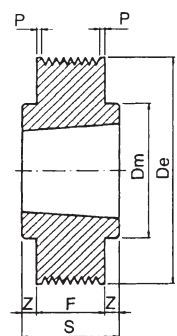

EXECUTION 5

PPV - L CROSS-SECTION

De	Exec.	No. of Grooves	Bush	S	Z	Dm	U		De	Exec.	No. of Grooves	Bush	S	Z	Dm	U	
40	1	8	-	32	-	-	-	12	106	4	8	1610	26	3	82	-	
	1	12	-	41.5	-	-	-	12		3	12	1610	26	6.5	-	88	
	1	16	-	51	-	-	-	12		3	16	1610	26	16	-	88	
45	1	8	-	32	-	-	-	12	112	4	8	1610	26	3	90	-	
	1	12	-	41.5	-	-	-	12		3	12	1610	26	6.5	-	88	
	1	16	-	51	-	-	-	12		3	16	1610	26	16	-	88	
50	1	8	-	32	-	-	-	12	118	4	8	1610	26	3	90	-	
	1	12	-	41.5	-	-	-	12		3	12	2012	32	0.5	-	98	
	1	16	-	51	-	-	-	12		3	16	2012	32	10	-	98	
56	2	8	1108	23	-	-	-	-	125	4	8	1610	26	3	90	-	
	1	12	-	41.5	-	-	-	12		3	12	2012	32	0.5	-	98	
	1	16	-	51	-	-	-	12		3	16	2012	32	10	-	98	
63	2	8	1108	23	-	-	-	-	132	4	8	1610	26	3	90	-	
	3	12	1108	23	9.5	-	46	-		3	12	2012	32	0.5	-	98	
	1	16	-	51	-	-	-	12		3	16	2012	32	10	-	98	
71	2	8	1108	23	-	-	-	-	140	4	8	1610	26	3	90	-	
	3	12	1108	23	9.5	-	46	-		4	12	2517	45	12.5	120	-	
	2	16	1215	42	-	-	55	-		4	16	2517	45	3	120	-	
75	2	8	1108	23	-	-	-	-	160	5	8	2012	32	4.5	110	-	
	3	12	1610	26	6.5	-	60	-		4	12	2517	45	12.5	120	-	
	3	16	1610	26	16	-	60	-		4	16	2517	45	3	120	-	
80	4	8	1610	26	3	70	-	-	180	5	8	2012	32	4.5	110	-	
	3	12	1610	26	6.5	-	60	-		5	12	2517	45	6.25	120	-	
	3	16	1610	26	16	-	60	-		5	16	2517	45	1.5	120	-	
85	4	8	1610	26	3	70	-	-	200	5	8	2012	32	4.5	110	-	
	3	12	1610	26	6.5	-	60	-		5	12	2517	45	6.25	120	-	
	3	16	1610	26	16	-	60	-		5	16	2517	45	1.5	120	-	
90	4	8	1610	26	3	70	-	-	224	5	8	2012	32	4.5	110	-	
	3	12	1610	26	6.5	-	74	-		5	12	2517	45	6.25	120	-	
	3	16	1610	26	16	-	74	-		5	16	2517	45	1.5	120	-	
95	4	8	1610	26	3	82	-	-	250	5	8	2012	32	4.5	110	-	
	3	12	1610	26	6.5	-	74	-		5	12	2517	45	6.25	120	-	
	3	16	1610	26	16	-	74	-		5	16	2517	45	1.5	120	-	
100	4	8	1610	26	3	82	-	-									
	3	12	1610	26	6.5	-	74	-									
	3	16	1610	26	16	-	74	-									

No. of Grooves

F±0.1

P

8

23

3.31

12

32.5

3.38

16

42

3.45

DIMENSIONS OF POLY-V TAPER-LOCK® PULLEYS

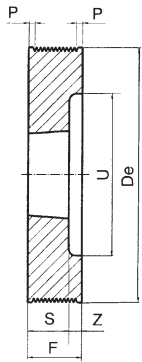

EXECUTION 3

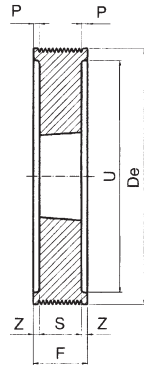

EXECUTION 6

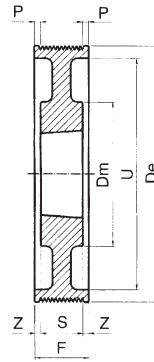

EXECUTION 7

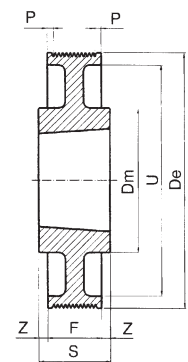

EXECUTION 8

PPV – L CROSS-SECTION

De	Exec.	No. of Grooves	Bush	S	Z	Dm	U	De	Exec.	No. of Grooves	Bush	S	Z	Dm	U
75	3	8	1210	26	22	-	56	140	3	8	2517	45	3	82	116
	3	12	1215	42	25	-	56		6	12	2517	45	11	-	116
									6	16	2517	45	20.5	-	116
80	3	8	1210	26	22	-	56	150	3	8	2517	45	3	-	126
	3	12	1215	42	25	-	56		6	12	2517	45	11	-	126
									6	16	2517	45	20.5	-	126
85	3	8	1210	26	22	-	61	160	3	8	2517	45	3	-	136
	3	12	1215	42	25	-	61		6	12	2517	45	11	-	136
	6	16	1215	42	22	-	61		6	16	3020	52	17	-	136
90	3	8	1610	26	22	-	66	170	3	8	2517	45	3	-	146
	3	12	1615	42	25	-	66		6	12	2517	45	11	-	146
	6	16	1615	42	22	-	66		6	16	3020	52	17	-	146
95	3	8	1610	26	22	-	71	180	3	8	2517	45	3	-	146
	3	12	1615	42	25	-	71		6	12	2517	45	11	-	146
	6	16	1615	42	22	-	71		6	16	3020	52	17	-	146
100	3	8	1610	26	22	-	76	200	7	8	2517	45	1.5	120	156
	3	12	2012	32	35	-	79		7	12	2517	45	11	120	156
	6	16	2012	32	27	-	79		6	16	3020	52	17	-	156
106	3	8	1610	26	22	-	82	224	7	8	2517	45	1.5	120	176
	3	12	2012	32	35	-	82		7	12	3020	52	7.5	146	176
	6	16	2012	32	27	-	82		7	16	3020	52	17	146	176
112	3	8	1610	26	22	-	88	250	7	8	2517	45	1.5	120	202
	3	12	2012	32	35	-	88		7	12	3020	52	7.5	146	202
	6	16	2012	32	27	-	88		7	16	3020	52	17	146	202
118	3	8	2012	32	16	-	94	280	8	8	3020	52	2	146	228
	6	12	2517	45	11	-	97		7	12	3020	52	7.5	146	228
	6	16	2517	45	20.5	-	97		8	16	3535	89	1.5	178	228
125	3	8	2012	32	16	-	101	315	8	8	3020	52	2	146	256
	6	12	2517	45	11	-	101		7	12	3020	52	7.5	146	256
	6	16	2517	45	20.5	-	101		8	16	3535	89	1.5	178	256
132	3	8	2012	32	16	-	108		8	8	3020	52	2	146	285
	6	12	2517	45	11	-	108		8	12	3535	89	11	178	285
	6	16	2517	45	20.5	-	108		8	16	3535	89	1.5	178	285

No. of Grooves	F±0.1	P
8	48	7,55
12	67	7,65
16	86	7,75

POWERGRIP® PULLEYS AND TOOTHED BELTS

FOR SYNCHRONOUS DRIVES

Toothed belts and pulleys are of major importance in synchronous drives based on flexible components. These components enable problems to be overcome efficiently and very economically, problems that would otherwise require the use of kinematic motion gearing or transmissions with articulated link chains.

In fact, the performance provided by synchronous belt drives is analogous to the characteristic performance of both chains and gearing however belts and pulleys by comparison have additional advantages deriving from their structural features.

This evident versatility in application is essentially due to the operating characteristics that are common to all toothed belt synchronous drives, and they can be summarised as follows:

- Transmission of absolute asynchronous motion due to the complete absence of slipping.
- Regular and constant motion, since the toothed belt is free from polygonal winding and the consequent speed variation typical of chain transmissions.
- Non-extendable belt that transmits the motion without significant stretching and therefore without lost motion.
- Moderate assembly pre-tension, since adhesion is not required between the belt and the pulley.
- Minimum radial load on the shafts and on the bearings.
- High capacity to transmit power and high torques at low speed.
- Silent running, good performance, minimum overall dimensions and limited maintenance requirements.

The quality of synchronous transmission depends to an equal extent on the characteristics of both the belt and the pulley, which therefore must comply with demanding design and construction criteria.

CHIARAVALLI Trasmissioni spa avails of the technical collaboration of the most qualified manufacturers of belts worldwide and produces the Company's complete range of toothed pulleys in compliance with current Standards, but implementing a series of adjustments designed to improve the matching characteristics with the belt.

POWERGRIP® GATES® BELTS FOR TIMING BELT PULLEYS

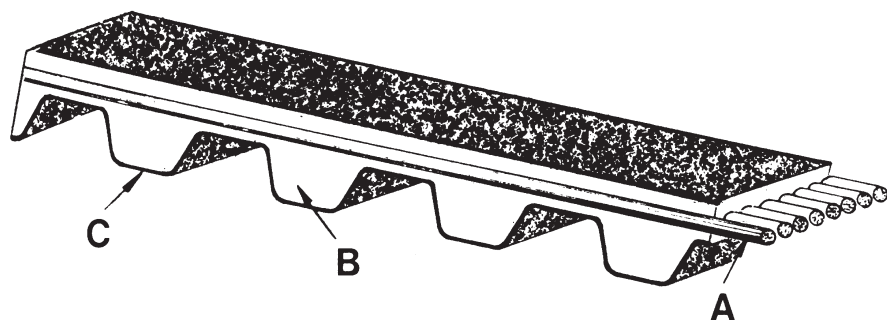

Structural Features

The following components can be identified in the structure of the toothed belts:

- A - Reinforcing insert
- B - Polychloroprene belt body
- C - Teeth lining

DIMENSIONS

XL PITCH CODE 1/5" (5.08 mm.)

Belt type	No. of teeth	Extension	
		inches	mm.
60 XL	30	6.00	152.40
70 XL	35	7.00	177.80
80 XL	40	8.00	203.20
90 XL	45	9.00	228.60
100 XL	50	10.00	254.00
110 XL	55	11.00	279.40
120 XL	60	12.00	304.80
130 XL	65	13.00	330.20
140 XL	70	14.00	355.60
150 XL	75	15.00	381.00
156 XL	78	15.60	396.20
160 XL	80	16.00	406.40
170 XL	85	17.00	431.80
180 XL	90	18.00	457.20
190 XL	95	19.00	482.60
200 XL	100	20.00	508.00
210 XL	105	21.00	533.40
220 XL	110	22.00	558.80
230 XL	115	23.00	584.20
240 XL	120	24.00	609.60
250 XL	125	25.00	635.00
260 XL	130	26.00	660.40
270 XL	135	27.00	685.80
280 XL	140	28.00	711.20
290 XL	145	29.00	736.60
300 XL	150	30.00	762.00
310 XL	155	31.00	787.40
316 XL	158	31.60	802.60
330 XL	165	33.00	838.20
344 XL	172	34.40	873.80
352 XL	176	35.20	894.10
380 XL	190	38.00	965.20
384 XL	192	38.40	975.40
390 XL	195	39.00	990.60

L PITCH CODE 3/8" (9.525 mm.)

Belt type	No. of teeth	Extension	
		inches	mm.
124 L	33	12.37	314.33
150 L	40	15.00	381.00
187 L	50	18.75	476.25
202 L	54	20.25	514.35
210 L	56	21.00	533.40
225 L	60	22.50	571.50
240 L	64	24.00	609.60
255 L	68	25.50	647.70
270 L	72	27.00	685.80
285 L	76	28.50	723.90
300 L	80	30.00	762.00
322 L	86	32.25	819.15
345 L	92	34.50	876.30
367 L	98	36.75	933.45
390 L	104	39.00	990.60
420 L	112	42.00	1066.80
450 L	120	45.00	1143.00
480 L	128	48.00	1219.20
510 L	136	51.00	1295.40
540 L	144	54.00	1371.60
600 L	160	60.00	1524.00

STANDARDISED WIDTHS

Code	inches	mm.
031	5/16	7.94
037	3/8	9.52

STANDARDISED WIDTHS

Code	inches	mm.
050	1/2	12.70
075	3/4	19.05
100	1	25.40

POWERGRIP® GATES® BELTS FOR TIMING BELT PULLEYS

DIMENSIONS

H PITCH CODE 1/2" (12.7 mm.)			
Belt type	No. of teeth	Extension	
		inches	mm.
240 H	48	24.00	609.60
270 H	54	27.00	685.80
300 H	60	30.00	762.00
330 H	66	33.00	838.20
360 H	72	36.00	914.40
390 H	78	39.00	990.60
420 H	84	42.00	1066.80
450 H	90	45.00	1143.00
480 H	96	48.00	1219.20
510 H	102	51.00	1295.40
540 H	108	54.00	1371.60
570 H	114	57.00	1447.80
600 H	120	60.00	1524.00
630 H	126	63.00	1600.20
660 H	132	66.00	1676.40
700 H	140	70.00	1778.00
750 H	150	75.00	1905.00
800 H	160	80.00	2032.00
850 H	170	85.00	2159.00
900 H	180	90.00	2286.00
1000 H	200	100.00	2540.00
1100 H	220	110.00	2794.00
1250 H	250	125.00	3175.00
1400 H	280	140.00	3556.00
1700 H	340	170.00	4318.00

STANDARDISED WIDTHS		
Code	inches	mm.
075	3/4	19.05
100	1	25.40
150	1 1/2	38.10
200	2	50.80
300	3	76.20

XH PITCH CODE 7/8" (22.225 mm.)			
Belt type	No. of teeth	Extension	
		inches	mm.
507 XH	58	50.75	1289.05
560 XH	64	56.00	1422.40
630 XH	72	63.00	1600.20
700 XH	80	70.00	1778.00
770 XH	88	77.00	1955.80
840 XH	96	84.00	2133.60
980 XH	112	98.00	2489.20
1120 XH	128	112.00	2844.80
1260 XH	144	126.00	3200.40
1400 XH	160	140.00	3556.00
1540 XH	176	154.00	3911.60
1750 XH	200	175.00	4445.00

STANDARDISED WIDTHS			
	Code	inches	mm.
200	2	50.80	
300	3	76.20	
400	4	101.60	

XXH PITCH CODE 1" 1/4 (31.75 mm.)			
Belt type	No. of teeth	Extension	
		inches	mm.
700 XXH	56	70.00	1778.00
800 XXH	64	80.00	2032.00
900 XXH	72	90.00	2286.00
1000 XXH	80	100.00	2540.00
1200 XXH	96	120.00	3048.00
1400 XXH	112	140.00	3556.00
1600 XXH	128	160.00	4064.00
1800 XXH	144	180.00	4572.00

STANDARDISED WIDTHS			
	Code	inches	mm.
200	2	50.80	
300	3	76.20	
400	4	101.60	
500	5	127.00	

DUAL POWERGRIP® GATES® BELTS

L PITCH CODE 3/8" (9.525 mm.) DUAL

Belt type	No. of teeth	Extension	
		inches	mm.
210 L DUAL	56	21.00	533.40
240 L DUAL	64	24.00	609.60
255 L DUAL	68	25.50	647.70
270 L DUAL	72	27.00	685.80
285 L DUAL	76	28.50	723.90
300 L DUAL	80	30.00	762.00
322 L DUAL	86	32.25	819.15
345 L DUAL	92	34.50	876.30
367 L DUAL	98	36.75	933.45
390 L DUAL	104	39.00	990.60
420 L DUAL	112	42.00	1066.80
450 L DUAL	120	45.00	1143.00
480 L DUAL	128	48.00	1219.20
510 L DUAL	136	51.00	1295.40
540 L DUAL	144	54.00	1371.60
600 L DUAL	160	60.00	1524.00
660 L DUAL	176	66.00	1676.40

H PITCH CODE 1/2" (12.7 mm.) DUAL

Belt type	No. of teeth	Extension	
		inches	mm.
240 H DUAL	48	24.00	609.60
270 H DUAL	54	27.00	685.80
300 H DUAL	60	30.00	762.00
360 H DUAL	72	36.00	914.40
390 H DUAL	78	39.00	990.60
420 H DUAL	84	42.00	1066.80
450 H DUAL	90	45.00	1143.00
480 H DUAL	96	48.00	1219.20
510 H DUAL	102	51.00	1295.40
540 H DUAL	108	54.00	1371.60
570 H DUAL	114	57.00	1447.80
600 H DUAL	120	60.00	1524.00
630 H DUAL	126	63.00	1600.20
660 H DUAL	132	66.00	1676.40
700 H DUAL	140	70.00	1778.00
750 H DUAL	150	75.00	1905.00
800 H DUAL	160	80.00	2032.00
850 H DUAL	170	85.00	2159.00
900 H DUAL	180	90.00	2286.00
1000 H DUAL	200	100.00	2540.00
1100 H DUAL	220	110.00	2794.00
1250 H DUAL	250	125.00	3175.00
1400 H DUAL	280	140.00	3556.00

POSITIVE BELT PITCH SELECTION

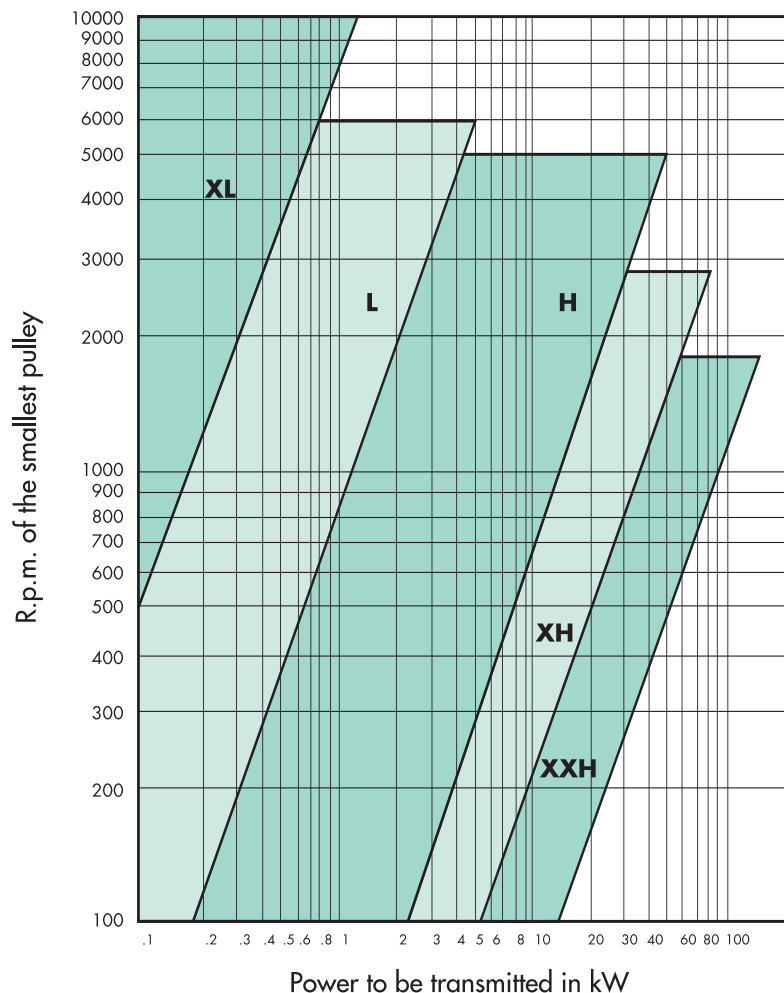

POWERGRIP® TOOTHED PULLEYS FOR SYNCHRONOUS BELTS

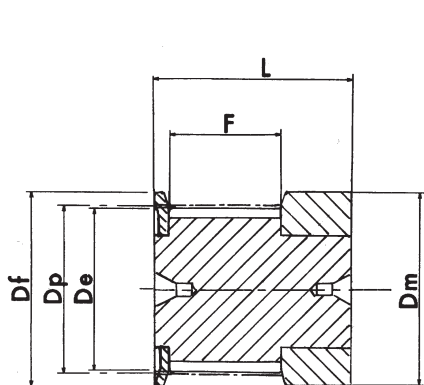

execution 0F

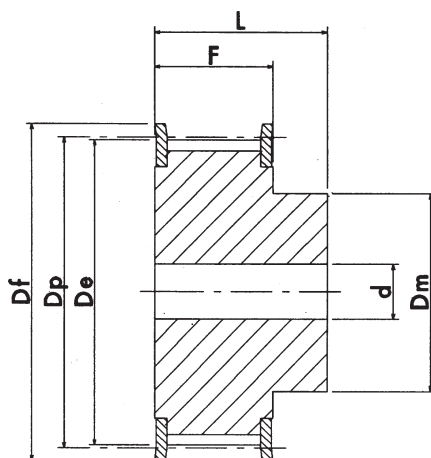

execution 1F

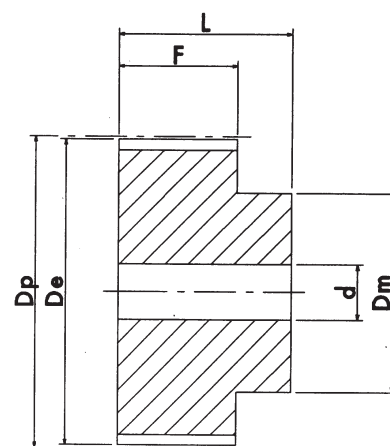

execution 2

MXL 025 PITCH 0.080" (2.032 mm.)

CHARACTERISTICS	TYPE	EXEC.	No. of TEETH	Dp PITCH LINE	De EXTERNAL	Df FLANGE	Dm HUB	F	L	d	FLANGE No.		
ALUMINIUM	WITH FLANGE	16 MXL 025	16	10.35	9.84	15	15	8.5	16	-	502		
		18 MXL 025	18	11.64	11.12	16	16	8.5	16	-	503		
		20 MXL 025	20	12.94	12.43	16	16	8.5	16	-	503		
		22 MXL 025	1F	22	14.23	13.72	17	10	11	16	3	504	
		24 MXL 025	1F	24	15.52	15.01	20	10	11	16	3	505	
		28 MXL 025	1F	28	18.11	17.60	25	11	11	16	3	506	
		30 MXL 025	1F	30	19.40	18.90	25	12	11	16	4	506	
		32 MXL 025	1F	32	20.70	20.19	26	14	11	16	4	507	
		36 MXL 025	1F	36	23.29	22.78	28	16	11	16	4	508	
		40 MXL 025	1F	40	25.87	25.37	32	18	11	16	4	509	
		42 MXL 025	1F	42	27.17	26.67	32	18	11	16	5	509	
		44 MXL 025	1F	44	28.46	27.95	36	18	11	16	5	510	
		ALUMINIUM	WITHOUT FLANGE	48 MXL 025	2	31.05	30.54	-	20	11	16	5	-
				60 MXL 025	2	38.81	38.30	-	24	11	16	5	-
72 MXL 025	2			46.57	46.06	-	25	11	16	6	-		

POWERGRIP® TOOTHED PULLEYS FOR SYNCHRONOUS BELTS

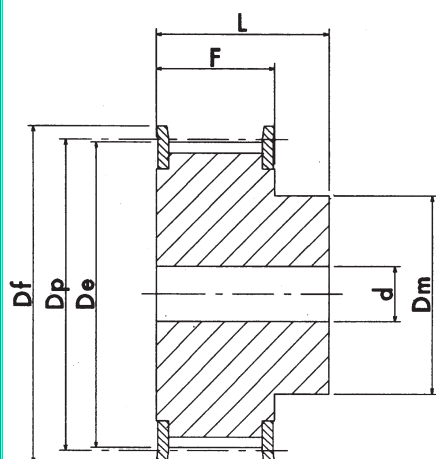

execution 1F

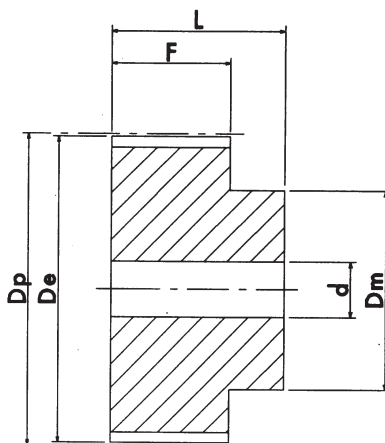

execution 2

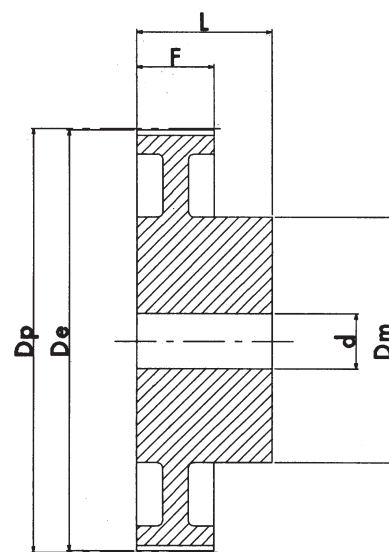

execution 3

XL 037 PITCH 1/5" (5.08 mm.)

CHARACTERISTICS	TYPE	EXEC.	No. of TEETH	Dp PITCH LINE	De EXTERNAL	Df FLANGE	Dm HUB	F	L	d	FLANGE No.	
STEEL/ALUMINIUM	WITH FLANGE	10 XL 037	1F	10	16.17	15.66	23.0	9.5	14.3	20	-	1
		11 XL 037	1F	11	17.79	17.28	23.0	9.5	14.3	20	-	1
		12 XL 037	1F	12	19.40	18.90	25.0	10	14.3	20	-	2
		13 XL 037	1F	13	21.02	20.51	25.0	10	14.3	20	-	2
		14 XL 037	1F	14	22.64	22.13	28.0	15	14.3	20	-	4
		15 XL 037	1F	15	24.26	23.75	28.0	15	14.3	20	-	4
		16 XL 037	1F	16	25.87	25.36	32.0	16	14.3	20	-	5
		17 XL 037	1F	17	27.49	26.98	32.0	20	14.3	20	-	6
		18 XL 037	1F	18	29.11	28.60	35.0	20	14.3	20	-	7
		19 XL 037	1F	19	30.72	30.22	35.0	20	14.3	22	-	7
		20 XL 037	1F	20	32.34	31.83	38.0	23.5	14.3	22	-	9
		21 XL 037	1F	21	33.96	33.45	38.0	23.5	14.3	22	-	9
		22 XL 037	1F	22	35.57	35.07	41.0	25	14.3	22	6	10
		24 XL 037	1F	24	38.81	38.30	44.0	30	14.3	22	6	12
		26 XL 037	1F	26	42.04	41.53	48.0	30	14.3	22	8	11
		27 XL 037	1F	27	43.66	43.15	48.0	30	14.3	22	8	11
		28 XL 037	1F	28	45.28	44.77	51.0	34	14.3	22	8	16
		30 XL 037	1F	30	48.51	48.00	54.0	38	14.3	22	8	18
		32 XL 037	1F	32	51.74	51.24	57.0	38	14.3	25	8	20
34 XL 037	1F	34	54.98	54.47	61.0	38	14.3	25	8	22		
35 XL 037	1F	35	56.60	56.09	61.0	38	14.3	25	8	22		
ALUMINIUM	WITHOUT FLANGE	36 XL 037	2	36	58.21	57.70	-	45	14.3	25	8	-
		38 XL 037	2	38	61.45	60.94	-	45	14.3	25	8	-
		40 XL 037	2	40	64.68	64.17	-	45	14.3	25	8	-
		42 XL 037	2	42	67.91	67.41	-	45	14.3	25	8	-
		44 XL 037	2	44	71.15	70.64	-	45	14.3	25	8	-
		48 XL 037	3	48	77.62	77.11	-	45	14.3	25	10	-
		60 XL 037	3	60	97.02	96.51	-	45	14.3	25	10	-
		72 XL 037	3	72	116.42	115.92	-	45	14.3	25	10	-

POWERGRIP® TOOTHED PULLEYS FOR SYNCHRONOUS BELTS

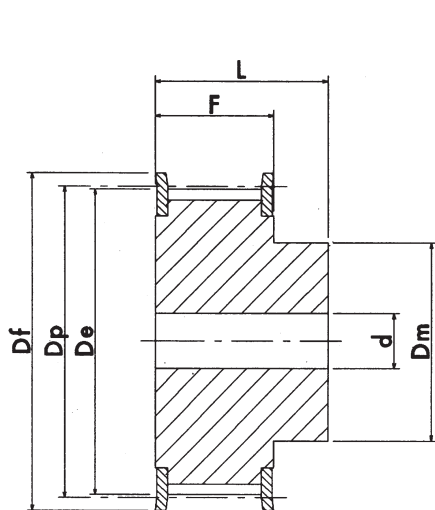

execution 1F

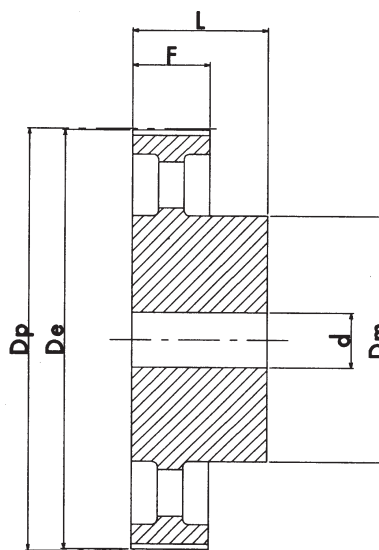

execution 4

L 050 PITCH 3/8" (9.52 mm.)

CHARACTERISTICS	TYPE	EXEC.	No. of TEETH	Dp PITCH LINE	De EXTERNAL	Df FLANGE	Dm HUB	F	L	d	FLANGE No.	
STEEL	WITH FLANGE	10 L 050	1F	10	30.33	29.56	37.00	20	19.0	28	8	50
		11 L 050	1F	11	33.35	32.59	37.00	22	19.0	30	8	50
		12 L 050	1F	12	36.37	35.62	43.00	24	19.0	30	8	52
		13 L 050	1F	13	39.41	38.65	44.00	28	19.0	30	8	83
		14 L 050	1F	14	42.44	41.68	48.00	28	19.0	30	8	54
		15 L 050	1F	15	45.48	44.72	51.00	34	19.0	30	8	55
		16 L 050	1F	16	48.51	47.75	54.00	36	19.0	32	8	56
		17 L 050	1F	17	51.54	50.78	57.00	36	19.0	32	10	57
		18 L 050	1F	18	54.59	53.81	60.00	40	19.0	32	10	58
		19 L 050	1F	19	57.61	56.84	64.00	40	19.0	32	10	59
		20 L 050	1F	20	60.63	59.88	66.50	40	19.0	32	10	60
		21 L 050	1F	21	63.68	62.91	70.00	45	19.0	32	10	61
		22 L 050	1F	22	66.70	65.94	75.00	45	19.0	32	10	62
		23 L 050	1F	23	69.73	68.97	79.00	55	19.0	32	10	63
		24 L 050	1F	24	72.77	72.00	79.00	55	19.0	32	10	63
		25 L 050	1F	25	75.80	75.04	82.50	58	19.0	32	10	64
		26 L 050	1F	26	78.84	78.07	86.00	58	19.0	32	11	65
		27 L 050	1F	27	81.86	81.10	86.00	58	19.0	32	11	65
		28 L 050	1F	28	84.89	84.13	91.00	58	19.0	32	11	66
		30 L 050	1F	30	90.96	90.20	97.00	70	19.0	32	11	68
		32 L 050	1F	32	97.03	96.26	102.00	70	19.0	32	11	70
		33 L 050	1F	33	100.05	99.29	106.00	70	19.0	32	11	71
		34 L 050	1F	34	103.08	102.32	112.00	70	19.0	32	11	72
		35 L 050	1F	35	106.12	105.35	112.00	70	19.0	32	11	72
36 L 050	1F	36	109.14	108.39	115.00	70	19.0	32	11	74		
40 L 050	1F	40	121.29	120.51	128.00	70	19.0	32	11	78		
42 L 050	1F	42	127.34	126.57	135.00	70	19.0	32	11	80		
44 L 050	1F	44	133.40	132.64	142.00	70	19.0	32	11	81		
45 L 050	1F	45	136.44	135.67	142.00	70	19.0	32	11	81		
48 L 050	1F	48	145.54	144.77	150.00	70	19.0	32	11	85		
CAST-IRON	WITHOUT FLANGE	50 L 050	4	50	151.60	150.83	-	70	19.0	32	14	-
		52 L 050	4	52	157.66	156.90	-	70	19.0	32	14	-
		56 L 050	4	56	169.79	169.02	-	70	19.0	32	14	-
		57 L 050	4	57	172.82	172.06	-	70	19.0	32	14	-
		60 L 050	4	60	181.92	181.15	-	75	19.0	42	14	-
		72 L 050	4	72	218.29	217.53	-	75	19.0	42	14	-
		84 L 050	4	84	254.69	253.92	-	75	19.0	42	14	-
		96 L 050	4	96	291.06	290.30	-	75	19.0	42	14	-

POWERGRIP® TOOTHED PULLEYS FOR SYNCHRONOUS BELTS

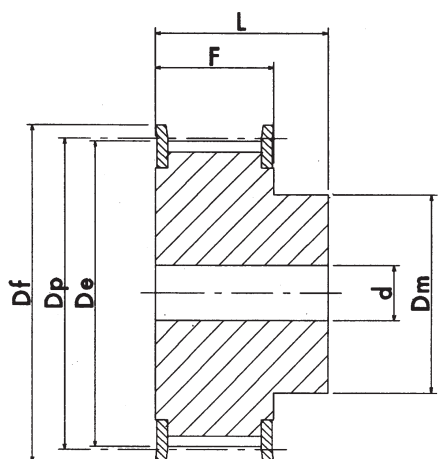

execution 1F

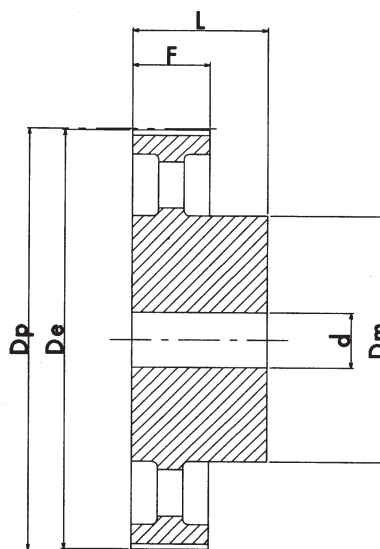

execution 4

L 075 PITCH 3/8" (9.52 mm.)

CHARACTERISTICS	TYPE	EXEC.	No. of TEETH	Dp PITCH LINE	De EXTERNAL	Df FLANGE	Dm HUB	F	L	d	FLANGE No.	
STEEL	WITH FLANGE	10 L 075	1F	10	30.33	29.56	37.0	20	25.4	38	8	50
		11 L 075	1F	11	33.35	32.59	37.0	22	25.4	38	8	50
		12 L 075	1F	12	36.37	35.62	43.0	24	25.4	38	8	52
		13 L 075	1F	13	39.41	38.65	44.0	28	25.4	38	8	83
		14 L 075	1F	14	42.44	41.68	48.0	28	25.4	38	11	54
		15 L 075	1F	15	45.48	44.72	51.0	34	25.4	38	11	55
		16 L 075	1F	16	48.51	47.75	54.0	36	25.4	38	11	56
		17 L 075	1F	17	51.54	50.78	57.0	36	25.4	38	11	57
		18 L 075	1F	18	54.59	53.81	60.0	40	25.4	38	11	58
		19 L 075	1F	19	57.61	56.84	64.0	40	25.4	38	11	59
		20 L 075	1F	20	60.63	59.88	66.5	40	25.4	38	11	60
		21 L 075	1F	21	63.68	62.91	70.0	45	25.4	38	11	61
		22 L 075	1F	22	66.70	65.94	75.0	45	25.4	38	11	62
		23 L 075	1F	23	69.73	68.97	79.0	55	25.4	38	11	63
		24 L 075	1F	24	72.77	72.00	79.0	55	25.4	38	11	63
		25 L 075	1F	25	75.80	75.04	82.5	58	25.4	38	11	64
		26 L 075	1F	26	78.84	78.07	86.0	58	25.4	38	11	65
		27 L 075	1F	27	81.86	81.10	86.0	58	25.4	38	11	65
		28 L 075	1F	28	84.89	84.13	91.0	58	25.4	38	11	66
		30 L 075	1F	30	90.96	90.20	97.0	70	25.4	38	11	68
		32 L 075	1F	32	97.03	96.26	102.0	70	25.4	38	11	70
		33 L 075	1F	33	100.05	99.29	106.0	70	25.4	38	11	71
		34 L 075	1F	34	103.08	102.32	112.0	70	25.4	38	11	72
		35 L 075	1F	35	106.12	105.35	112.0	70	25.4	38	11	72
36 L 075	1F	36	109.14	108.39	115.0	70	25.4	38	11	74		
40 L 075	1F	40	121.29	120.51	128.0	70	25.4	38	11	78		
42 L 075	1F	42	127.34	126.57	135.0	70	25.4	38	11	80		
44 L 075	1F	44	133.40	132.64	142.0	70	25.4	38	11	81		
45 L 075	1F	45	136.44	135.67	142.0	70	25.4	38	11	81		
48 L 075	1F	48	145.54	144.77	150.0	70	25.4	38	11	85		
CAST-IRON	WITHOUT FLANGE	50 L 075	4	50	151.60	150.83	-	70	25.4	38	14	-
		52 L 075	4	52	157.66	156.90	-	70	25.4	38	14	-
		56 L 075	4	56	169.79	169.02	-	70	25.4	38	14	-
		57 L 075	4	57	172.82	172.06	-	70	25.4	38	14	-
		60 L 075	4	60	181.92	181.15	-	75	25.4	45	14	-
		72 L 075	4	72	218.29	217.53	-	75	25.4	45	14	-
		84 L 075	4	84	254.69	253.92	-	75	25.4	45	14	-
		96 L 075	4	96	291.06	290.30	-	75	25.4	45	14	-

POWERGRIP® TOOTHED PULLEYS FOR SYNCHRONOUS BELTS

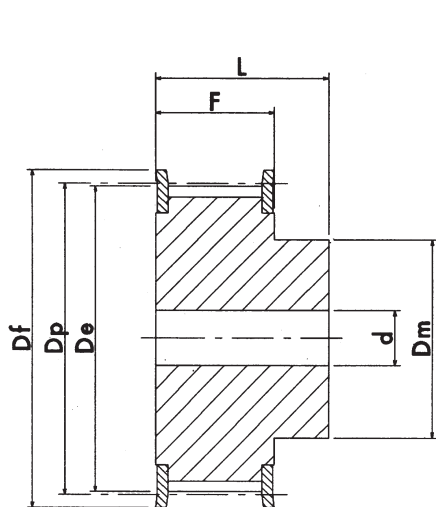

execution 1F

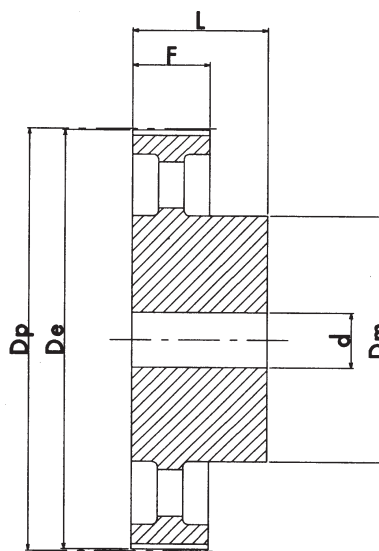

execution 4

L 100 PITCH 3/8" (9.52 mm.)

CHARACTERISTICS	TYPE	EXEC.	No. of TEETH	Dp PITCH LINE	De EXTERNAL	Df FLANGE	Dm HUB	F	L	d	FLANGE No.	
STEEL	WITH FLANGE	10 L 100	1F	10	30.33	29.56	37.0	20	31.8	45	8	50
		11 L 100	1F	11	33.35	32.59	37.0	22	31.8	45	8	50
		12 L 100	1F	12	36.37	35.62	43.0	24	31.8	45	8	52
		13 L 100	1F	13	39.41	38.65	44.0	28	31.8	45	8	83
		14 L 100	1F	14	42.44	41.68	48.0	28	31.8	45	11	54
		15 L 100	1F	15	45.48	44.72	51.0	34	31.8	45	11	55
		16 L 100	1F	16	48.51	47.75	54.0	36	31.8	45	11	56
		17 L 100	1F	17	51.54	50.78	57.0	36	31.8	45	11	57
		18 L 100	1F	18	54.59	53.81	60.0	40	31.8	45	11	58
		19 L 100	1F	19	57.61	56.84	64.0	40	31.8	45	11	59
		20 L 100	1F	20	60.63	59.88	66.5	40	31.8	45	11	60
		21 L 100	1F	21	63.68	62.91	70.0	45	31.8	45	11	61
		22 L 100	1F	22	66.70	65.94	75.0	45	31.8	45	11	62
		23 L 100	1F	23	69.73	68.97	79.0	55	31.8	45	11	63
		24 L 100	1F	24	72.77	72.00	79.0	55	31.8	45	11	63
		25 L 100	1F	25	75.80	75.04	82.5	58	31.8	45	11	64
		26 L 100	1F	26	78.84	78.07	86.0	58	31.8	45	11	65
		27 L 100	1F	27	81.86	81.10	86.0	58	31.8	45	11	65
		28 L 100	1F	28	84.89	84.13	91.0	58	31.8	45	11	66
		30 L 100	1F	30	90.96	90.20	97.0	70	31.8	45	11	68
		32 L 100	1F	32	97.03	96.26	102.0	70	31.8	45	11	70
		33 L 100	1F	33	100.05	99.29	106.0	70	31.8	45	11	71
		34 L 100	1F	34	103.08	102.32	112.0	70	31.8	45	11	72
		35 L 100	1F	35	106.12	105.35	112.0	70	31.8	45	11	72
36 L 100	1F	36	109.14	108.39	115.0	70	31.8	45	11	74		
40 L 100	1F	40	121.29	120.51	128.0	70	31.8	45	11	78		
42 L 100	1F	42	127.34	126.57	135.0	70	31.8	45	11	80		
44 L 100	1F	44	133.40	132.64	142.0	70	31.8	45	11	81		
45 L 100	1F	45	136.44	135.67	142.0	70	31.8	45	11	81		
48 L 100	1F	48	145.54	144.77	150.0	70	31.8	45	11	85		
CAST-IRON	WITHOUT FLANGE	50 L 100	4	50	151.60	150.83	-	70	31.8	45	14	-
		52 L 100	4	52	157.66	156.90	-	70	31.8	45	14	-
		56 L 100	4	56	169.79	169.02	-	70	31.8	45	14	-
		57 L 100	4	57	172.82	172.06	-	70	31.8	45	14	-
		60 L 100	4	60	181.92	181.15	-	75	31.8	45	14	-
		72 L 100	4	72	218.29	217.53	-	75	31.8	45	14	-
		84 L 100	4	84	254.69	253.92	-	75	31.8	45	14	-
		96 L 100	4	96	291.06	290.30	-	75	31.8	45	14	-

POWERGRIP® TOOTHED PULLEYS FOR SYNCHRONOUS BELTS

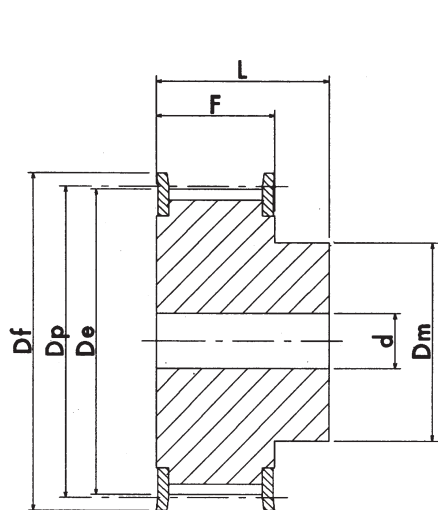

execution 1F

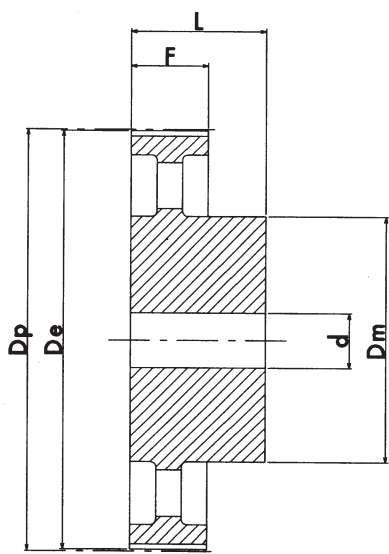

execution 4

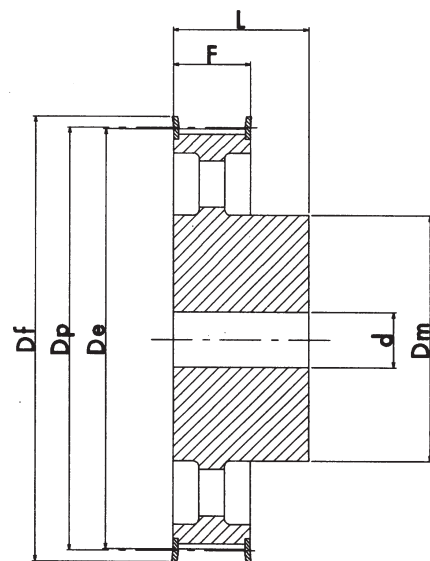

execution 5F

TIPO: H 075 PASSO 1/2" (12.7 mm.)

CHARACTERISTICS	TYPE	EXEC.	No. of TEETH	Dp PITCH LINE	De EXTERNAL	Df FLANGE	Dm HUB	F	L	d	FLANGE No.
STEEL	WITH FLANGE	14 H 075	14	56.59	55.22	64.0	40	26.4	40	-	59
		15 H 075	15	60.64	59.27	66.5	45	26.4	40	-	60
		16 H 075	16	64.67	63.31	70.0	45	26.4	40	-	61
		17 H 075	17	68.72	67.35	75.0	45	26.4	40	-	62
		18 H 075	18	72.77	71.39	79.0	55	26.4	40	-	63
		19 H 075	19	76.81	75.44	82.5	60	26.4	40	11	64
		20 H 075	20	80.85	79.48	87.0	62	26.4	40	11	76
		21 H 075	21	84.89	83.52	91.0	65	26.4	40	11	66
		22 H 075	22	88.93	87.56	94.0	68	26.4	40	11	67
		23 H 075	23	92.98	91.61	97.0	72	26.4	40	11	68
		24 H 075	24	97.03	95.65	102.0	72	26.4	40	11	70
		25 H 075	25	101.06	99.69	106.0	72	26.4	40	11	71
		26 H 075	26	105.11	103.73	112.0	80	26.4	40	11	72
		27 H 075	27	109.15	107.78	115.0	80	26.4	40	11	74
		28 H 075	28	113.18	111.82	120.0	80	26.4	40	11	75
		30 H 075	30	121.29	119.90	128.0	80	26.4	40	11	78
		32 H 075	32	129.30	127.99	135.0	80	26.4	40	11	80
		33 H 075	33	133.40	132.03	142.0	80	26.4	40	11	81
		34 H 075	34	137.45	136.07	142.0	80	26.4	40	11	81
		35 H 075	35	141.49	140.12	150.0	80	26.4	40	11	85
36 H 075	36	145.54	144.16	150.0	80	26.4	40	11	85		
38 H 075	38	153.62	152.24	158.0	80	26.4	40	11	86		
40 H 075	40	161.70	160.33	168.0	80	26.4	40	11	90		
42 H 075	42	169.79	168.41	184.0	80	26.4	40	11	94		
CAST-IRON	WITHOUT FLANGE	44 H 075	44	177.80	176.50	184.0	80	26.4	40	14	95
		48 H 075	48	194.03	192.67	200.0	90	26.4	45	14	100
		50 H 075	4	50	202.13	200.75	-	90	26.4	45	14

POWERGRIP® TOOTHED PULLEYS FOR SYNCHRONOUS BELTS

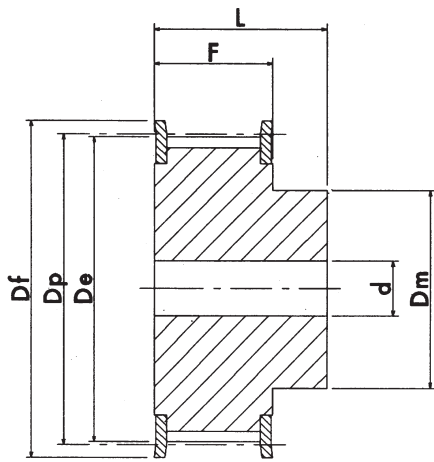

esecuzione 1F

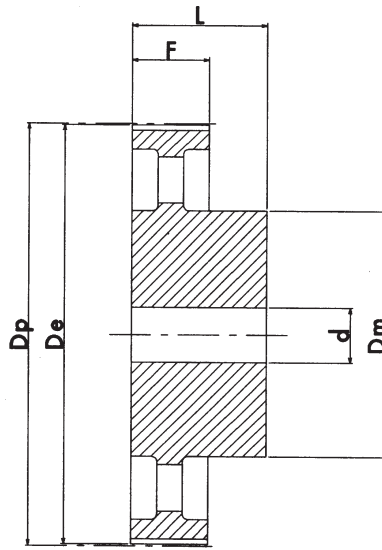

esecuzione 4

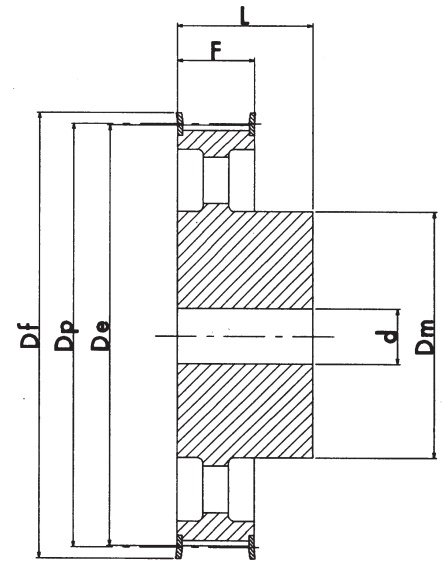

esecuzione 5F

H 100 PITCH 1/2" (12.7 mm.)

CHARACTERISTICS	TYPE	EXEC.	No. of TEETH	Dp PITCH LINE	De EXTERNAL	Df FLANGE	Dm HUB	F	L	d	FLANGE No.			
STEEL	WITH FLANGE	14 H 100	1F	14	56.59	55.22	64.0	40	31.8	45	-	59		
		15 H 100	1F	15	60.64	59.27	66.5	45	31.8	45	-	60		
		16 H 100	1F	16	64.67	63.31	70.0	45	31.8	45	-	61		
		17 H 100	1F	17	68.72	67.35	75.0	45	31.8	45	-	62		
		18 H 100	1F	18	72.77	71.39	79.0	55	31.8	45	-	63		
		19 H 100	1F	19	76.81	75.44	82.5	60	31.8	45	14	64		
		20 H 100	1F	20	80.85	79.48	87.0	62	31.8	45	14	76		
		21 H 100	1F	21	84.89	83.52	91.0	65	31.8	45	14	66		
		22 H 100	1F	22	88.93	87.56	94.0	68	31.8	45	14	67		
		23 H 100	1F	23	92.98	91.61	97.0	72	31.8	45	14	68		
		24 H 100	1F	24	97.03	95.65	102.0	72	31.8	45	14	70		
		25 H 100	1F	25	101.06	99.69	106.0	72	31.8	45	14	71		
		26 H 100	1F	26	105.11	103.73	112.0	80	31.8	45	14	72		
		27 H 100	1F	27	109.15	107.78	115.0	80	31.8	45	14	74		
		28 H 100	1F	28	113.18	111.82	120.0	80	31.8	45	14	75		
		29 H 100	1F	29	117.23	115.86	120.0	80	31.8	45	14	75		
		30 H 100	1F	30	121.29	119.90	128.0	80	31.8	45	14	78		
		32 H 100	1F	32	129.30	127.99	135.0	80	31.8	45	14	80		
		33 H 100	1F	33	133.40	132.03	142.0	80	31.8	45	14	81		
		34 H 100	1F	34	137.45	136.07	142.0	80	31.8	45	14	81		
		35 H 100	1F	35	141.49	140.12	150.0	80	31.8	45	14	85		
		36 H 100	1F	36	145.54	144.16	150.0	80	31.8	45	14	85		
		38 H 100	1F	38	153.62	152.24	158.0	80	31.8	45	14	86		
		40 H 100	1F	40	161.70	160.33	168.0	80	31.8	45	14	90		
		42 H 100	1F	42	169.79	168.41	180.0	80	31.8	45	14	94		
		CAST-IRON	WITH FLANGE	44 H 100	5F	44	177.88	176.50	184.0	80	31.8	50	14	95
				45 H 100	5F	45	181.91	180.54	192.0	80	31.8	50	14	96
				48 H 100	5F	48	194.03	192.67	200.0	90	31.8	50	14	100
WITHOUT FLANGE	50 H 100		4	50	202.13	200.75	-	90	31.8	50	19	-		
	52 H 100		4	52	210.21	208.84	-	90	31.8	50	19	-		
	58 H 100		4	58	234.47	233.09	-	90	31.8	50	19	-		
	60 H 100		4	60	242.55	241.18	-	120	31.8	50	19	-		
	70 H 100		4	70	282.98	281.61	-	120	31.8	55	19	-		
	72 H 100		4	72	291.06	289.69	-	120	31.8	55	19	-		
	84 H 100		4	84	339.57	338.20	-	120	31.8	55	19	-		
	96 H 100		4	96	388.09	386.71	-	120	31.8	60	19	-		
	120 H 100		4	120	485.12	483.73	-	120	31.8	60	19	-		

POWERGRIP® TOOTHED PULLEYS FOR SYNCHRONOUS BELTS

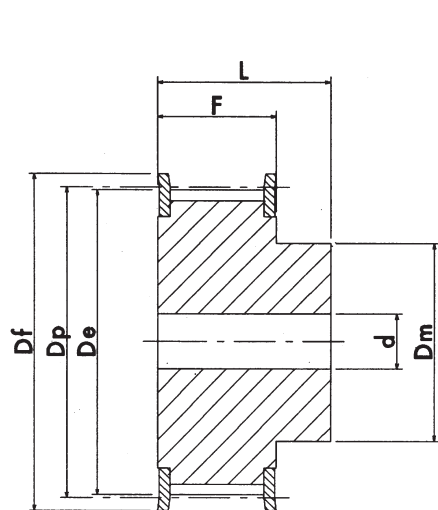

esecuzione 1F

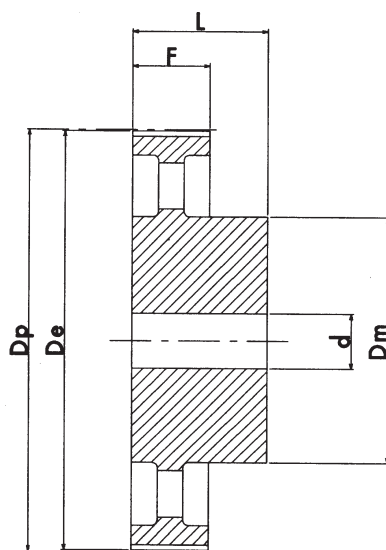

esecuzione 4

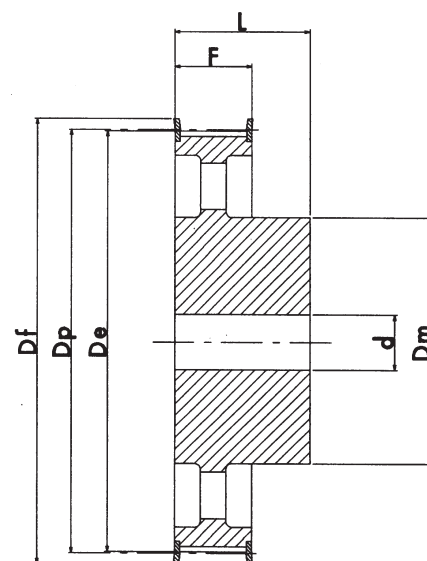

esecuzione 5F

H 150 PITCH 1/2" (12.7 mm.)

CARATTERISTICHE	TYPE	EXEC.	No. of TEETH	Dp PITCH LINE	De EXTERNAL	Df FLANGE	Dm HUB	F	L	d	FLANGE No.			
STEEL	WITH FLANGE	14 H 150	14	56.59	55.22	64.0	42	46.0	58	-	59			
		15 H 150	15	60.64	59.27	66.5	45	46.0	58	-	60			
		16 H 150	16	64.67	63.31	70.0	45	46.0	58	-	61			
		17 H 150	17	68.72	67.35	75.0	45	46.0	58	-	62			
		18 H 150	18	72.77	71.39	79.0	55	46.0	58	-	63			
		19 H 150	19	76.81	75.44	82.5	60	46.0	58	-	64			
		20 H 150	20	80.85	79.48	87.0	62	46.0	58	-	76			
		21 H 150	21	84.89	83.52	91.0	65	46.0	58	-	66			
		22 H 150	22	88.93	87.56	94.0	68	46.0	58	-	67			
		23 H 150	23	92.98	91.61	97.0	72	46.0	58	-	68			
		24 H 150	24	97.03	95.65	102.0	72	46.0	58	-	70			
		25 H 150	25	101.06	99.69	106.0	72	46.0	58	-	71			
		26 H 150	26	105.11	103.73	112.0	80	46.0	58	-	72			
		27 H 150	27	109.15	107.78	115.0	80	46.0	58	-	74			
		28 H 150	28	113.18	111.82	120.0	80	46.0	58	-	75			
		29 H 150	29	117.23	115.86	120.0	80	46.0	58	-	75			
		30 H 150	30	121.29	119.90	128.0	80	46.0	58	-	78			
		32 H 150	32	129.30	127.99	135.0	80	46.0	58	-	80			
		33 H 150	33	133.40	132.03	142.0	80	46.0	58	-	81			
		34 H 150	34	137.45	136.07	142.0	80	46.0	58	-	81			
		35 H 150	35	141.49	140.12	150.0	80	46.0	58	-	85			
		36 H 150	36	145.54	144.16	150.0	80	46.0	58	-	85			
		38 H 150	38	153.62	152.24	158.0	80	46.0	58	-	86			
		40 H 150	40	161.70	160.33	168.0	80	46.0	58	-	90			
		42 H 150	42	169.79	168.41	180.0	80	46.0	58	-	94			
		CAST-IRON	WITHOUT FLANGE	44 H 150	5F	44	177.88	176.50	184.00	80	46.0	58	19	95
				45 H 150	5F	45	181.91	180.54	192.00	80	46.0	58	19	96
				48 H 150	5F	48	194.03	192.67	200.00	90	46.0	65	19	100
				50 H 150	4	50	202.13	200.75	-	90	46.0	65	19	-
				52 H 150	4	52	210.21	208.84	-	90	46.0	65	19	-
				58 H 150	4	58	234.47	233.09	-	90	46.0	65	19	-
				60 H 150	4	60	242.55	241.18	-	120	46.0	65	19	-
				70 H 150	4	70	282.98	281.61	-	120	46.0	65	24	-
				72 H 150	4	72	291.06	289.69	-	120	46.0	65	24	-
				84 H 150	4	84	339.57	338.20	-	120	46.0	65	24	-
		96 H 150	4	96	388.09	386.71	-	120	46.0	65	24	-		
		120 H 150	4	120	485.12	483.73	-	120	46.0	65	24	-		

POWERGRIP® TOOTHED PULLEYS FOR SYNCHRONOUS BELTS

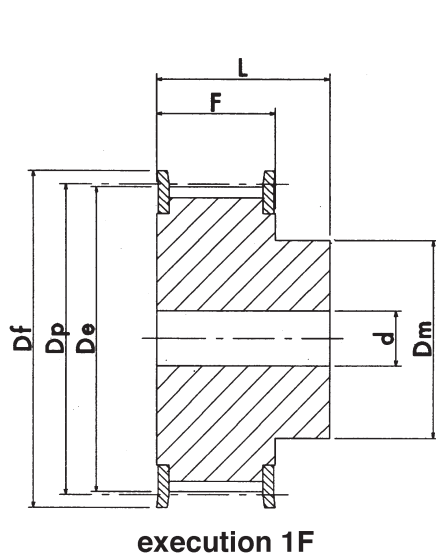

execution 1F

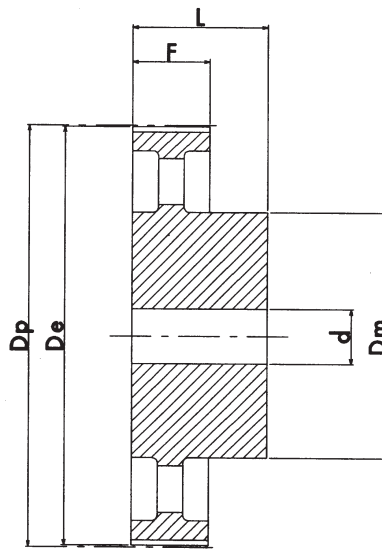

execution 4

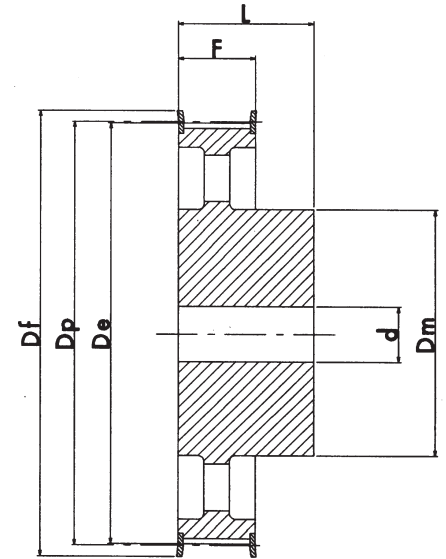

execution 5F

H 200 PITCH 1/2" (12.7 mm.)

CHARACTERISTICS	TYPE	EXEC.	No. of TEETH	Dp PITCH LINE	De EXTERNAL	Df FLANGE	Dm HUB	F	L	d	FLANGE No.	
STEEL	WITH FLANGE	14 H 200	1F	14	56.59	55.22	64.0	42	58.7	70	-	59
		15 H 200	1F	15	60.64	59.27	66.5	45	58.7	70	-	60
		16 H 200	1F	16	64.67	63.31	70.0	45	58.7	70	-	61
		17 H 200	1F	17	68.72	67.35	75.0	45	58.7	70	-	62
		18 H 200	1F	18	72.77	71.39	79.0	55	58.7	70	-	63
		19 H 200	1F	19	76.81	75.44	82.5	60	58.7	70	-	64
		20 H 200	1F	20	80.85	79.48	87.0	62	58.7	70	-	76
		21 H 200	1F	21	84.89	83.52	91.0	65	58.7	70	-	66
		22 H 200	1F	22	88.93	87.56	94.0	68	58.7	70	-	67
		23 H 200	1F	23	92.98	91.61	97.0	72	58.7	70	-	68
		24 H 200	1F	24	97.03	95.65	102.0	72	58.7	70	-	70
		25 H 200	1F	25	101.06	99.69	106.0	72	58.7	70	-	71
		26 H 200	1F	26	105.11	103.73	112.0	80	58.7	70	-	72
		27 H 200	1F	27	109.15	107.78	115.0	80	58.7	70	-	74
		28 H 200	1F	28	113.18	111.82	120.0	80	58.7	70	-	75
		29 H 200	1F	29	117.23	115.86	120.0	80	58.7	70	-	75
		30 H 200	1F	30	121.29	119.90	128.0	80	58.7	70	-	78
		32 H 200	1F	32	129.30	127.99	135.0	80	58.7	70	-	80
		33 H 200	1F	33	133.40	132.03	142.0	80	58.7	70	-	81
		34 H 200	1F	34	137.45	136.07	142.0	80	58.7	70	-	81
		35 H 200	1F	35	141.49	140.12	150.0	80	58.7	70	-	85
		36 H 200	1F	36	145.54	144.16	150.0	80	58.7	70	-	85
		38 H 200	1F	38	153.62	152.24	158.0	80	58.7	70	-	86
		40 H 200	1F	40	161.70	160.33	168.0	80	58.7	70	-	90
42 H 200	1F	42	169.79	168.41	180.0	80	58.7	70	-	94		
CAST-IRON	WITH FLANGE	44 H 200	5F	44	177.88	176.50	184.0	80	58.7	70	19	95
		45 H 200	5F	45	181.91	180.54	192.0	80	58.7	70	19	96
		48 H 200	5F	48	194.03	192.67	200.0	90	58.7	75	24	100
	WITHOUT FLANGE	50 H 200	4	50	202.13	200.75	-	90	58.7	75	24	-
		52 H 200	4	52	210.21	208.84	-	90	58.7	75	24	-
		58 H 200	4	58	234.47	233.09	-	90	58.7	75	24	-
		60 H 200	4	60	242.55	241.18	-	120	58.7	75	24	-
		70 H 200	4	70	282.98	281.61	-	120	58.7	75	28	-
		72 H 200	4	72	291.06	289.69	-	120	58.7	75	28	-
		84 H 200	4	84	339.57	338.20	-	120	58.7	75	28	-
		96 H 200	4	96	388.09	386.71	-	120	58.7	75	28	-
		120 H 200	4	120	485.12	483.73	-	120	58.7	75	28	-

POWERGRIP® TOOTHED PULLEYS FOR SYNCHRONOUS BELTS

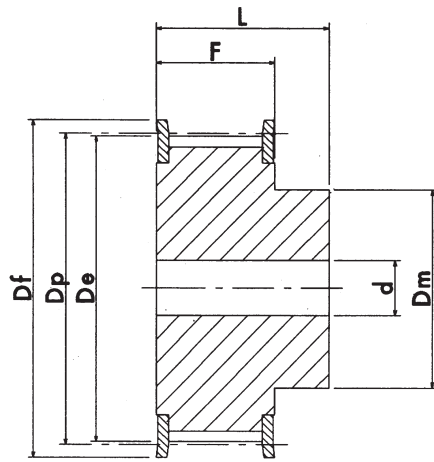

execution 1F

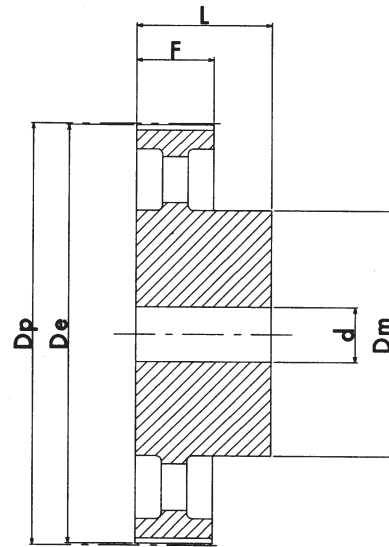

execution 4

TIPO: H 300 PASSO 1/2" (12.7 mm.)

CHARACTERISTICS	TYPE	EXEC.	No. of TEETH	Dp PITCH LINE	De EXTERNAL	Df FLANGE	Dm HUB	F	L	d	FLANGE No.	
STEEL	WITH FLANGE	14 H 300	1F	14	56.59	55.22	64.0	42	85.7	100	-	59
		15 H 300	1F	15	60.64	59.27	66.5	45	85.7	100	-	60
		16 H 300	1F	16	64.67	63.31	70.0	45	85.7	100	-	61
		17 H 300	1F	17	68.72	67.35	75.0	45	85.7	100	-	62
		18 H 300	1F	18	72.77	71.39	79.0	55	85.7	100	-	63
		19 H 300	1F	19	76.81	75.44	82.5	60	85.7	100	-	64
		20 H 300	1F	20	80.85	79.48	87.0	62	85.7	100	-	76
		21 H 300	1F	21	84.89	83.52	91.0	65	85.7	100	-	66
		22 H 300	1F	22	88.93	87.56	94.0	68	85.7	100	-	67
		23 H 300	1F	23	92.98	91.61	97.0	72	85.7	100	-	68
		24 H 300	1F	24	97.03	95.65	102.0	72	85.7	100	-	70
		25 H 300	1F	25	101.06	99.69	106.0	72	85.7	100	-	71
		26 H 300	1F	26	105.11	103.73	112.0	80	85.7	100	-	72
		27 H 300	1F	27	109.15	107.78	115.0	80	85.7	100	-	74
		28 H 300	1F	28	113.18	111.82	120.0	80	85.7	100	-	75
		30 H 300	1F	30	121.29	119.90	128.0	80	85.7	100	-	78
		32 H 300	1F	32	129.30	127.99	135.0	80	85.7	100	-	80
		33 H 300	1F	33	133.40	132.03	142.0	80	85.7	100	-	81
		34 H 300	1F	34	137.45	136.07	142.0	80	85.7	100	-	81
		35 H 300	1F	35	141.49	140.12	150.0	80	85.7	100	-	85
36 H 300	1F	36	145.54	144.16	150.0	80	85.7	100	-	85		
38 H 300	1F	38	153.62	152.24	158.0	80	85.7	100	-	86		
40 H 300	1F	40	161.70	160.33	168.0	80	85.7	100	-	90		
42 H 300	1F	42	169.79	168.41	180.0	80	85.7	100	-	94		
CAST-IRON	WITHOUT FLANGE	44 H 300	4	44	177.88	176.50	-	80	85.7	100	24	-
		48 H 300	4	48	194.03	192.67	-	90	85.7	100	24	-
		50 H 300	4	50	202.13	200.75	-	90	85.7	100	24	-
		58 H 300	4	58	234.47	233.09	-	90	85.7	100	24	-
		60 H 300	4	60	242.55	241.18	-	120	85.7	100	24	-
		72 H 300	4	72	291.06	289.69	-	120	85.7	100	28	-
		84 H 300	4	84	339.57	338.20	-	120	85.7	100	28	-
		96 H 300	4	96	388.09	386.71	-	120	85.7	100	28	-
		120 H 300	4	120	485.12	483.73	-	120	85.7	100	28	-

POWERGRIP® TOOTHED PULLEYS FOR SYNCHRONOUS BELTS

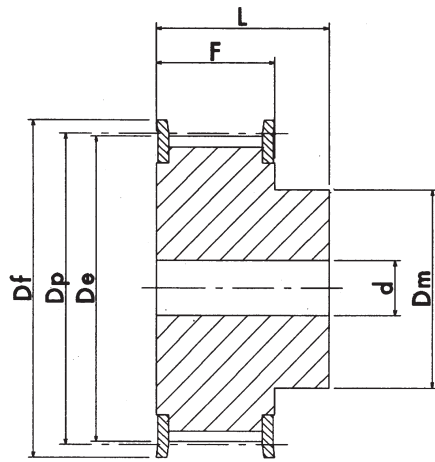

execution 1F

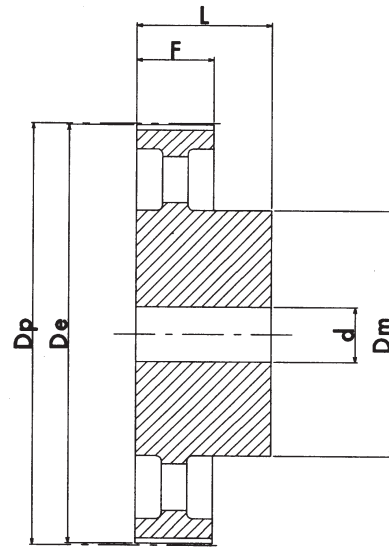

execution 4

* Toothings marked with an asterisk are produced on request

XH 200 PITCH 7/8" (22.22mm.)

CHARACTERISTICS		TYPE	EXEC.	No. of TEETH	Dp PITCH LINE	De EXTERNAL	Df FLANGE	Dm HUB	F	L	d	FLANGE No.
STEEL	WITH FLANGE	18 XH 200	1F	18	127.34	124.55	140.0	100	65	80	24	155
		19 XH 200	1F	19	134.41	131.62	146.0	100	65	80	24	156
		20 XH 200	1F	20	141.49	138.69	155.0	100	65	80	24	157
		21 XH 200	1F	21	148.56	145.77	160.0	110	65	80	24	158
		22 XH 200	1F	22	155.64	152.84	170.0	110	65	80	24	159
		24 XH 200	1F	24	169.79	166.99	184.0	120	65	80	24	161
		25 XH 200	1F	25	176.86	174.07	188.0	120	65	80	24	162
		26 XH 200	1F	26	183.93	181.14	198.0	120	65	80	24	163
		27 XH 200	1F	27	191.01	188.22	205.0	120	65	80	24	164
		28 XH 200	1F	28	198.09	195.29	212.0	120	65	80	24	165
		30 XH 200	1F	30	212.23	209.44	227.0	120	65	80	24	167
		32 XH 200	1F	32	226.38	223.59	240.0	120	65	80	24	169
		34 XH 200	1F	34	240.53	237.74	256.0	120	65	80	24	170
		CAST-IRON	WITHOUT FLANGE	*38 XH 200	4	38	268.83	266.03	-	150	65	80
*40 XH 200	4			40	282.98	280.18	-	150	65	100	28	-
*48 XH 200	4			48	339.57	336.78	-	150	65	100	28	-
*60 XH 200	4			60	424.47	421.67	-	150	65	100	28	-
*72 XH 200	4			72	509.36	506.56	-	160	65	100	28	-
*84 XH 200	4			84	594.25	591.46	-	160	65	100	28	-
*96 XH 200	4			96	679.15	676.35	-	160	65	100	28	-
*120 XH 200	4			120	848.93	846.14	-	160	65	100	28	-

POWERGRIP® TOOTHED PULLEYS FOR SYNCHRONOUS BELTS

XH 300 PITCH 7/8" (22.22mm.)

CHARACTERISTICS		TYPE	EXEC.	No. of TEETH	Dp PITCH LINE	De EXTERNAL	Df FLANGE	Dm HUB	F	L	d	FLANGE No.
STEEL	WITH FLANGE	18 XH 300	1F	18	127.34	124.55	140.0	100	90.5	110	28	155
		19 XH 300	1F	19	134.41	131.62	146.0	100	90.5	110	28	156
		20 XH 300	1F	20	141.49	138.69	155.0	100	90.5	110	28	157
		21 XH 300	1F	21	148.56	145.77	160.0	110	90.5	110	28	158
		22 XH 300	1F	22	155.64	152.84	170.0	110	90.5	110	28	159
		24 XH 300	1F	24	169.79	166.99	184.0	120	90.5	110	28	161
		25 XH 300	1F	25	176.86	174.07	188.0	120	90.5	110	28	162
		26 XH 300	1F	26	183.93	181.14	198.0	120	90.5	110	28	163
		27 XH 300	1F	27	191.01	188.22	205.0	120	90.5	110	28	164
		28 XH 300	1F	28	198.09	195.29	212.0	150	90.5	110	28	165
		30 XH 300	1F	30	212.23	209.44	227.0	150	90.5	110	28	167
		32 XH 300	1F	32	226.38	223.59	240.0	150	90.5	110	28	169
		34 XH 300	1F	34	240.53	237.74	256.0	150	90.5	110	28	170
		CAST-IRON	WITHOUT FLANGE	*38 XH 300	4	38	268.83	266.03	-	150	90.5	120
*40 XH 300	4			40	282.98	280.18	-	150	90.5	120	32	-
*48 XH 300	4			48	339.57	336.78	-	175	90.5	120	32	-
*60 XH 300	4			60	424.47	421.67	-	175	90.5	120	32	-
*72 XH 300	4			72	509.36	506.56	-	175	90.5	120	32	-
*84 XH 300	4			84	594.25	591.46	-	175	90.5	120	32	-
*96 XH 300	4			96	679.15	676.35	-	175	90.5	120	32	-
*120 XH 300	4			120	848.93	846.14	-	175	90.5	120	32	-

* Tothing marked with an asterisk are produced on request

XH 400 PITCH 7/8" (22.22mm.)

CHARACTERISTICS		TYPE	EXEC.	No. of TEETH	Dp PITCH LINE	De EXTERNAL	Df FLANGE	Dm HUB	F	L	d	FLANGE No.
STEEL	WITH FLANGE	18 XH 400	1F	18	127.34	124.55	140.0	100	118	132	32	155
		19 XH 400	1F	19	134.41	131.62	146.0	100	118	132	32	156
		20 XH 400	1F	20	141.49	138.69	155.0	100	118	132	32	157
		21 XH 400	1F	21	148.56	145.77	160.0	110	118	132	32	158
		22 XH 400	1F	22	155.64	152.84	170.0	110	118	132	32	159
		24 XH 400	1F	24	169.79	166.99	184.0	120	118	132	32	161
		25 XH 400	1F	25	176.86	174.07	188.0	120	118	132	32	162
		26 XH 400	1F	26	183.93	181.14	198.0	120	118	132	32	163
		27 XH 400	1F	27	191.01	188.22	205.0	120	118	132	32	164
		28 XH 400	1F	28	198.09	195.29	212.0	150	118	132	32	165
		30 XH 400	1F	30	212.23	209.44	227.0	150	118	132	32	167
		32 XH 400	1F	32	226.38	223.59	240.0	150	118	132	32	169
		34 XH 400	1F	34	240.53	237.74	256.0	150	118	132	32	170
		CAST-IRON	WITHOUT FLANGE	*38 XH 400	4	38	268.83	266.03	-	150	118	132
*40 XH 400	4			40	282.98	280.18	-	150	118	132	32	-
*48 XH 400	4			48	339.57	336.78	-	175	118	132	32	-
*60 XH 400	4			60	424.47	421.67	-	175	118	132	32	-
*72 XH 400	4			72	509.36	506.56	-	175	118	132	32	-
*84 XH 400	4			84	594.25	591.46	-	175	118	132	32	-
*96 XH 400	4			96	679.15	676.35	-	175	118	132	32	-
*120 XH 400	4			120	848.93	846.14	-	175	118	132	32	-

POWERGRIP® TOOTHED PULLEYS FOR SYNCHRONOUS BELTS

XXH 200 PITCH 1" 1/4 (31.75mm.)

CHARACTERISTICS		TYPE	EXEC.	No. of TEETH	Dp PITCH LINE	De EXTERNAL	Df FLANGE	Dm HUB	F	L	d	FLANGE No.
STEEL	WITH FLANGE	18 XXH 200	1F	18	181.91	178.87	198.0	140	64.2	100	28	163
		20 XXH 200	1F	20	202.13	199.08	212.0	150	64.2	100	28	165
		22 XXH 200	1F	22	222.34	219.29	240.0	150	64.2	100	28	169
		24 XXH 200	1F	24	242.55	239.50	267.0	150	64.2	100	28	173
		26 XXH 200	1F	26	262.76	259.79	290.0	150	64.2	100	28	178
CAST-IRON	WITHOUT FLANGE	*30 XXH 200	4	30	303.19	300.14	-	150	64.2	100	28	-
		*40 XXH 200	4	40	404.25	401.21	-	150	64.2	100	28	-
		*48 XXH 200	4	48	485.10	482.06	-	175	64.2	120	32	-
		*60 XXH 200	4	60	606.38	603.33	-	175	64.2	120	32	-
		*72 XXH 200	4	72	727.66	724.61	-	175	64.2	120	38	-
		*90 XXH 200	4	90	909.57	906.52	-	175	64.2	120	38	-

* Toothings marked with the asterisk are produced on request

XXH 300 PITCH 1" 1/4 (mm 31.75)

CHARACTERISTICS		TYPE	EXEC.	No. of TEETH	Dp PITCH LINE	De EXTERNAL	Df FLANGE	Dm HUB	F	L	d	FLANGE No.
STEEL	WITH FLANGE	18 XXH 300	1F	18	181.91	178.87	198.0	140	91.4	110	28	163
		20 XXH 300	1F	20	202.13	199.08	212.0	150	91.4	110	28	165
		22 XXH 300	1F	22	222.34	219.29	240.0	150	91.4	110	28	169
		24 XXH 300	1F	24	242.55	239.50	267.0	150	91.4	110	28	173
		26 XXH 300	1F	26	262.76	259.79	290.0	150	91.4	110	28	178
CAST-IRON	WITHOUT FLANGE	*30 XXH 300	4	30	303.19	300.14	-	150	91.4	110	28	-
		*40 XXH 300	4	40	404.25	401.21	-	150	91.4	110	28	-
		*48 XXH 300	4	48	485.10	482.06	-	175	91.4	120	32	-
		*60 XXH 300	4	60	606.38	603.33	-	175	91.4	120	32	-
		*72 XXH 300	4	72	727.66	724.61	-	175	91.4	120	38	-
		*90 XXH 300	4	90	909.57	906.52	-	175	91.4	120	38	-

POWERGRIP® TOOTHED PULLEYS FOR SYNCHRONOUS BELTS

XXH 400 PITCH 1" 1/4 (31.75mm.)

CHARACTERISTICS		TYPE	EXEC.	No. of TEETH	Dp PITCH LINE	De EXTERNAL	Df FLANGE	Dm HUB	F	L	d	FLANGE No.
STEEL	WITH FLANGE	18 XXH 400	1F	18	181.91	178.87	198.0	140	118.2	140	32	163
		20 XXH 400	1F	20	202.13	199.08	212.0	150	118.2	140	32	165
		22 XXH 400	1F	22	222.34	219.29	240.0	150	118.2	140	32	169
		24 XXH 400	1F	24	242.55	239.50	267.0	150	118.2	140	32	173
		26 XXH 400	1F	26	262.76	259.79	290.0	150	118.2	140	32	178
CAST-IRON	WITHOUT FLANGE	*30 XXH 400	4	30	303.19	300.14	-	185	118.2	140	32	-
		*40 XXH 400	4	40	404.25	401.21	-	185	118.2	140	32	-
		*48 XXH 400	4	48	485.10	482.06	-	185	118.2	140	38	-
		*60 XXH 400	4	60	606.38	603.33	-	185	118.2	140	38	-
		*72 XXH 400	4	72	727.66	724.61	-	220	118.2	140	38	-
		*90 XXH 400	4	90	909.57	906.52	-	220	118.2	140	38	-

* Toothings marked with the asterisk are produced on request

XXH 500 PITCH 1" 1/4 (mm 31.75)

CHARACTERISTICS		TYPE	EXEC.	No. of TEETH	Dp PITCH LINE	De EXTERNAL	Df FLANGE	Dm HUB	F	L	d	FLANGE No.
STEEL	WITH FLANGE	18 XXH 500	1F	18	181.91	178.87	198.0	140	145.3	168	32	163
		20 XXH 500	1F	20	202.13	199.08	212.0	150	145.3	168	32	165
		22 XXH 500	1F	22	222.34	219.29	240.0	150	145.3	168	32	169
		24 XXH 500	1F	24	242.55	239.50	267.0	150	145.3	168	32	173
		26 XXH 500	1F	26	262.76	259.79	290.0	150	145.3	168	32	178
CAST-IRON	WITHOUT FLANGE	*30 XXH 500	4	30	303.19	300.14	-	215	145.3	168	32	-
		*40 XXH 500	4	40	404.25	401.21	-	215	145.3	168	32	-
		*48 XXH 500	4	48	485.10	482.06	-	215	145.3	168	38	-
		*60 XXH 500	4	60	606.38	603.33	-	240	145.3	168	38	-
		*72 XXH 500	4	72	727.66	724.61	-	240	145.3	168	38	-
		*90 XXH 500	4	90	909.57	906.52	-	240	145.3	168	38	-

POWERGRIP® TOOTHED PULLEYS FOR SYNCHRONOUS BELTS

EXPORT "PHOSPHATED"

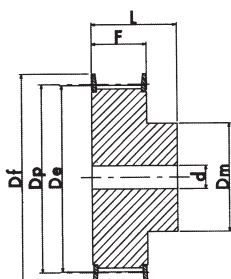

EXECUTION 1F

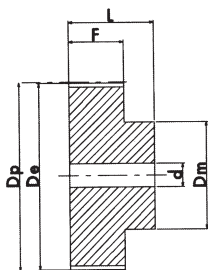

EXECUTION 2

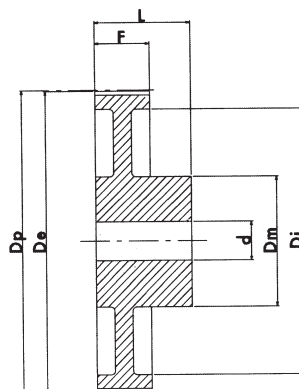

EXECUTION 3

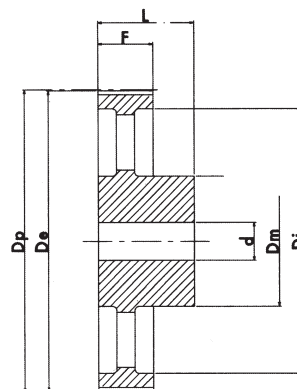

EXECUTION 4

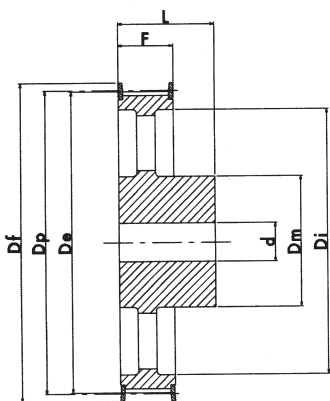

EXECUTION 5F

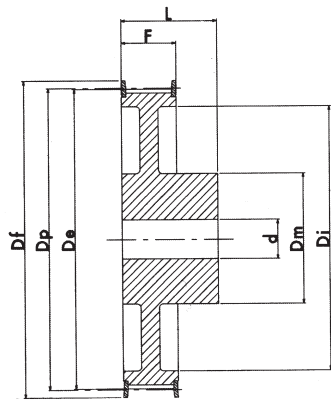

EXECUTION 6F

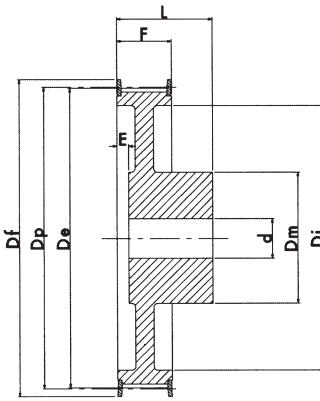

EXECUTION 7F

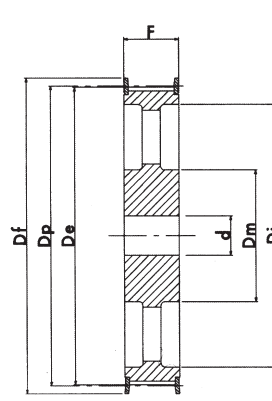

EXECUTION 8F

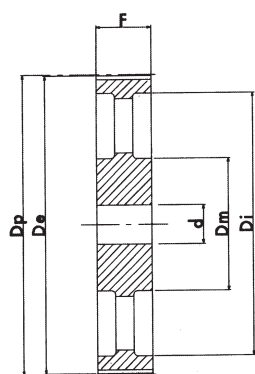

EXECUTION 9

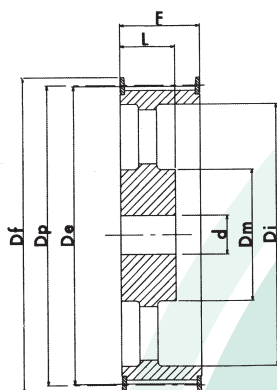

EXECUTION 10F

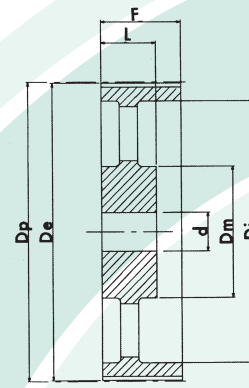

EXECUTION 11

POWERGRIP® TOOTHED PULLEYS FOR SYNCHRONOUS BELTS

EXPORT "PHOSPHATED"

XL 037 PITCH 1/5" (5.08mm.)

CHARACTERISTICS	TYPE	EXEC.	No. of TEETH	Dp PITCH LINE	De EXTERNAL	Df FLANGE	Dm HUB	Di	F	L	d Ø bore	No. 2 holes threaded at 90°	FLANGE No.	
STEEL/ALUMINIUM	WITH FLANGE	10 XL 037	1F	10	16.17	15.66	23	9.5	-	14.3	19.8	4.0	M3	1
		11 XL 037	1F	11	17.79	17.28	23	11.0	-	14.3	19.8	4.0	M3	1
		12 XL 037	1F	12	19.40	18.90	25	12.7	-	14.3	19.8	4.0	M3	2
		14 XL 037	1F	14	22.64	22.13	28	14.3	-	14.3	19.8	6.0	M4	4
		15 XL 037	1F	15	24.26	23.75	28	15.9	-	14.3	19.8	6.0	M4	4
		16 XL 037	1F	16	25.87	25.36	32	17.5	-	14.3	19.8	6.0	M4	5
		18 XL 037	1F	18	29.11	28.60	35	20.6	-	14.3	19.8	6.0	M4	7
		20 XL 037	1F	20	32.34	31.83	38	23.8	-	14.3	22.2	6.0	M4	9
		21 XL 037	1F	21	33.96	33.45	38	23.8	-	14.3	22.2	6.0	M4	9
		22 XL 037	1F	22	35.57	35.07	41	25.4	-	14.3	22.2	6.0	M4	10
		24 XL 037	1F	24	38.81	38.30	44	27.0	-	14.3	22.2	6.0	M4	12
		26 XL 037	1F	26	42.04	41.53	48	30.0	-	14.3	22.2	6.0	M4	11
		28 XL 037	1F	28	45.28	44.77	51	30.2	-	14.3	22.2	6.0	M4	16
		30 XL 037	1F	30	48.51	48.00	54	34.9	-	14.3	22.2	6.0	M4	18
ALUMINIUM	WITHOUT FLANGE	32 XL 037	2	32	51.74	51.24	-	38.0	-	14.3	25.4	8.0	M4	-
		36 XL 037	2	36	58.21	57.70	-	38.0	-	14.3	25.4	8.0	M4	-
		40 XL 037	2	40	64.68	64.17	-	38.0	-	14.3	25.4	8.0	M4	-
		42 XL 037	3	42	67.91	67.41	-	38.0	58	14.3	25.4	8.0	M4	-
		44 XL 037	3	44	71.15	70.64	-	38.0	60	14.3	25.4	8.0	M4	-
		48 XL 037	3	48	77.62	77.11	-	38.0	66	14.3	25.4	8.0	M4	-
		60 XL 037	3	60	97.02	96.51	-	38.0	82	14.3	25.4	8.0	M4	-
		72 XL 037	3	72	116.43	115.92	-	38.0	100	14.3	25.4	8.0	M4	-

L 050 PITCH 3/8" (9.52mm.)

CHARACTERISTICS	TYPE	TYPE	No. of TEETH	Dp PITCH LINE	De EXTERNAL	Df FLANGE	Dm HUB	Di	F	L	d Ø bore	FLANGE No.	
STEEL	WITH FLANGE	10 L 050	1F	10	30.32	29.56	37	22	-	19	26	6	50
		12 L 050	1F	12	36.38	35.62	43	28	-	19	26	6	52
		13 L 050	1F	13	39.41	38.65	44	30	-	19	26	6	83
		14 L 050	1F	14	42.45	41.68	48	33	-	19	26	8	54
		15 L 050	1F	15	45.48	44.72	51	36	-	19	26	8	55
		16 L 050	1F	16	48.51	47.75	54	38	-	19	26	8	56
		17 L 050	1F	17	51.54	50.78	57	40	-	19	26	10	57
		18 L 050	1F	18	54.57	53.81	60	40	-	19	26	10	58
		19 L 050	1F	19	57.61	56.84	64	40	-	19	26	10	59
		20 L 050	1F	20	60.64	59.88	66.5	46	-	19	26	10	60
		21 L 050	1F	21	63.67	62.91	70	46	-	19	26	10	61
		22 L 050	1F	22	66.70	65.94	75	50	-	19	26	10	62
		24 L 050	1F	24	72.77	72.00	79	50	-	19	26	12	63
		26 L 050	1F	26	78.83	78.07	86	50	-	19	26	12	65
		28 L 050	1F	28	84.89	84.13	91	50	-	19	26	12	66
		30 L 050	1F	30	90.96	90.20	97	50	-	19	26	12	68
		32 L 050	1F	32	97.02	96.26	102	50	-	19	26	12	70
		36 L 050	6F	36	109.15	108.39	115	50	94	19	26	12	74
40 L 050	6F	40	121.28	120.51	128	50	98	19	26	12	78		
CAST-IRON	WITH FLANGE	44 L 050	5F	44	133.40	132.64	142	50	108	19	26	12	81
		48 L 050	5F	48	145.53	144.77	150	50	118	19	26	12	85
	WITHOUT FLANGE	60 L 050	4	60	191.91	181.15	-	50	163	19	28	15	-
		72 L 050	4	72	218.30	217.53	-	50	199	19	28	15	-
		84 L 050	4	84	254.68	253.92	-	50	236	19	28	15	-

N.B. The aluminium pulleys are not phosphated

POWERGRIP® TOOTHED PULLEYS FOR SYNCHRONOUS BELTS

EXPORT "PHOSPHATED"

L 075 PITCH 3/8" (9.52mm.)

CHARACTERISTICS	TYPE	TYPE	No. of TEETH	Dp PITCH LINE	De EXTERNAL	Df FLANGE	Dm HUB	Di	F	L	d bore	FLANGE No.
STEEL	WITH FLANGE	1F	10	30.32	29.56	37	22	-	25	32	8	50
		1F	12	36.38	35.62	43	28	-	25	32	8	52
		1F	13	39.41	38.65	44	30	-	25	32	8	83
		1F	14	42.45	41.68	48	33	-	25	32	8	54
		1F	15	45.48	44.72	51	36	-	25	32	8	55
		1F	16	48.51	47.75	54	38	-	25	32	8	56
		1F	17	51.54	50.78	57	40	-	25	32	10	57
		1F	18	54.57	53.81	60	40	-	25.57	32	10	58
		1F	19	57.61	56.84	64	40	-	25	32	10	59
		1F	20	60.64	59.88	66.5	46	-	25	32	10	60
		1F	21	63.67	62.91	70	46	-	25	32	10	61
		1F	22	66.70	65.94	75	50	-	25	32	10	62
		1F	24	72.77	72.00	79	50	-	25	32	12	63
		1F	26	78.83	78.07	86	50	-	25	32	12	65
		1F	28	84.89	84.13	91	50	-	25	32	12	66
		1F	30	90.96	90.20	97	50	-	25	32	12	68
		1F	32	97.02	96.26	102	50	-	25	32	12	70
		6F	36	109.15	108.39	115	55	94	25	32	12	74
		6F	40	121.28	120.51	128	60	98	25	32	12	78
		CAST-IRON	WITH FLANGE	5F	44	133.40	132.64	142	60	108	25	32
5F	48			145.53	144.77	150	60	118	25	32	12	85
WITHOUT FLANGE	4		60	191.91	181.15	-	60	163	26	35	15	-
	4		70	218.30	217.53	-	60	199	26	35	15	-
	4		84	254.68	253.92	-	60	236	26	35	15	-

L 100 PITCH 3/8" (9.52mm.)

CHARACTERISTICS	TYPE	TYPE	No. of TEETH	Dp PITCH LINE	De EXTERNAL	Df FLANGE	Dm HUB	Di	F	L	d bore	FLANGE No.
STEEL	WITH FLANGE	1F	10	30.32	29.56	37	22	-	31	38	8	50
		1F	12	36.38	35.62	43	28	-	31	38	8	52
		1F	13	39.41	38.65	44	30	-	31	38	8	83
		1F	14	42.45	41.68	48	33	-	31	38	8	54
		1F	15	45.48	44.72	51	36	-	31	38	8	55
		1F	16	48.51	47.75	54	38	-	31	38	8	56
		1F	17	51.54	50.78	57	40	-	31	38	10	57
		1F	18	54.57	53.81	60	40	-	31	38	10	58
		1F	19	57.61	56.84	64	40	-	31	38	10	59
		1F	20	60.64	59.88	66.5	46	-	31	38	10	60
		1F	21	63.67	62.91	70	46	-	31	38	10	61
		1F	22	66.70	65.94	75	50	-	31	38	10	62
		1F	24	72.77	72.00	79	50	-	31	38	12	63
		1F	26	78.83	78.07	86	50	-	31	38	12	65
		1F	28	84.89	84.13	91	50	-	31	38	12	66
		1F	30	90.96	90.20	97	50	-	31	38	12	68
		1F	32	97.02	96.26	102	50	-	31	38	12	70
		7F	36	109.15	108.39	115	55	94	32	38	12	74
		7F	40	121.28	120.51	128	60	98	32	38	12	78
		CAST-IRON	WITH FLANGE	8F	44	133.40	132.64	142	60	108	32	-
8F	48			145.53	144.77	150	60	118	32	-	12	85
WITHOUT FLANGE	4		60	191.91	181.15	-	60	163	32	35	15	-
	4		72	218.30	217.53	-	60	199	32	35	15	-
	4		84	254.68	253.92	-	60	236	32	35	15	-

POWERGRIP® TOOTHED PULLEYS FOR SYNCHRONOUS BELTS

EXPORT "PHOSPHATED"

H 100 PITCH 1/2" (12.7mm.)

CHARACTERISTICS	TYPE	EXEC.	No. of TEETH	Dp PITCH LINE	De EXTERNAL	Df FLANGE	Dm HUB	Di	F	L	E	d Ø bore	FLANGE No.	
STEEL	WITH FLANGE	14 H 100	1F	14	56.60	55.22	64	40	-	31	41	-	10	59
		16 H 100	1F	16	64.68	63.31	70	46	-	31	41	-	10	61
		18 H 100	1F	18	72.77	71.39	79	54	-	31	41	-	12	63
		19 H 100	1F	19	76.81	75.44	82.5	58	-	31	41	-	12	64
		20 H 100	1F	20	80.85	79.48	87	62	-	31	41	-	12	76
		21 H 100	1F	21	84.89	83.52	91	67	-	31	41	-	12	66
		22 H 100	1F	22	88.94	87.56	94	70	-	31	41	-	12	67
		24 H 100	1F	24	97.02	95.65	102	75	-	31	41	-	12	70
		26 H 100	7F	26	105.11	103.73	112	55	81	32	40	8	15	72
		28 H 100	7F	28	113.19	111.82	115	60	88	32	40	8	15	75
		30 H 100	7F	30	121.28	119.90	128	60	97	32	40	8	15	78
		32 H 100	6F	32	129.36	127.99	135	70	105	32	40	-	20	80
36 H 100	6F	36	145.53	144.16	150	80	118	32	40	-	20	85		
CAST-IRON	WITH FLANGE	40 H 100	5F	40	161.70	160.33	168	80	135	32	40	-	20	90
		44 H 100	5F	44	177.87	176.50	184	80	150	32	40	-	20	95
		48 H 100	5F	48	194.04	192.67	200	80	170	32	40	-	20	100
	WITHOUT FLANGE	60 H 100	4	60	242.55	241.18	-	80	216	34	45	-	20	-
		72 H 100	4	72	291.06	289.69	-	80	263	34	45	-	20	-
		84 H 100	4	84	339.57	338.20	-	80	312	34	45	-	20	-
		96 H 100	4	96	388.08	386.71	-	80	360	34	45	-	20	-
		120 H 100	4	120	485.10	483.73	-	90	458	34	50	-	20	-

H 150 PITCH 1/2" (12.7mm.)

CHARACTERISTICS	TYPE	EXEC.	No. of TEETH	Dp PITCH LINE	De EXTERNAL	Df FLANGE	Dm HUB	Di	F	L	E	d Ø bore	FLANGE No.	
STEEL	WITH FLANGE	14 H 150	1F	14	56.60	55.22	64	40	-	44	54	-	12	59
		16 H 150	1F	16	64.68	63.31	70	46	-	44	54	-	12	61
		18 H 150	1F	18	72.77	71.39	79	54	-	44	54	-	12	63
		19 H 150	1F	19	76.81	75.44	82.5	58	-	44	54	-	12	64
		20 H 150	1F	20	80.85	79.48	87	62	-	44	54	-	12	76
		21 H 150	1F	21	84.89	83.52	91	67	-	44	54	-	12	66
		22 H 150	1F	22	88.94	87.56	94	70	-	44	54	-	12	67
		24 H 150	1F	24	97.02	95.65	102	75	-	44	54	-	12	70
		26 H 150	7F	26	105.11	103.73	112	55	81	45	53	18	15	72
		28 H 150	7F	28	113.19	111.82	115	60	88	45	53	18	15	75
		30 H 150	7F	30	121.28	119.90	128	60	97	45	53	18	15	78
		32 H 150	6F	32	129.36	127.99	135	70	105	45	53	-	20	80
36 H 150	6F	36	145.53	144.16	150	80	118	45	53	-	20	85		
CAST-IRON	WITH FLANGE	40 H 150	8F	40	161.7	160.33	168	80	135	45	-	-	20	90
		44 H 150	8F	44	177.87	176.50	184	80	150	45	-	-	20	95
		48 H 150	8F	48	194.04	192.67	200	80	170	45	-	-	20	100
	WITHOUT FLANGE	60 H 150	9	60	242.55	241.18	-	85	216	46	-	-	20	-
		72 H 150	9	72	291.06	289.69	-	85	263	46	-	-	20	-
		84 H 150	9	84	339.57	338.20	-	85	312	46	-	-	20	-
		96 H 150	9	96	388.08	386.71	-	85	360	46	-	-	20	-
		120 H 150	4	120	485.10	483.73	-	95	458	46	55	-	24	-

POWERGRIP® TOOTHED PULLEYS FOR SYNCHRONOUS BELTS

EXPORT "PHOSPHATED"

H 200 PITCH 1/2" (12.7mm.)

CHARACTERISTICS	TYPE	EXEC.	No. of TEETH	Dp PITCH LINE	De EXTERNAL	Df FLANGE	Dm HUB	Di	F	L	E	d Ø bore	FLANGE No.	
STEEL	WITH FLANGE	14 H 200	1F	14	56.60	55.22	64	40	-	58	68	-	-	59
		16 H 200	1F	16	64.68	63.31	70	46	-	58	68	-	-	61
		18 H 200	1F	18	71.77	71.39	79	54	-	58	68	-	-	63
		19 H 200	1F	19	76.81	75.44	82.5	58	-	58	68	-	-	64
		20 H 200	1F	20	80.85	79.48	87	62	-	58	68	-	-	76
		21 H 200	1F	21	84.89	83.52	91	67	-	58	68	-	-	66
		22 H 200	1F	22	88.94	87.56	94	70	-	58	68	-	-	67
		24 H 200	1F	24	97.02	95.65	102	75	-	58	68	-	-	70
		26 H 200	7F	26	105.11	103.73	112	60	81	58	66	24	15	72
		28 H 200	7F	28	113.19	111.82	115	60	88	58	66	24	15	75
		30 H 200	7F	30	121.28	119.90	128	70	97	58	66	24	15	78
		32 H 200	7F	32	129.36	127.99	135	70	105	58	66	19	20	80
36 H 200	7F	36	145.53	144.16	150	80	118	58	66	19	20	85		
CAST-IRON	WITH FLANGE	40 H 200	10F	40	161.70	160.33	168	80	135	58	45	-	20	90
		44 H 200	10F	44	177.87	176.50	184	80	150	58	45	-	20	95
		48 H 200	10F	48	194.04	192.67	200	80	170	58	45	-	20	100
	WITHOUT FLANGE	60 H 200	11	60	242.55	241.18	-	90	216	60	50	-	20	-
		72 H 200	11	72	291.06	289.69	-	90	263	60	50	-	20	-
		84 H 200	11	84	339.57	338.20	-	90	312	60	50	-	20	-
		96 H 200	11	96	388.08	386.71	-	90	360	60	50	-	20	-
		120 H 200	9	120	485.10	483.73	-	100	458	60	-	-	24	-

H 300 PITCH 1/2" (12.7mm.)

CHARACTERISTICS	TYPE	EXEC.	No. of TEETH	Dp PITCH LINE	De EXTERNAL	Df FLANGE	Dm HUB	Di	F	L	E	d Ø bore	FLANGE No.	
STEEL	WITH FLANGE	16 H 300	1F	16	64.68	63.31	70	46	-	84	94	-	-	61
		18 H 300	1F	18	71.77	71.39	79	54	-	84	94	-	-	63
		19 H 300	1F	19	76.81	75.44	82.5	58	-	84	94	-	-	64
		20 H 300	1F	20	80.85	79.48	87	62	-	84	94	-	-	76
		21 H 300	1F	21	84.89	83.52	91	67	-	84	94	-	-	66
		22 H 300	1F	22	88.94	87.56	94	70	-	84	94	-	-	67
		24 H 300	1F	24	97.02	95.65	102	75	-	84	94	-	-	70
		26 H 300	7F	26	105.11	103.73	112	60	81	84	92	35	15	72
		28 H 300	7F	28	113.19	111.82	115	60	88	84	92	35	15	75
		30 H 300	7F	30	121.28	119.90	128	70	97	84	92	35	15	78
		32 H 300	7F	32	129.36	127.99	135	70	105	84	92	35	20	80
		36 H 300	7F	36	145.53	144.16	150	80	118	84	92	35	20	85
CAST-IRON	WITH FLANGE	40 H 300	10F	40	161.70	160.33	168	80	135	84	55	-	20	90
		44 H 300	10F	44	177.87	176.50	184	80	150	84	55	-	20	95
		48 H 300	10F	48	194.04	192.67	200	85	170	84	55	-	20	100
	WITHOUT FLANGE	60 H 300	11	60	242.55	241.18	-	100	216	86	55	-	20	-
		72 H 300	11	72	291.06	289.69	-	100	263	86	55	-	20	-
		84 H 300	11	84	339.57	338.20	-	100	312	86	55	-	20	-
		96 H 300	11	96	388.08	386.71	-	100	360	86	55	-	20	-
		120 H 300	11	120	485.10	483.73	-	110	458	86	65	-	24	-

TAPER-LOCK® PULLEYS "PHOSPHATED"

Materials used for construction:

Steel: C 40 UNI 7845

Cast iron: G 20 UNI 5007

How to interpret the code reference:

TL 30 L 100 { TL Taper Lock®
30 No. of teeth
L belt pitch
100 belt width in inches

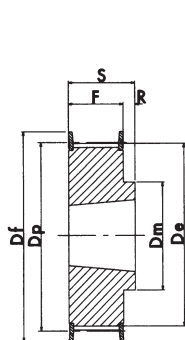

EXECUTION 1F

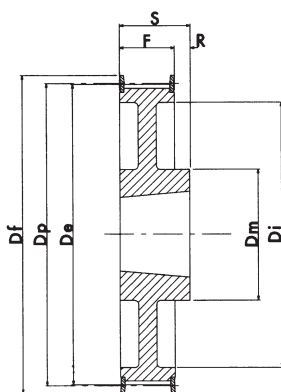

EXECUTION 2F

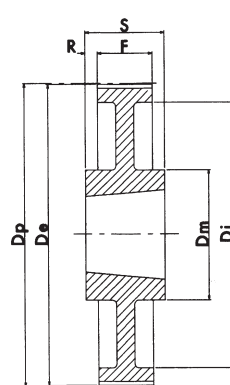

EXECUTION 3

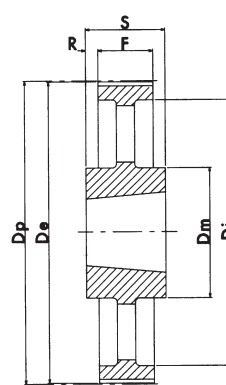

EXECUTION 4

L 050 PITCH 3/8" (9.52mm.)

CHARACTERISTICS	TYPE	EXEC.	BUSH	MAX BORE	Dp PITCH LINE	De EXTERNAL	D FLANGE	Dm HUB	Di	F	S	R	FLANGE	
													No.	
STEEL	WITH FLANGE	TL 18 L 050	1F	1108	28	54.57	53.81	60	45	-	19.0	22.0	3	58
		TL 19 L 050	1F	1108	28	57.61	56.84	64	45	-	19.0	22.0	3	59
		TL 20 L 050	1F	1108	28	60.64	59.88	66.5	48	-	19.0	22.0	3	60
		TL 21 L 050	1F	1108	28	63.67	62.91	70	48	-	19.0	22.0	3	61
		TL 22 L 050	1F	1108	28	66.70	65.94	75	51	-	19.0	22.0	3	62
		TL 23 L 050	1F	1108	28	69.73	68.97	79	54	-	19.0	22.0	3	63
		TL 24 L 050	1F	1108	28	72.77	72.00	79	54	-	19.0	22.0	3	63
		TL 25 L 050	1F	1108	28	75.80	75.04	82.5	56	-	19.0	22.0	3	64
		TL 26 L 050	1F	1108	28	78.83	78.07	86	60	-	19.0	22.0	3	65
		TL 27 L 050	1F	1108	28	81.86	81.10	86	62	-	19.0	22.0	3	65
		TL 28 L 050	1F	1108	28	84.89	84.13	91	65	-	19.0	22.0	3	66
		TL 30 L 050	1F	1108	28	90.96	90.20	97	70	-	19.0	22.0	3	68
		TL 32 L 050	1F	1108	28	97.02	96.26	102	74	-	19.0	22.0	3	70
		TL 36 L 050	1F	1108	28	109.15	108.39	115	85	-	19.0	22.0	3	74
		TL 40 L 050	1F	1610	42	121.28	120.51	128	97	-	19.0	25.0	6	78
		TL 44 L 050	2F	1610	42	133.40	132.64	142	88	110	19.0	25.0	6	81
TL 48 L 050	2F	1610	42	145.53	147.77	150	88	120	19.0	25.0	6	85		
CAST-IRON	WITHOUT FLANGE	TL 60 L 050	3	1610	42	181.91	181.15	-	92	166	19.0	25.0	3	-
		TL 72 L 050	4	1610	42	218.30	217.53	-	92	202	19.0	25.0	3	-
		TL 84 L 050	4	1610	42	254.68	253.90	-	92	236	19.0	25.0	3	-
		TL 96 L 050	4	2012	50	291.06	290.30	-	106	270	19.0	32.0	6.5	-
		TL 120 L 050	4	2012	50	363.83	363.07	-	106	343	19.0	32.0	6.5	-

TAPER-LOCK® PULLEYS " PHOSPHATED "

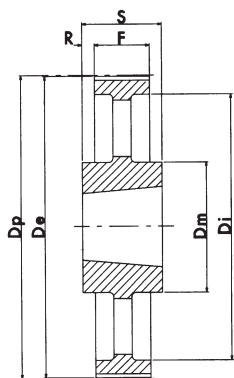

EXECUTION 4

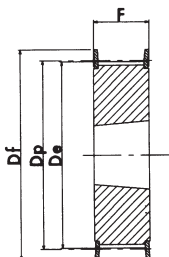

EXECUTION 5F

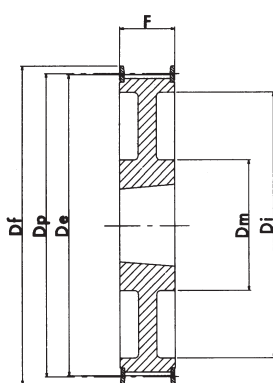

EXECUTION 6F

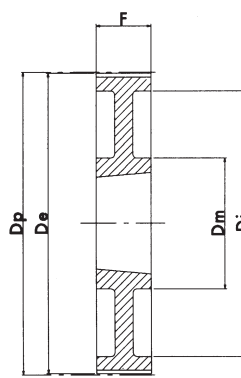

EXECUTION 7

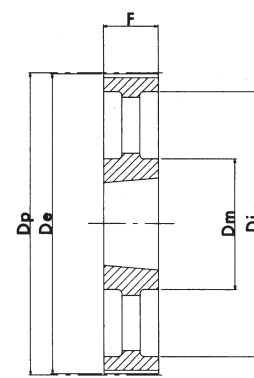

EXECUTION 8

TIPO: L 075 Passo 3/8" (9.52mm.)

CHARACTERISTICS	TYPE	EXEC.	BUSH	MAX BORE	Dp PITCH LINE	De EXTERNAL	D FLANGE	Dm HUB	Di	F	S	R	FLANGE No.	
STEEL	WITH FLANGE	TL 18 L 075	5F	1108	28	54.57	53.81	60	-	-	25.0	25.0	-	58
		TL 19 L 075	5F	1108	28	57.61	56.84	64	-	-	25.0	25.0	-	59
		TL 20 L 075	5F	1108	28	60.64	59.88	66.5	-	-	25.0	25.0	-	60
		TL 21 L 075	5F	1108	28	63.67	62.91	70	-	-	25.0	25.0	-	61
		TL 22 L 075	5F	1108	28	66.70	65.94	75	-	-	25.0	25.0	-	62
		TL 23 L 075	5F	1108	28	69.73	68.97	79	-	-	25.0	25.0	-	63
		TL 24 L 075	5F	1108	28	72.77	72.00	79	-	-	25.0	25.0	-	63
		TL 25 L 075	5F	1108	28	75.80	75.04	82.5	-	-	25.0	25.0	-	64
		TL 26 L 075	5F	1108	28	78.83	78.07	86	-	-	25.0	25.0	-	65
		TL 27 L 075	5F	1108	28	81.86	81.10	86	-	-	25.0	25.0	-	65
		TL 28 L 075	5F	1108	28	84.89	84.13	91	-	-	25.0	25.0	-	66
		TL 30 L 075	5F	1108	28	90.96	90.20	97	-	-	25.0	25.0	-	68
		TL 32 L 075	5F	1108	28	97.02	96.26	102	-	-	25.0	25.0	-	70
		TL 36 L 075	5F	1610	42	109.15	108.39	115	-	-	25.0	25.0	-	74
		TL 40 L 075	5F	1610	42	121.28	120.51	128	-	-	25.0	25.0	-	78
	TL 44 L 075	6F	1610	42	133.40	132.64	142	90	110	25.0	25.0	-	81	
	TL 48 L 075	6F	1610	42	145.53	144.77	150	92	120	25.0	25.0	-	85	
	TL 60 L 075	7	1610	42	181.91	181.15	-	92	166	25.0	25.0	-	-	
CAST-IRON	WITHOUT FLANGE	TL 72 L 075	8	1610	42	218.30	217.53	-	92	202	25.0	25.0	-	-
		TL 84 L 075	4	2012	50	254.68	253.90	-	106	236	25.0	32.0	3.5	-
		TL 96 L 075	4	2012	50	291.06	290.30	-	106	270	25.0	32.0	3.5	-
		TL 120 L 075	4	2012	50	363.83	363.07	-	106	343	25.0	32.0	3.5	-

TAPER-LOCK® PULLEYS

" PHOSPHATED "

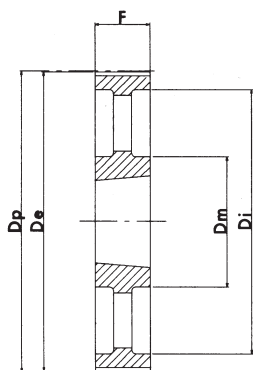

EXECUTION 8

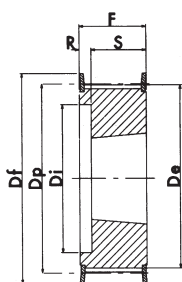

EXECUTION 9F

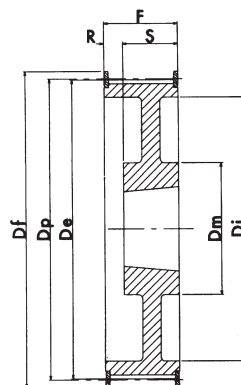

EXECUTION 10F

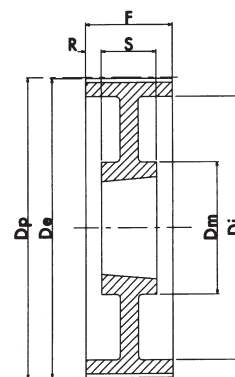

EXECUTION 11

L 100 PITCH 3/8" (9.52mm.)

CHARACTERISTICS	TYPE	EXEC.	BUSH	MAX BORE	Dp PITCH LINE	De EXTERNAL	D FLANGE	Dm HUB	Di	F	S	R	FLANGE No.	
STEEL	WITH FLANGE	TL 18 L 100	9F	1108	28	54.57	53.81	60	-	38	31.0	22.0	9.0	58
		TL 19 L 100	9F	1108	28	57.61	56.84	64	-	38	31.0	22.0	9.0	59
		TL 20 L 100	9F	1108	28	60.64	59.88	66.5	-	45	31.0	22.0	9.0	60
		TL 21 L 100	9F	1108	28	63.67	62.91	70	-	45	31.0	22.0	9.0	61
		TL 22 L 100	9F	1108	28	66.70	65.94	75	-	48	31.0	22.0	9.0	62
		TL 23 L 100	9F	1108	28	69.73	68.97	79	-	52	32.0	22.0	10.0	63
		TL 24 L 100	9F	1108	28	72.77	72.00	79	-	52	32.0	22.0	10.0	63
		TL 25 L 100	9F	1108	28	75.80	75.04	82.5	-	54	32.0	22.0	10.0	64
		TL 26 L 100	9F	1108	28	78.83	78.07	86	-	60	32.0	22.0	10.0	65
	TL 27 L 100	9F	1108	28	81.86	81.10	86	-	60	32.0	22.0	10.0	65	
	TL 28 L 100	9F	1108	28	84.89	84.13	91	-	65	32.0	22.0	10.0	66	
	TL 30 L 100	9F	1210	32	90.96	90.20	97	-	71	32.0	25.0	7.0	68	
	TL 32 L 100	9F	1210	32	97.02	96.26	102	-	75	32.0	25.0	7.0	70	
	TL 36 L 100	9F	1610	42	109.15	108.39	115	-	86	32.0	25.0	7.0	74	
	TL 40 L 100	9F	1610	42	121.28	120.51	128	-	96	32.0	25.0	7.0	78	
	TL 44 L 100	10F	1610	42	133.40	132.64	142	90	110	32.0	25.0	7.0	81	
	TL 48 L 100	10F	1610	42	145.53	144.77	150	92	120	32.0	25.0	7.0	85	
	CAST-IRON	WITHOUT FLANGE	TL 60 L 100	11	1610	42	181.91	181.15	-	92	166	32.0	25.0	3.5
TL 72 L 100			8	2012	50	218.30	217.53	-	106	202	32.0	32.0	-	-
TL 84 L 100			8	2012	50	254.68	253.90	-	106	236	32.0	32.0	-	-
TL 96 L 100			8	2012	50	291.06	290.30	-	106	270	32.0	32.0	-	-
TL 120 L 100			8	2012	50	363.83	363.07	-	106	343	32.0	32.0	-	-

TAPER-LOCK® PULLEYS "PHOSPHATED"

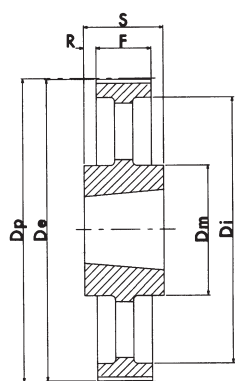

EXECUTION 4

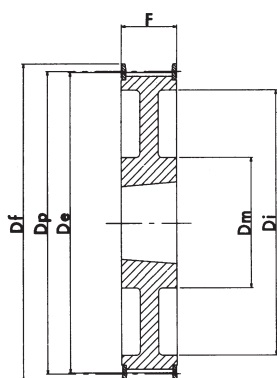

EXECUTION 6F

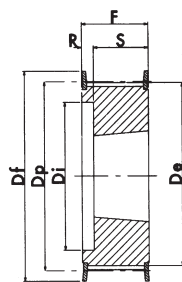

EXECUTION 9F

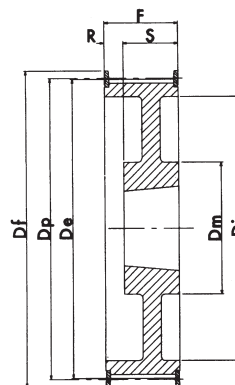

EXECUTION 10F

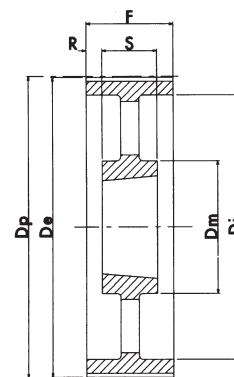

EXECUTION 12

H 100 PITCH 1/2" (12.7mm.)

CHARACTERISTICS	TYPE	EXEC.	BUSH	MAX BORE	Dp PITCH LINE	De EXTERNAL	D FLANGE	Dm HUB	Di	F	S	R	FLANGE No.	
STEEL	WITH FLANGE	TL 16 H 100	9F	1108	28	64.68	63.31	70	-	45	31.0	22.0	9.0	61
		TL 18 H 100	9F	1210	32	72.77	71.39	79	-	52	31.0	25.0	6.0	63
		TL 19 H 100	9F	1210	32	76.81	74.44	82.5	-	56	31.0	25.0	6.0	64
		TL 20 H 100	9F	1210	32	80.55	79.48	87	-	60	31.0	25.0	6.0	76
		TL 21 H 100	9F	1210	32	84.89	83.52	91	-	64	32.0	25.0	7.0	66
		TL 22 H 100	9F	1210	32	88.94	87.56	94	-	67	32.0	25.0	7.0	67
		TL 23 H 100	9F	1610	42	92.98	91.61	97	-	70	32.0	25.0	7.0	68
		TL 24 H 100	9F	1610	42	97.02	95.65	102	-	73.5	32.0	25.0	7.0	70
		TL 25 H 100	9F	1610	42	101.06	99.69	106	-	77	32.0	25.0	7.0	71
		TL 26 H 100	9F	1610	42	105.11	103.73	112	-	82	32.0	25.0	7.0	72
		TL 27 H 100	9F	1610	42	109.15	107.78	115	-	85	32.0	25.0	7.0	74
		TL 28 H 100	9F	1610	42	113.19	111.82	120	-	90.5	32.0	25.0	7.0	75
		TL 30 H 100	9F	1610	42	121.28	119.90	128	-	98	32.0	25.0	7.0	78
		TL 32 H 100	10F	1610	42	129.36	127.99	135	80	106	32.0	25.0	7.0	80
		TL 36 H 100	10F	1610	42	145.53	144.16	150	92	121	32.0	25.0	7.0	85
		TL 40 H 100	10F	1610	42	161.70	160.33	168	92	138	32.0	25.0	7.0	90
		TL 44 H 100	6F	2012	50	177.87	176.50	184	106	152	32.0	32.0	-	95
		TL 48 H 100	6F	2012	50	194.04	192.67	200	106	169	32.0	32.0	-	100
CAST-IRON	WITHOUT FLANGE	TL 60 H 100	12	2012	50	242.55	241.18	-	106	223	34.0	32.0	1.0	-
		TL 72 H 100	12	2012	50	291.06	289.69	-	106	270	34.0	32.0	1.0	-
		TL 84 H 100	12	2012	50	339.57	338.20	-	106	318	34.0	32.0	1.0	-
		TL 96 H 100	4	2517	60	388.08	386.71	-	119	366	34.0	45.0	5.5	-
		TL 120 H 100	4	2517	60	485.10	483.73	-	119	462	34.0	45.0	5.5	-

TAPER-LOCK® PULLEYS

" PHOSPHATED "

H 150 PITCH 1/2" (12.7mm.)

CHARACTERISTICS		TYPE	EXEC.	BUSH	MAX BORE	Dp PITCH LINE	De EXTERNAL	D FLANGE	Dm HUB	Di	F	S	R	FLANGE No.
STEEL	WITH FLANGE	TL 18 H 150	9F	1210	32	72.77	71.39	79	-	52	45.0	25.0	20.0	63
		TL 19 H 150	9F	1210	32	76.81	74.44	82.5	-	56	45.0	25.0	20.0	64
		TL 20 H 150	9F	1210	32	80.55	79.48	87	-	60	45.0	25.0	20.0	76
		TL 21 H 150	9F	1210	32	84.89	83.52	91	-	64	45.0	25.0	20.0	66
		TL 22 H 150	9F	1210	32	88.94	87.56	94	-	67	45.0	25.0	20.0	67
		TL 23 H 150	9F	1610	42	92.98	91.61	97	-	70	45.0	25.0	20.0	68
		TL 24 H 150	9F	1610	42	97.02	95.65	102	-	73.5	45.0	25.0	20.0	70
		TL 25 H 150	9F	1610	42	101.06	99.69	106	-	77	45.0	25.0	20.0	71
		TL 26 H 150	9F	1610	42	105.11	103.73	112	-	82	45.0	25.0	20.0	72
		TL 27 H 150	9F	1610	42	109.15	107.78	115	-	85	45.0	25.0	20.0	74
		TL 28 H 150	9F	1610	42	113.19	111.82	120	-	90.5	45.0	25.0	20.0	75
		TL 30 H 150	9F	1610	42	121.28	119.90	128	-	98	45.0	25.0	20.0	78
		TL 32 H 150	10F	1610	42	129.36	127.99	135	80	106	45.0	25.0	20.0	80
		TL 36 H 150	10F	1610	42	145.53	144.16	150	92	121	45.0	25.0	20.0	85
		TL 40 H 150	10F	1610	42	161.70	160.33	168	92	138	45.0	25.0	20.0	90
		TL 44 H 150	10F	2012	50	177.87	176.50	184	106	152	45.0	32.0	13.0	95
		TL 48 H 150	10F	2012	50	194.04	192.67	200	106	169	45.0	32.0	13.0	100
		CAST-IRON	WITHOUT FLANGE	TL 60 H 150	12	2012	50	242.55	241.18	-	106	223	46.0	32.0
TL 72 H 150	12			2012	50	291.06	289.69	-	106	270	46.0	32.0	7.0	-
TL 84 H 150	12			2012	50	339.57	338.20	-	106	318	46.0	32.0	7.0	-
TL 96 H 150	12			2517	60	388.08	386.71	-	119	366	46.0	45.0	0.5	-
TL 120 H 150	12			2517	60	485.10	483.73	-	119	462	46.0	45.0	0.5	-

H 200 PITCH 1/2" (12.7mm.)

CHARACTERISTICS		TYPE	EXEC.	BUSH	MAX BORE	Dp PITCH LINE	De EXTERNAL	D FLANGE	Dm HUB	Di	F	S	R	FLANGE No.
STEEL	WITH FLANGE	TL 18 H 200	9F	1210	32	72.77	71.39	79	-	52	58.0	25.0	33.0	63
		TL 19 H 200	9F	1210	32	76.81	74.44	82.5	-	56	58.0	25.0	33.0	64
		TL 20 H 200	9F	1610	42	80.85	79.48	87	-	62	58.0	25.0	33.0	76
		TL 21 H 200	9F	1610	42	84.89	83.52	91	-	64	58.0	25.0	33.0	66
		TL 22 H 200	9F	1610	42	88.94	87.56	94	-	67	58.0	25.0	33.0	67
		TL 23 H 200	9F	1610	42	92.98	91.61	97	-	70	58.0	25.0	33.0	68
		TL 24 H 200	9F	1610	42	97.02	95.65	102	-	73.5	58.0	25.0	33.0	70
		TL 25 H 200	9F	1610	42	101.06	99.69	106	-	77.0	58.0	25.0	33.0	71
		TL 26 H 200	9F	1610	42	105.11	103.73	112	-	82	58.0	25.0	33.0	72
		TL 27 H 200	9F	1610	42	109.15	107.78	115	-	85	58.0	25.0	33.0	74
		TL 28 H 200	9F	1610	42	113.19	111.82	120	-	90.5	58.0	25.0	33.0	75
		TL 30 H 200	9F	1610	42	121.28	119.90	128	-	98	58.0	25.0	33.0	78
		TL 32 H 200	9F	2012	50	129.36	127.99	135		106	58.0	32.0	26.0	80
		TL 36 H 200	10F	2012	50	145.53	144.16	150	102	121	58.0	32.0	26.0	85
		TL 40 H 200	10F	2012	50	161.70	160.33	168	106	138	58.0	32.0	26.0	90
		TL 44 H 200	10F	2012	50	177.87	176.50	184	106	152	58.0	32.0	26.0	95
		TL 48 H 200	10F	2517	60	194.04	192.67	200	119	168	58.0	45.0	13.0	100
		CAST-IRON	WITHOUT FLANGE	TL 60 H 200	12	2517	60	242.55	241.18	-	119	223	60.0	45.0
TL 72 H 200	12			2517	60	291.06	289.69	-	119	270	60.0	45.0	7.5	-
TL 84 H 200	12			2517	60	339.57	338.20	-	119	320	60.0	45.0	7.5	-
TL 96 H 200	12			2517	60	388.08	386.71	-	119	366	60.0	45.0	7.5	-
TL 120 H 200	12			2517	60	485.10	483.73	-	119	462	60.0	45.0	7.5	-

TAPER-LOCK® PULLEYS " PHOSPHATED "

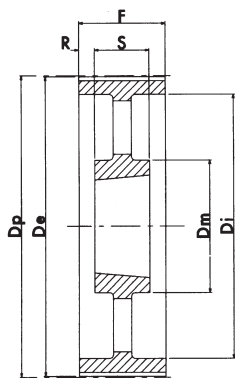

EXECUTION 12

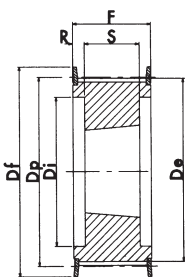

EXECUTION 13F

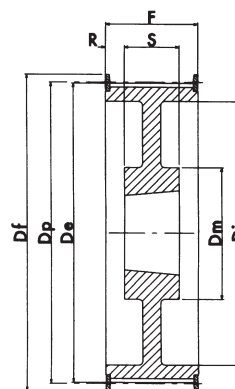

EXECUTION 14F

H 300 PITCH 1/2" (12.7mm.)

CHARACTERISTICS	TYPE	EXEC.	BUSH	MAX BORE	Dp PITCH LINE	De EXTERNAL	D FLANGE	Dm HUB	Di	F	S	R	FLANGE No.	
STEEL	WITH FLANGE	TL 20 H 300	13F	1615	42	80.85	79.48	87	-	64.5	84.0	38.0	23.0	76
		TL 21 H 300	13F	1615	42	84.89	83.52	91	-	65	84.0	38.0	23.0	66
		TL 22 H 300	13F	1615	42	88.94	87.56	94	-	67	84.0	38.0	23.0	67
		TL 23 H 300	13F	1615	42	92.98	91.61	97	-	70	84.0	38.0	23.0	68
		TL 24 H 300	13F	1615	42	97.02	95.65	102	-	73.5	84.0	38.0	23.0	70
		TL 25 H 300	13F	1615	42	101.06	99.69	106	-	77	84.0	38.0	23.0	71
		TL 26 H 300	13F	1615	42	105.11	103.73	112	-	82	84.0	38.0	23.0	72
		TL 27 H 300	13F	2012	50	109.15	107.78	115	-	85	84.0	32.0	26.0	74
		TL 28 H 300	13F	2012	50	113.19	111.82	120	-	90.5	84.0	32.0	26.0	75
		TL 30 H 300	13F	2012	50	121.28	119.90	128	-	98	84.0	32.0	26.0	78
		TL 32 H 300	13F	2517	60	129.36	127.99	135	-	106	84.0	45.0	19.5	80
		TL 36 H 300	13F	2517	60	145.53	144.16	150	-	121	84.0	45.0	19.5	85
		TL 40 H 300	13F	2517	60	161.70	160.33	168	-	138	84.0	45.0	19.5	90
		TL 44 H 300	14F	2517	60	177.87	176.50	184	119	150	86.0	45.0	20.5	95
TL 48 H 300	14F	2517	60	194.04	192.67	200	119	165	86.0	45.0	20.5	100		
CAST-IRON	WITHOUT FLANGE	TL 60 H 300	12	2517	60	242.55	241.18	-	119	223	86.0	45.0	20.5	-
		TL 72 H 300	12	2517	60	291.06	289.69	-	119	270	86.0	45.0	20.5	-
		TL 84 H 300	12	2517	60	339.57	338.20	-	119	320	86.0	45.0	20.5	-
		TL 96 H 300	12	3030	75	388.08	386.71	-	150	362	86.0	76.0	5.0	-
		TL 120 H 300	12	3030	75	485.10	483.73	-	150	460	86.0	76.0	5.0	-

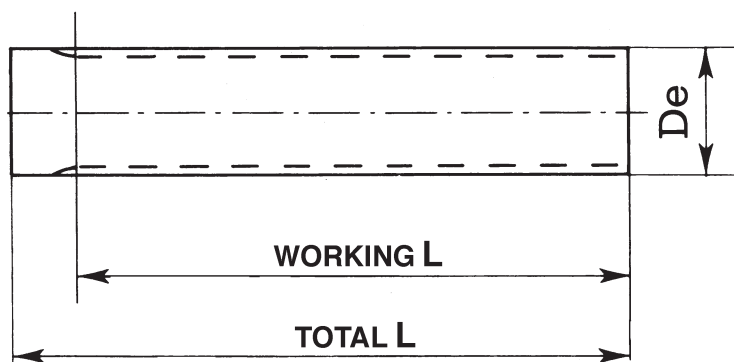

MXL 0.080" (2.032 mm.)

DESCRIPTION	No. of TEETH	De EXTERNAL	L WORKING	L TOTAL
MXL 12	12	7.26	50	75
MXL 14	14	8.56	50	75
MXL 15	15	9.19	50	75
MXL 16	16	9.83	50	75
MXL 18	18	11.12	50	75
MXL 20	20	12.42	90	120
MXL 22	22	13.72	125	140
MXL 24	24	15.01	125	140
MXL 25	25	15.67	125	140
MXL 26	26	16.31	125	140
MXL 28	28	17.60	125	140
MXL 30	30	18.90	125	140
MXL 32	32	20.19	125	140
MXL 34	34	21.49	125	140
MXL 36	36	22.78	132	140
MXL 38	38	24.08	132	140
MXL 40	40	25.37	132	140
MXL 42	42	26.67	140	140
MXL 44	44	27.94	140	140
MXL 45	45	28.60	140	140
MXL 48	48	30.53	140	140
MXL 50	50	31.83	140	140
MXL 60	60	38.30	160	160
MXL 70	70	44.78	160	160
MXL 72	72	46.05	160	160

XL 1/5" (5.08 mm.)

DESCRIPTION	No. of TEETH	De EXTERNAL	L WORKING	L TOTAL
XL 10	10	15.66	125	140
XL 11	11	17.28	125	140
XL 12	12	18.90	125	140
XL 13	13	20.51	125	140
XL 14	14	22.13	132	140
XL 15	15	23.75	132	140
XL 16	16	25.36	140	140
XL 17	17	26.98	140	140
XL 18	18	28.60	140	140
XL 19	19	30.22	140	140
XL 20	20	31.83	140	140
XL 21	21	33.45	160	160
XL 22	22	35.07	160	160
XL 23	23	36.60	160	160
XL 24	24	38.30	160	160
XL 25	25	39.93	160	160
XL 26	26	41.53	160	160
XL 27	27	43.15	160	160
XL 28	28	44.77	160	160
XL 29	29	46.39	160	160
XL 30	30	48.00	160	160
XL 32	32	51.24	160	160
XL 33	33	52.76	160	160
XL 34	34	54.47	160	160
XL 35	35	56.09	160	160
XL 36	36	57.70	160	160
XL 38	38	60.94	160	160
XL 39	39	62.56	160	160
XL 40	40	64.17	160	160
XL 41	41	65.79	160	160
XL 42	42	67.41	160	160
XL 43	43	69.02	160	160
XL 44	44	70.64	160	160
XL 48	48	77.11	160	160
XL 56	56	90.04	160	160
XL 60	60	96.51	160	160
XL 72	72	115.92	160	160

L 3/8" (9.525 mm.)

DESCRIPTION	No. of TEETH	De EXTERNAL	L WORKING	L TOTAL
L 10	10	29.56	140	140
L 11	11	32.59	140	140
L 12	12	35.62	160	160
L 13	13	38.65	160	160
L 14	14	41.68	160	160
L 15	15	44.72	160	160
L 16	16	47.75	160	160
L 17	17	50.78	160	160
L 18	18	53.81	160	160
L 19	19	56.84	160	160
L 20	20	59.88	160	160
L 21	21	62.91	160	160
L 22	22	65.94	160	160
L 23	23	68.97	160	160
L 24	24	72.00	160	160
L 27	27	81.10	160	160
L 30	30	90.20	160	160

N.B.

The MXL pitch bars are only manufactured in Aluminium suitable for hard anodising.
The XL - L bars are only manufactured in Steel and Aluminium suitable for hard anodising.

POWERGRIP® - HTD®

TOOTHED BELTS

The HTD® toothed belts are produced with the following pitches: 3mm., 5mm., 8mm., 14mm. and 20mm.

The 3mm., 5mm., 8mm. and 14mm. pitches are marketed by **CHIARAVALLI Trasmissioni S.p.A.** in a wide range of lengths and widths.

The main belt dimensions are as follows:

PITCH LINE LENGTH - PITCH - WIDTH

The product of the pitch by the number of teeth of a given belt corresponds to the belt's pitch line length.

The belt pitch is given by the distance between the axes of two adjacent teeth, in mm., measured along the belt's pitch line.

The theoretical pitch line of a HTD® belt is positioned halfway along the reinforcing inserts.

Belt characteristics

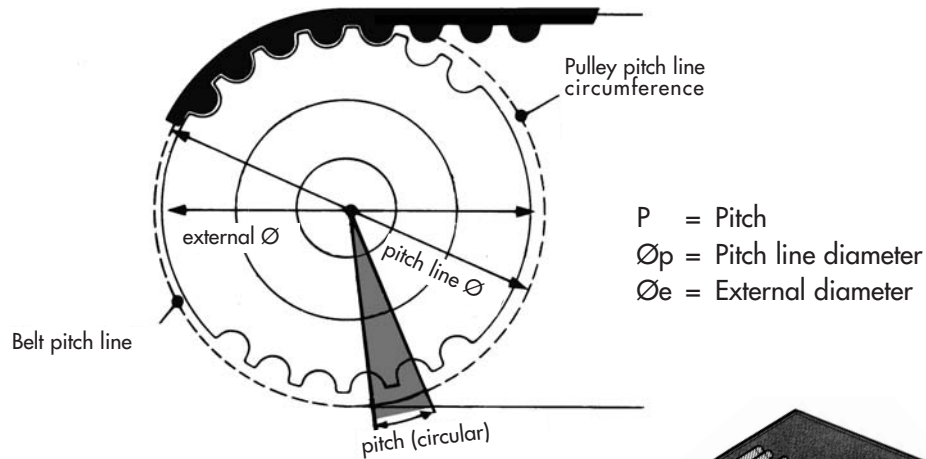

Belt identification

Pitch line extension

Pitch in mm.

Belt width

1040 - 8M - 50

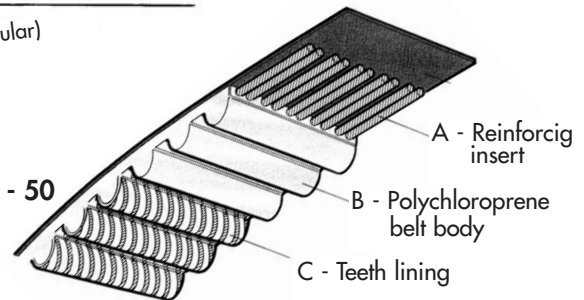

HTD® 3M

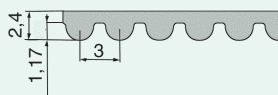

HTD® 8M

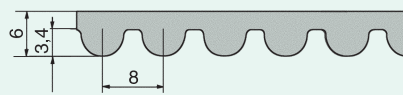

HTD® 5M

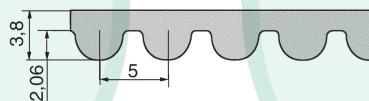

HTD® 14M

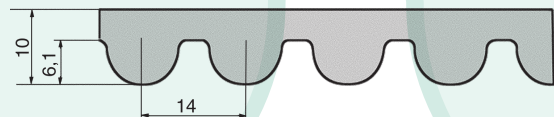

Belt tolerances along the pitch line length are limited, to achieve the correct belt tension therefore, it is necessary to be able to adjust the centres distance or tension the belt using a tensioning roller.

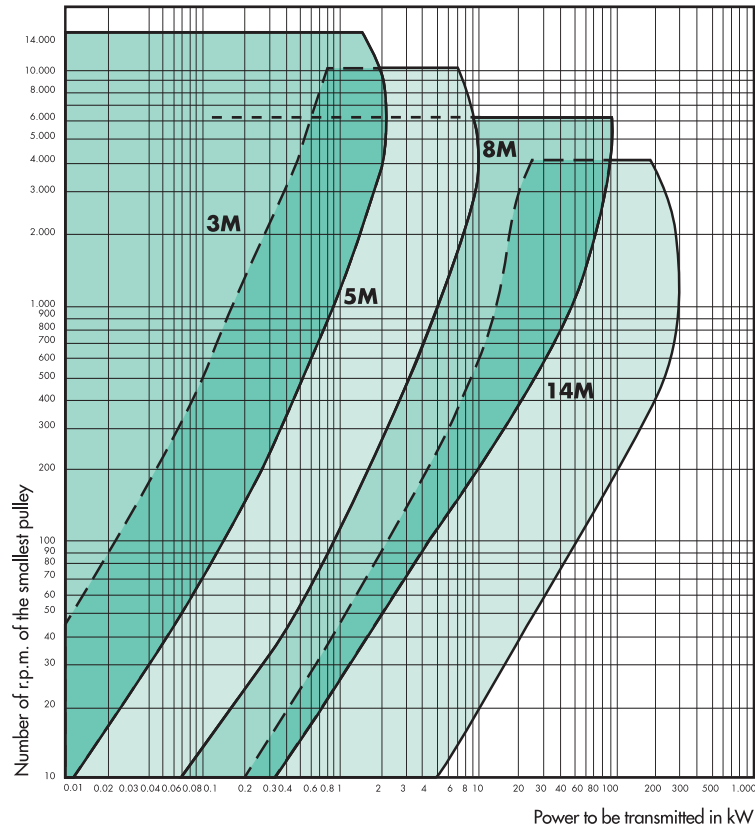

HTD® BELT WIDTHS

PITCH	HTD® 3M	HTD® 5M	HTD® 8M	HTD® 14M
BELT WIDTHS mm.	6 9 15	9 15 25	20 30 50 85	40 55 85 115 170

TOLERANCE ON CENTRES DISTANCE

BELTS PITCH LINE LENGTH	CENTRES DISTANCE TOLERANCE mm.
from 127 to 254	±0.2
from 255 to 381	±0.23
from 382 to 508	±0.25
from 509 to 762	±0.30
from 763 to 1016	±0.33
from 1017 to 1270	±0.38
from 1271 to 1524	±0.41
from 1525 to 1778	±0.43
longer than 1779	add ± 0.03 for every 254 mm. of additional length.

TOLERANCES ON HTD® BELT LENGTH

BELT WIDTH	TOLERANCE mm. FOR LENGTHS from 0 to 838.2	TOLERANCE mm. FOR LENGTHS from 838.2 to 1676.4	TOLERANCE mm. FOR LENGTHS from 1676.4 and longer
from 11.1 a 38.1	+ 0.8 - 0.8	+ 0.8 - 1.2	+ 0.8 - 1.2
from 38.2 a 50.8	+ 0.8 - 1.2	+ 1.2 - 1.2	+ 1.2 - 1.6
from 50.9 a 63.5	+ 1.2 - 1.2	+ 1.2 - 1.6	+ 1.6 - 1.6
from 63.6 a 76.2	+ 1.2 - 1.6	+ 1.6 - 1.6	+ 1.6 - 2.0
from 76.3 a 101.6	+ 1.6 - 1.6	+ 1.6 - 2.0	+ 2.0 - 2.0
from 101.7 a 177.8	+ 2.4 - 2.4	+ 1.6 - 2.0	+ 2.0 - 2.0
longer than 177.9			+ 4.8 - 6.4

" G A T E S [®] " P O W E R G R I P [®] B E L T S

HTD [®] 3M (3mm pitch)			HTD [®] 5M (5mm pitch)			HTD [®] 8M (8mm pitch)			HTD [®] 14M (14mm pitch)		
No. of TEETH	PITCH LINE LENGTH	BELT TYPE	No. of TEETH	PITCH LINE LENGTH	BELT TYPE	No. of TEETH	PITCH LINE LENGTH	BELT TYPE	No. of TEETH	PITCH LINE LENGTH	BELT TYPE
50	150	150-3M	36	180	180-5M	60	480	480-8M	69	966	966-14M
55	165	165-3M	45	225	225-5M	70	560	560-8M	85	1190	1190-14M
60	180	180-3M	51	255	255-5M	75	600	600-8M	100	1400	1400-14M
65	195	195-3M	56	280	280-5M	80	640	640-8M	115	1610	1610-14M
70	210	210-3M	60	300	300-5M	90	720	720-8M	127	1778	1778-14M
75	225	225-3M	61	305	305-5M	100	800	800-8M	135	1890	1890-14M
84	252	252-3M	65	325	325-5M	110	880	880-8M	150	2100	2100-14M
85	255	255-3M	68	340	340-5M	115	920	920-8M	165	2310	2310-14M
95	285	285-3M	70	350	350-5M	120	960	960-8M	175	2450	2450-14M
100	300	300-3M	75	375	375-5M	130	1040	1040-8M	185	2590	2590-14M
110	330	330-3M	80	400	400-5M	140	1120	1120-8M	200	2800	2800-14M
119	357	357-3M	85	425	425-5M	150	1200	1200-8M	225	3150	3150-14M
128	384	384-3M	90	450	450-5M	160	1280	1280-8M	250	3500	3500-14M
140	420	420-3M	95	475	475-5M	180	1440	1440-8M	275	3850	3850-14M
149	447	447-3M	100	500	500-5M	200	1600	1600-8M	309	4326	4326-14M
158	474	474-3M	105	525	525-5M	220	1760	1760-8M	327	4578	4578-14M
171	513	513-3M	110	550	550-5M	225	1800	1800-8M			
188	564	564-3M	112	560	560-5M	250	2000	2000-8M			
204	612	612-3M	115	575	575-5M	300	2400	2400-8M			
245	735	735-3M	120	600	600-5M	325	2600	2600-8M			
246	738	738-3M	127	635	635-5M	350	2800	2800-8M			
268	804	804-3M	134	670	670-5M						
			140	700	700-5M						
			150	750	750-5M						
			160	800	800-5M						
			172	860	860-5M						
			180	900	900-5M						
			190	950	950-5M						
			196	980	980-5M						
			207	1035	1035-5M						
			210	1050	1050-5M						
			235	1175	1175-5M						
			240	1200	1200-5M						
			270	1350	1350-5M						

POWERGRIP[®] HTD[®] 8M (8mm. pitch) DUAL BELTS

HTD[®] 8M (8mm pitch)

No. of TEETH	PITCH LINE LENGTH	BELT TYPE
60	480	480-8M DUAL
70	560	560-8M DUAL
75	600	600-8M DUAL
80	640	640-8M DUAL
90	720	720-8M DUAL
100	800	800-8M DUAL
110	880	880-8M DUAL
120	960	960-8M DUAL
130	1040	1040-8M DUAL
140	1120	1120-8M DUAL

HTD[®] 8M (8mm pitch)

No. of TEETH	PITCH LINE LENGTH	BELT TYPE
150	1200	1200-8M DUAL
160	1280	1280-8M DUAL
180	1440	1440-8M DUAL
200	1600	1600-8M DUAL
220	1760	1760-8M DUAL
225	1800	1800-8M DUAL
250	2000	2000-8M DUAL
300	2400	2400-8M DUAL
325	2600	2600-8M DUAL
350	2800	2800-8M DUAL

CHIARAVALLI Trasmissioni S.p.A. manufactures the HTD® pulleys in the following pitches: 3mm., 5mm., 8mm. and 14mm. and in the following versions:

- a) HTD® Pilot Bore pulleys
- b) HTD® with Taper-Lock taper bush

Belt identification:

34 8M 50 { 34 No. of teeth
8M pitch in mm.
50 belt width

TL 30 14M 55 { TL TAPER LOCK
30 No. of teeth
14M pitch in mm.
55 belt width

PULLEY BALANCING VALUES

The HTD® pulleys manufactured by our company are not balanced. Balancing is performed at cost, only on request.

We are able to balance pulleys up to a maximum diameter of 560 mm. and issue the relative certificate.

PULLEY DIAMETERS	SURFACE WIDTH	MAXIMUM UNBALANCE IN GRAMS
from 199 - 301	60	6
from 302 - 599	60	10
from 199 - 301	from 60 - 99	10
from 302 - 599		15
from 600 - 999		20
greater than 1000		30

PULLEY DIAMETER	SURFACE WIDTH	MAXIMUM UNBALANCE IN GRAMS
from 199 - 301	da 100 - 199	20
from 302 - 599		30
from 600 - 999		40
greater than 1000		60

CONSTRUCTION TOLERANCE VALUES

De pulley	Tolerance in mm.	
from Ø 0 to Ø 30	- 0	+ 0.05
from Ø 31 to Ø 50	- 0	+ 0.08
from Ø 51 to Ø 100	- 0	+ 0.10
from Ø 101 to Ø 179	- 0	+ 0.13
from Ø 180 to Ø 300	- 0	+ 0.15
from Ø 301 to Ø 500	- 0	+ 0.18
from Ø greater than Ø 51	- 0	+ 0.20

ECCENTRICITY

The bore and outer diameter must be concentric in compliance with the tolerance values indicated below

external Ø mm.	Total eccentricity (mm)
up to 199	Total measurement of the comparison 0.10
greater than 200	0.0005 per mm. diameter. This value cannot exceed the tolerance for the external Ø.

HTD[®] PILOT BORE " PHOSPHATED " PULLEYS

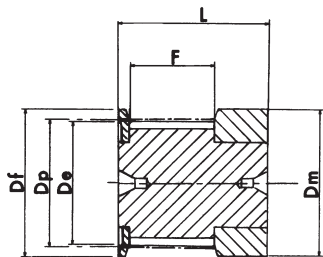

EXECUTION 0F

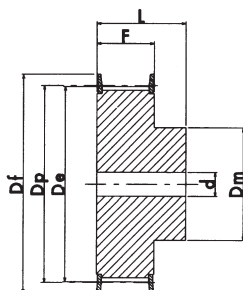

EXECUTION 1F

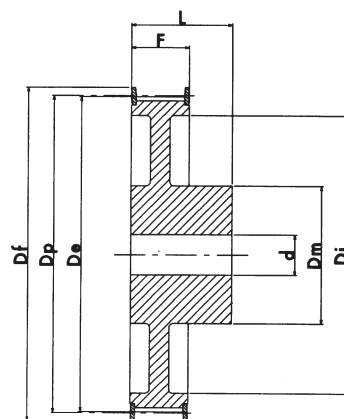

EXECUTION 2F

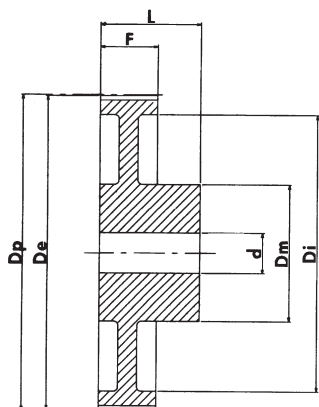

EXECUTION 3

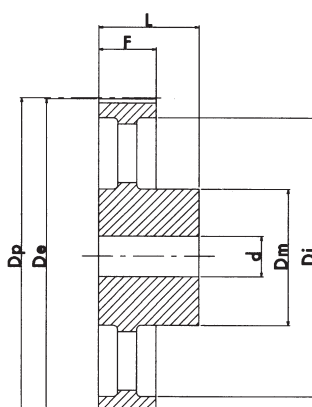

EXECUTION 4

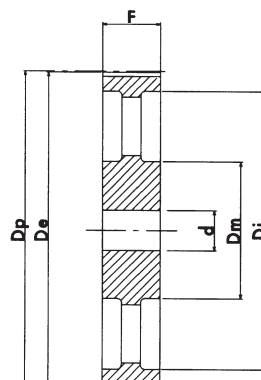

EXECUTION 5

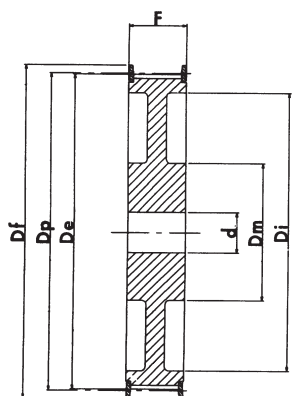

EXECUTION 6F

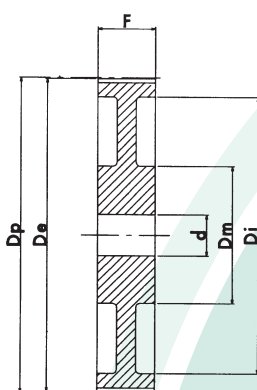

EXECUTION 7

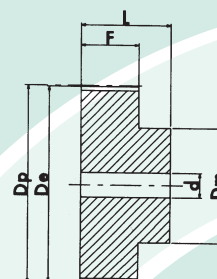

EXECUTION 8

HTD[®] PILOT BORE " PHOSPHATED " PULLEYS

HTD[®] 3M 09

CHARACTERISTICS	TYPE	No. of TEETH	EXEC.	Dp PITCH LINE	De EXTERNAL	Df FLANGE	Dm HUB	F	L	d bore Ø	FLANGE No.	
ALUMINIUM	WITH FLANGE	10-3M-09	10	OF	9.55	8.79	13.0	13.0	10.2	17.5	-	501
		12-3M-09	12	OF	11.46	10.70	15.0	15.0	10.2	17.5	-	502
		14-3M-09	14	OF	13.37	12.61	16.0	16.0	10.2	17.5	-	503
		15-3M-09	15	OF	14.32	13.56	17.5	17.5	10.2	17.5	-	516
		16-3M-09	16	1F	15.28	14.52	17.5	10.0	12.8	20.6	4.0	504
		18-3M-09	18	1F	17.19	16.43	20.0	11.0	12.8	20.6	6.0	505
		20-3M-09	20	1F	19.10	18.34	23.0	13.0	12.8	20.6	6.0	517
		21-3M-09	21	1F	20.05	19.29	25.0	14.0	12.8	20.6	6.0	518
		22-3M-09	22	1F	21.01	20.25	25.0	14.0	12.8	20.6	6.0	518
		24-3M-09	24	1F	22.92	22.16	25.0	14.0	12.8	20.6	6.0	518
		26-3M-09	26	1F	24.83	24.07	28.0	16.0	12.8	20.6	6.0	508
		28-3M-09	28	1F	26.74	25.98	32.0	18.0	12.8	20.6	6.0	509
		30-3M-09	30	1F	28.65	27.89	32.0	20.0	12.8	20.6	6.0	509
		32-3M-09	32	1F	30.56	29.80	36.0	22.0	12.8	20.6	6.0	510
	36-3M-09	36	1F	34.38	33.62	39.0	26.0	13.4	22.2	6.0	519	
	40-3M-09	40	1F	38.20	37.44	42.0	28.0	13.4	22.2	6.0	513	
	44-3M-09	44	1F	42.02	41.26	48.0	33.0	13.4	22.2	6.0	520	
	WITHOUT FLANGE	48-3M-09	48	8	45.84	45.08	-	33.0	13.4	22.2	8.0	-
		60-3M-09	60	8	57.30	56.54	-	33.0	13.4	22.2	8.0	-
		72-3M-09	72	8	68.75	67.99	-	33.0	13.4	22.2	8.0	-

HTD[®] 3M 15

CHARACTERISTICS	TYPE	No. of TEETH	EXEC.	Dp PITCH LINE	De EXTERNAL	Df FLANGE	Dm HUB	F	L	d bore Ø	FLANGE No.	
ALUMINIUM	WITH FLANGE	10-3M-15	10	OF	9.55	8.79	13.0	13.0	17.0	26.0	-	501
		12-3M-15	12	OF	11.46	10.70	15.0	15.0	17.0	26.0	-	502
		14-3M-15	14	OF	13.37	12.61	16.0	16.0	17.0	26.0	-	503
		15-3M-15	15	OF	14.32	13.56	17.5	17.5	17.0	26.0	-	516
		16-3M-15	16	1F	15.28	14.52	17.5	10.0	19.5	26.0	4.0	504
		18-3M-15	18	1F	17.19	16.43	20.0	11.0	19.5	26.0	6.0	505
		20-3M-15	20	1F	19.10	18.34	23.0	13.0	19.5	26.0	6.0	517
		21-3M-15	21	1F	20.05	19.29	25.0	14.0	19.5	26.0	6.0	518
		22-3M-15	22	1F	21.01	20.25	25.0	14.0	19.5	26.0	6.0	518
		24-3M-15	24	1F	22.92	22.16	25.0	14.0	19.5	26.0	6.0	518
		26-3M-15	26	1F	24.83	24.07	28.0	16.0	19.5	26.0	6.0	508
		28-3M-15	28	1F	26.74	25.98	32.0	18.0	19.5	26.0	6.0	509
		30-3M-15	30	1F	28.65	27.89	32.0	20.0	19.5	26.0	6.0	509
		32-3M-15	32	1F	30.56	29.80	36.0	22.0	19.5	26.0	6.0	510
	36-3M-15	36	1F	34.38	33.62	39.0	26.0	20.0	30.0	6.0	519	
	40-3M-15	40	1F	38.20	37.44	42.0	28.0	20.0	30.0	6.0	513	
	44-3M-15	44	1F	42.02	41.26	48.0	33.0	20.0	30.0	6.0	520	
	WITHOUT FLANGE	48-3M-15	48	8	45.84	45.08	-	33.0	20.0	30.0	8.0	-
		60-3M-15	60	8	57.30	56.54	-	33.0	20.0	30.0	8.0	-
		72-3M-15	72	8	68.75	67.99	-	33.0	20.0	30.0	8.0	-

HTD[®] PILOT BORE " PHOSPHATED " PULLEYS

HTD[®] 5M 09

CHARACTERISTICS	TYPE	No. of TEETH	EXEC.	Dp PITCH LINE	De EXTERNAL	Df FLANGE	Dm HUB	Di	F	L	d bore Ø	FLANGE No.			
STEEL	WITH FLANGE	12-5M-09	12	1F	19.10	17.96	23.0	13.0	-	14.5	20.0	4.0	14		
		14-5M-09	14	1F	22.28	21.14	25.0	13.0	-	14.5	20.0	6.0	2		
		15-5M-09	15	1F	23.87	22.73	28.0	16.0	-	14.5	20.0	6.0	4		
		16-5M-09	16	1F	25.46	24.32	28.0	16.5	-	14.5	20.0	6.0	4		
		18-5M-09	18	1F	28.65	27.51	32.0	20.0	-	14.5	20.0	6.0	6		
		20-5M-09	20	1F	31.83	30.69	36.0	23.0	-	14.5	22.5	6.0	8		
		21-5M-09	21	1F	33.42	32.28	38.0	24.0	-	14.5	22.5	6.0	9		
		22-5M-09	22	1F	35.01	33.87	39.0	25.5	-	14.5	22.5	6.0	15		
		24-5M-09	24	1F	38.20	37.06	42.0	27.0	-	14.5	22.5	6.0	13		
		26-5M-09	26	1F	41.38	40.24	44.0	30.0	-	14.5	22.5	6.0	12		
		28-5M-09	28	1F	44.56	43.42	48.0	30.5	-	14.5	22.5	6.0	11		
		30-5M-09	30	1F	47.75	46.60	51.0	35.0	-	14.5	22.5	6.0	16		
		32-5M-09	32	1F	50.93	49.79	54.0	38.0	-	14.5	22.5	8.0	18		
		36-5M-09	36	1F	57.30	56.16	60.0	38.0	-	14.5	22.5	8.0	21		
		40-5M-09	40	1F	63.66	62.52	71.0	38.0	-	14.5	22.5	8.0	25		
		ALUMINIUM	WITHOUT FLANGE	44-5M-09	44	3	70.03	68.89	-	38.0	54	14.5	25.5	8.0	-
				48-5M-09	48	3	76.39	75.25	-	45.0	61	14.5	25.5	8.0	-
				60-5M-09	60	3	95.49	94.35	-	45.0	80	14.5	25.5	8.0	-
				72-5M-09	72	3	114.59	113.45	-	45.0	100	14.5	25.5	8.0	-

HTD[®] 5M 15

CHARACTERISTICS	TYPE	No. of TEETH	EXEC.	Dp PITCH LINE	De EXTERNAL	Df FLANGE	Dm HUB	Di	F	L	d bore Ø	FLANGE No.			
STEEL	WITH FLANGE	12-5M-15	12	1F	19.10	17.96	23.0	13.0	-	20.5	26.0	-	14		
		14-5M-15	14	1F	22.28	21.14	25.0	13.0	-	20.5	26.0	6.0	2		
		15-5M-15	15	1F	23.87	22.73	28.0	16.0	-	20.5	26.0	6.0	4		
		16-5M-15	16	1F	25.46	24.32	28.0	16.5	-	20.5	26.0	6.0	4		
		18-5M-15	18	1F	28.65	27.51	32.0	20.0	-	20.5	26.0	6.0	6		
		20-5M-15	20	1F	31.83	30.69	36.0	23.0	-	20.5	26.0	6.0	8		
		21-5M-15	21	1F	33.42	32.28	38.0	24.0	-	20.5	26.0	6.0	9		
		22-5M-15	22	1F	35.01	33.87	39.0	25.5	-	20.5	26.0	6.0	15		
		24-5M-15	24	1F	38.20	37.06	42.0	27.0	-	20.5	28.0	6.0	13		
		26-5M-15	26	1F	41.38	40.24	44.0	30.0	-	20.5	28.0	6.0	12		
		28-5M-15	28	1F	44.56	43.42	48.0	30.5	-	20.5	28.0	6.0	11		
		30-5M-15	30	1F	47.75	46.60	51.0	35.0	-	20.5	28.0	6.0	16		
		32-5M-15	32	1F	50.93	49.79	54.0	38.0	-	20.5	28.0	8.0	18		
		36-5M-15	36	1F	57.30	56.16	60.0	38.0	-	20.5	28.0	8.0	21		
		40-5M-15	40	1F	63.66	62.52	71.0	38.0	-	20.5	28.0	8.0	25		
		ALUMINIUM	WITHOUT FLANGE	44-5M-15	44	3	70.03	68.89	-	38.0	54	20.5	30.0	8.0	-
				48-5M-15	48	3	76.39	75.25	-	38.0	61	20.5	30.0	8.0	-
				60-5M-15	60	3	95.49	94.35	-	50.0	80	20.5	30.0	8.0	-
				72-5M-15	72	3	114.59	113.45	-	50.0	100	20.5	30.0	8.0	-

N.B. Aluminium pulleys are not phosphated.

PULEGGE CON FORO INIZIALE PER CINGHIE DENTATE POWERGRIP® HTD® "FOSFATATE"

HTD® 5M 25

CHARACTERISTICS		TYPE	No. of TEETH	EXEC.	Dp PITCH LINE	De EXTERNAL	Df FLANGE	Dm HUB	Di	F	L	d bore Ø	FLANGE No.
STEEL	WITH FLANGE	12-5M-25	12	1F	19.10	17.96	23.0	13.0	-	30.5	36	-	14
		14-5M-25	14	1F	22.28	21.14	25.0	13.0	-	30.5	36	6.0	2
		15-5M-25	15	1F	23.87	22.73	28.0	16.0	-	30.5	36	6.0	4
		16-5M-25	16	1F	25.46	24.32	28.0	16.5	-	30.5	36	6.0	4
		18-5M-25	18	1F	28.65	27.51	32.0	20.0	-	30.5	36	6.0	6
		20-5M-25	20	1F	31.83	30.69	36.0	23.0	-	30.5	36	6.0	8
		21-5M-25	21	1F	33.42	32.28	38.0	24.0	-	30.5	38	6.0	9
		22-5M-25	22	1F	35.01	33.87	39.0	25.5	-	30.5	38	6.0	15
		24-5M-25	24	1F	38.20	37.06	42.0	27.0	-	30.5	38	6.0	13
		26-5M-25	26	1F	41.38	40.24	44.0	30.0	-	30.5	38	6.0	12
		28-5M-25	28	1F	44.56	43.42	48.0	30.5	-	30.5	38	6.0	11
		30-5M-25	30	1F	47.75	46.60	51.0	35.0	-	30.5	38	6.0	16
		32-5M-25	32	1F	50.93	49.79	54.0	38.0	-	30.5	38	8.0	18
		36-5M-25	36	1F	57.30	56.16	60.0	38.0	-	30.5	38	8.0	21
		40-5M-25	40	1F	63.66	62.52	71.0	38.0	-	30.5	38	8.0	25
		ALUMINIUM	WITHOUT FLANGE	44-5M-25	44	8	70.03	68.89	-	38.0	-	30.5	40
48-5M-25	48			3	76.39	75.25	-	38.0	61	30.5	40	8.0	-
60-5M-25	60			3	95.49	94.35	-	50.0	80	30.5	40	8.0	-
72-5M-25	72			3	114.59	113.45	-	50.0	100	30.5	40	8.0	-

HTD® 8M 20

CHARACTERISTICS		TYPE	No. of TEETH	EXEC.	Dp PITCH LINE	De EXTERNAL	Df FLANGE	Dm HUB	Di	F	L	d bore Ø	FLANGE No.
STEEL	WITH FLANGE	22-8M-20	22	1F	56.02	54.65	60	43	-	28	38	12	53
		24-8M-20	24	1F	61.12	59.75	66	45	-	28	38	12	69
		26-8M-20	26	1F	66.21	64.85	70	48	-	28	38	12	61
		28-8M-20	28	1F	71.30	70.08	75	50	-	28	38	15	79
		30-8M-20	30	1F	76.39	75.13	83	55	-	28	38	15	73
		32-8M-20	32	1F	81.49	80.16	87	60	-	28	38	15	76
		34-8M-20	34	1F	86.58	85.22	91	66	-	28	38	15	66
		36-8M-20	36	1F	91.67	90.30	97	70	-	28	38	15	68
		38-8M-20	38	1F	96.77	95.39	102	75	-	28	38	15	70
		40-8M-20	40	1F	101.86	100.49	106	75	-	28	38	15	77
		44-8M-20	44	1F	112.05	110.67	120	75	-	28	38	15	75
		48-8M-20	48	1F	122.23	120.86	128	75	-	28	38	15	78
		56-8M-20	56	2F	142.60	141.23	150	80	116	28	38	15	85
		64-8M-20	64	2F	162.97	161.60	168	80	137	28	38	15	90
		72-8M-20	72	2F	183.35	181.97	192	80	158	28	38	15	97
		ALUMINIUM	WITHOUT FLANGE	80-8M-20	80	3	203.72	202.35	-	90	180	28	38
90-8M-20	90			3	229.18	227.81	-	90	204	28	38	15	-
*112-8M-20	112			4	285.21	283.83	-	90	254	28	38	18	-
*144-8M-20	144			4	366.69	365.32	-	90	336	28	38	20	-
*168-8M-20	168			4	427.81	426.44	-	100	400	28	38	20	-
*192-8M-20	192			4	488.92	487.55	-	100	460	28	38	20	-

* Toothings marked with an asterisk are produced on request

HTD[®] PILOT BORE " PHOSPHATED " PULLEYS

HTD[®] 8M 30

CHARACTERISTICS		TYPE	No. of TEETH	EXEC.	Dp PITCH LINE	De EXTERNAL	Df FLANGE	Dm HUB	Di	F	L	d bore Ø	FLANGE No.		
STEEL	WITH FLANGE	22-8M-30	22	1F	56.02	54.65	60	43	-	38	48	12	53		
		24-8M-30	24	1F	61.12	59.75	66	45	-	38	48	12	69		
		26-8M-30	26	1F	66.21	64.85	70	48	-	38	48	12	61		
		28-8M-30	28	1F	71.30	70.08	75	50	-	38	48	15	79		
		30-8M-30	30	1F	76.39	75.13	83	55	-	38	48	15	73		
		32-8M-30	32	1F	81.49	80.16	87	60	-	38	48	15	76		
		34-8M-30	34	1F	86.58	85.22	91	66	-	38	48	15	66		
		36-8M-30	36	1F	91.67	90.30	97	70	-	38	48	15	68		
		38-8M-30	38	1F	96.77	95.39	102	75	-	38	48	15	70		
		40-8M-30	40	1F	101.86	100.49	106	75	-	38	48	15	77		
		44-8M-30	44	1F	112.05	110.67	120	75	-	38	48	15	75		
		48-8M-30	48	1F	122.23	120.86	128	75	-	38	48	15	78		
		56-8M-30	56	2F	142.60	141.23	150	90	116	38	48	15	85		
		64-8M-30	64	2F	162.97	161.60	168	90	137	38	48	15	90		
		72-8M-30	72	2F	183.35	181.97	192	95	158	38	48	15	97		
		CAST IRON	WITHOUT FLANGE	80-8M-30	80	3	203.72	202.35	-	100	180	38	48	15	-
				90-8M-30	90	3	229.18	227.81	-	100	204	38	48	15	-
112-8M-30	112			4	285.21	283.83	-	100	254	38	48	18	-		
144-8M-30	144			4	366.69	365.32	-	100	336	38	48	20	-		
168-8M-30	168			4	427.81	426.44	-	100	400	38	48	20	-		
192-8M-30	192			4	488.92	487.55	-	100	460	38	48	20	-		

HTD[®] 8M 50

CHARACTERISTICS		TYPE	No. of TEETH	EXEC.	Dp PITCH LINE	De EXTERNAL	Df FLANGE	Dm HUB	Di	F	L	d bore Ø	FLANGE No.		
STEEL	WITH FLANGE	22-8M-50	22	1F	56.02	54.65	60	43	-	60	70	-	53		
		24-8M-50	24	1F	61.12	59.75	66	45	-	60	70	-	69		
		26-8M-50	26	1F	66.21	64.85	70	48	-	60	70	-	61		
		28-8M-50	28	1F	71.30	70.08	75	50	-	60	70	-	79		
		30-8M-50	30	1F	76.39	75.13	83	55	-	60	70	-	73		
		32-8M-50	32	1F	81.49	80.16	87	60	-	60	70	-	76		
		34-8M-50	34	1F	86.58	85.22	91	66	-	60	70	-	66		
		36-8M-50	36	1F	91.67	90.30	97	70	-	60	70	-	68		
		38-8M-50	38	1F	96.77	95.39	102	75	-	60	70	-	70		
		40-8M-50	40	1F	101.86	100.49	106	75	-	60	70	-	77		
		44-8M-50	44	1F	112.05	110.67	120	75	-	60	70	-	75		
		48-8M-50	48	1F	122.23	120.86	128	80	-	60	70	-	78		
		56-8M-50	56	6F	142.60	141.23	150	90	116	60	60	18	85		
		64-8M-50	64	6F	162.97	161.60	168	100	137	60	60	18	90		
		72-8M-50	72	6F	183.35	181.97	192	100	158	60	60	18	97		
		CAST IRON	WITHOUT FLANGE	80-8M-50	80	7	203.72	202.35	-	110	180	60	60	18	-
				90-8M-50	90	7	229.18	227.81	-	110	204	60	60	18	-
112-8M-50	112			5	285.21	283.83	-	110	254	60	60	18	-		
144-8M-50	144			5	366.69	365.32	-	110	336	60	60	20	-		
168-8M-50	168			5	427.81	426.44	-	120	400	60	60	20	-		
192-8M-50	192			5	488.92	487.55	-	130	460	60	60	20	-		

HTD® PILOT BORE " PHOSPHATED " PULLEYS

HTD® 8M 85

CHARACTERISTICS	TYPE	No. of TEETH	EXEC.	Dp PITCH LINE	De EXTERNAL	Df FLANGE	Dm HUB	Di	F	L	d bore Ø	FLANGE No.		
STEEL	WITH FLANGE	22-8M-85	22	1F	56.02	54.65	60	43	-	95	105	-	53	
		24-8M-85	24	1F	61.12	59.75	66	45	-	95	105	-	69	
		26-8M-85	26	1F	66.21	64.85	70	48	-	95	105	-	61	
		28-8M-85	28	1F	71.30	70.08	75	50	-	95	105	-	79	
		30-8M-85	30	1F	76.39	75.13	83	55	-	95	105	-	73	
		32-8M-85	32	1F	81.49	80.16	87	60	-	95	105	-	76	
		34-8M-85	34	1F	86.58	85.22	91	66	-	95	105	-	66	
		36-8M-85	36	1F	91.67	90.30	97	70	-	95	105	-	68	
		38-8M-85	38	1F	96.77	95.39	102	75	-	95	105	-	70	
	40-8M-85	40	1F	101.86	100.49	106	75	-	95	105	-	77		
	44-8M-85	44	1F	112.05	110.67	120	75	-	95	105	-	75		
	48-8M-85	48	1F	122.23	120.86	128	80	-	95	105	-	78		
	56-8M-85	56	1F	142.60	141.23	150	90	-	95	105	20	85		
	64-8M-85	64	6F	162.97	161.60	168	100	137	95	95	20	90		
	72-8M-85	72	6F	183.35	181.97	192	100	158	95	95	20	97		
	CAST IRON	WITHOUT FLANGE	80-8M-85	80	5	203.72	202.35		110	180	95	95	20	-
			90-8M-85	90	5	229.18	227.81		110	204	95	95	20	-
			112-8M-85	112	5	285.21	283.83		110	254	95	95	24	-
144-8M-85			144	5	366.69	365.32		110	336	95	95	24	-	
*168-8M-85			168	5	427.81	426.44		120	400	95	95	24	-	
*192-8M-85			192	5	488.92	487.55		130	460	95	95	24	-	

HTD® 14M 40

CHARACTERISTICS	TYPE	No. of TEETH	EXEC.	Dp PITCH LINE	De EXTERNAL	Df FLANGE	Dm HUB	Di	F	L	d bore Ø	FLANGE No.	
STEEL	WITH FLANGE	28-14M-40	28	1F	124.78	122.12	128	100	-	54	69	24	153
		*29-14M-40	29	1F	129.23	126.57	138	100	-	54	69	24	154
		30-14M-40	30	1F	133.69	130.99	138	100	-	54	69	24	154
		32-14M-40	32	1F	142.60	139.88	154	100	-	54	69	24	160
		34-14M-40	34	1F	151.52	148.79	160	100	-	54	69	24	166
		36-14M-40	36	1F	160.43	157.68	168	100	-	54	69	24	168
		38-14M-40	38	1F	169.34	166.60	183	120	-	54	69	24	172
		40-14M-40	40	1F	178.25	175.49	188	120	-	54	69	24	162
		44-14M-40	44	1F	196.08	193.28	211	120	-	54	69	24	175
		48-14M-40	48	2F	213.90	211.11	226	135	170	54	69	24	180
		56-14M-40	56	2F	249.55	246.76	256	135	207	54	69	28	182
		64-14M-40	64	2F	285.21	282.41	296	135	240	54	69	28	184
CAST IRON	WITHOUT FLANGE	72-14M-40	72	4	320.86	318.06	-	135	278	54	69	28	-
		80-14M-40	80	4	356.51	353.71	-	135	314	54	69	28	-
		90-14M-40	90	4	401.07	398.28	-	135	358	54	69	28	-
		112-14M-40	112	4	499.11	496.32	-	135	456	54	69	28	-
		*144-14M-40	144	4	641.71	638.92	-	135	600	54	69	28	-
		*168-14M-40	168	4	748.66	745.87	-	135	706	54	69	28	-
		*192-14M-40	192	4	855.62	852.82	-	135	813	54	69	28	-
		*216-14M-40	216	4	962.57	959.76	-	150	920	54	69	28	-

* Toothings marked with an asterisk are produced on request

HTD® PILOT BORE " PHOSPHATED " PULLEYS

HTD® 14M 55

CHARACTERISTICS	TYPE	No. of TEETH	EXEC.	Dp PITCH LINE	De EXTERNAL	Df FLANGE	Dm HUB	Di	F	L	d bore Ø	FLANGE No.		
STEEL	WITH FLANGE	28-14M-55	28	1F	124.78	122.12	128	100	-	70	85	24	153	
		*29-14M-55	29	1F	129.23	126.57	138	100	-	70	85	24	154	
		30-14M-55	30	1F	133.69	130.99	138	100	-	70	85	24	154	
		32-14M-55	32	1F	142.60	139.88	154	100	-	70	85	24	160	
		34-14M-55	34	1F	151.52	148.79	160	100	-	70	85	24	166	
		36-14M-55	36	1F	160.43	157.68	168	100	-	70	85	24	168	
		38-14M-55	38	1F	169.34	166.6	183	120	-	70	85	24	172	
		40-14M-55	40	1F	178.25	175.49	188	120	-	70	85	24	162	
	44-14M-55	44	1F	196.08	193.28	211	120	-	70	85	24	175		
	48-14M-55	48	6F	213.90	211.11	226	135	170	70	70	24	180		
	56-14M-55	56	6F	249.55	246.76	256	135	207	70	70	28	182		
	64-14M-55	64	6F	285.21	282.41	296	135	240	70	70	28	184		
	CAST IRON	WITHOUT FLANGE	72-14M-55	72	5	320.86	318.06	-	135	278	70	70	28	-
			80-14M-55	80	5	356.51	353.71	-	135	314	70	70	28	-
			90-14M-55	90	5	401.07	398.28	-	135	358	70	70	28	-
			112-14M-55	112	5	499.11	496.32	-	135	456	70	70	28	-
144-14M-55			144	5	641.71	638.92	-	135	600	70	70	28	-	
168-14M-55			168	5	748.66	745.87	-	135	706	70	70	28	-	
192-14M-55			192	5	855.62	852.82	-	135	813	70	70	28	-	
*216-14M-55			216	5	962.57	959.76	-	150	920	70	70	28	-	

HTD® 14M 85

CHARACTERISTICS	TYPE	No. of TEETH	EXEC.	Dp PITCH LINE	De EXTERNAL	Df FLANGE	Dm HUB	Di	F	L	d bore Ø	FLANGE No.		
STEEL	WITH FLANGE	28-14M-85	28	1F	124.78	122.12	128	100	-	102	117	-	153	
		*29-14M-85	29	1F	129.23	126.57	138	100	-	102	117	-	154	
		30-14M-85	30	1F	133.69	130.99	138	100	-	102	117	-	154	
		32-14M-85	32	1F	142.60	139.88	154	100	-	102	117	-	160	
		34-14M-85	34	1F	151.52	148.79	160	100	-	102	117	-	166	
		36-14M-85	36	1F	160.43	157.68	168	100	-	102	117	-	168	
		38-14M-85	38	1F	169.34	166.60	183	120	-	102	117	-	172	
		40-14M-85	40	1F	178.25	175.49	188	135	-	102	117	-	162	
	44-14M-85	44	1F	196.08	193.28	211	135	-	102	117	-	175		
	48-14M-85	48	1F	213.90	211.11	226	150	-	102	117	-	180		
	56-14M-85	56	6F	249.55	246.76	256	150	207	102	102	32	182		
	64-14M-85	64	6F	285.21	282.41	296	150	240	102	102	32	184		
	CAST IRON	WITHOUT FLANGE	72-14M-85	72	5	320.86	318.06	-	150	278	102	102	32	-
			80-14M-85	80	5	356.51	353.71	-	150	314	102	102	32	-
			90-14M-85	90	5	401.07	398.28	-	150	358	102	102	32	-
			112-14M-85	112	5	499.11	496.32	-	150	456	102	102	32	-
144-14M-85			144	5	641.71	638.92	-	150	600	102	102	32	-	
168-14M-85			168	5	748.66	745.87	-	150	706	102	102	32	-	
192-14M-85			192	5	855.62	852.82	-	165	813	102	102	32	-	
*216-14M-85			216	5	962.57	959.76	-	165	920	102	102	32	-	

* Toothings marked with an asterisk are produced on request

HTD[®] PILOT BORE " PHOSPHATED " PULLEYS

HTD[®] 14M 115

CHARACTERISTICS	TYPE	No. of TEETH	EXEC.	Dp PITCH LINE	De EXTERNAL	Df FLANGE	Dm HUB	Di	F	L	d bore Ø	FLANGE No.			
STEEL	WITH FLANGE	28-14M-115	28	1F	124.78	122.12	128	100	-	133	148	-	153		
		*29-14M-115	29	1F	129.23	126.57	138	100	-	133	148	-	154		
		30-14M-115	30	1F	133.69	130.99	138	100	-	133	148	-	154		
		32-14M-115	32	1F	142.60	139.88	154	100	-	133	148	-	160		
		34-14M-115	34	1F	151.52	148.79	160	100	-	133	148	-	166		
		36-14M-115	36	1F	160.43	157.68	168	120	-	133	148	-	168		
		38-14M-115	38	1F	169.34	166.60	183	120	-	133	148	-	172		
		40-14M-115	40	1F	178.25	175.49	188	135	-	133	148	-	162		
		44-14M-115	44	1F	196.08	193.28	211	140	-	133	148	-	175		
		48-14M-115	48	1F	213.90	211.11	226	150	-	133	148	-	180		
		56-14M-115	56	1F	249.55	246.76	256	150	-	133	148	-	182		
		CAST IRON	WITHOUT FLANGE	64-14M-115	64	6F	285.21	282.41	296	150	240	133	133	32	184
				72-14M-115	72	5	320.86	318.06	-	150	278	133	133	32	-
				80-14M-115	80	5	356.51	353.71	-	150	314	133	133	32	-
				90-14M-115	90	5	401.07	398.28	-	150	358	133	133	32	-
112-14M-115	112			5	499.11	496.32	-	150	456	133	133	32	-		
144-14M-115	144			5	641.71	638.92	-	165	600	133	133	32	-		
168-14M-115	168			5	748.66	745.87	-	165	706	133	133	32	-		
192-14M-115	192			5	855.62	852.82	-	165	813	133	133	32	-		
*216-14M-115	216			5	962.57	959.76	-	165	920	133	133	32	-		

HTD[®] 14M 170

CHARACTERISTICS	TYPE	No. of TEETH	EXEC.	Dp PITCH LINE	De EXTERNAL	Df FLANGE	Dm HUB	Di	F	L	d bore Ø	FLANGE No.			
STEEL	WITH FLANGE	28-14M-170	28	1F	124.78	122.12	128	100	-	187	202	-	153		
		*29-14M-170	29	1F	129.23	126.57	138	100	-	187	202	-	154		
		30-14M-170	30	1F	133.69	130.99	138	100	-	187	202	-	154		
		32-14M-170	32	1F	142.60	139.88	154	100	-	187	202	-	160		
		34-14M-170	34	1F	151.52	148.79	160	100	-	187	202	-	166		
		36-14M-170	36	1F	160.43	157.68	168	120	-	187	202	-	168		
		38-14M-170	38	1F	169.34	166.60	183	135	-	187	202	-	172		
		40-14M-170	40	1F	178.25	175.49	188	140	-	187	202	-	162		
		*44-14M-170	44	1F	196.08	193.28	211	160	-	187	202	-	175		
		*48-14M-170	48	1F	213.90	211.11	226	160	-	187	202	-	180		
		*56-14M-170	56	1F	249.55	246.76	256	160	-	187	202	-	182		
		*64-14M-170	64	1F	285.21	282.41	296	180	-	187	202	-	184		
		CAST IRON	WITHOUT FLANGE	*72-14M-170	72	7	320.86	318.06	-	180	278	187	187	32	-
				80-14M-170	80	7	356.51	353.71	-	180	314	187	187	32	-
				90-14M-170	90	5	401.07	398.28	-	180	358	187	187	38	-
112-14M-170	112			5	499.11	496.32	-	200	456	187	187	38	-		
144-14M-170	144			5	641.71	638.92	-	220	600	187	187	38	-		
168-14M-170	168			5	748.66	745.87	-	220	706	187	187	38	-		
*192-14M-170	192			5	855.61	852.82	-	220	813	187	187	38	-		
*216-14M-170	216			5	962.57	959.76	-	220	920	187	187	38	-		

* Toothings marked with an asterisk are produced on request

HTD® "PHOSPHATED" PULLEYS

TAPER-LOCK®

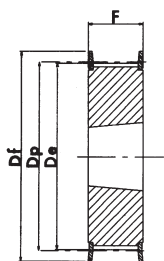

EXECUTION 1F

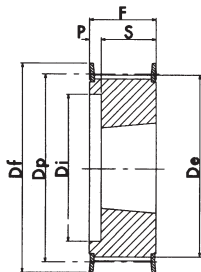

EXECUTION 2F

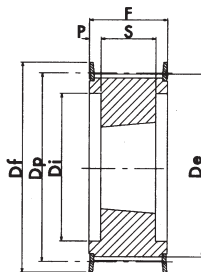

EXECUTION 3F

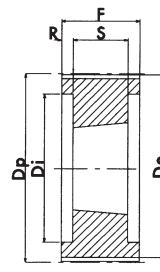

EXECUTION 4

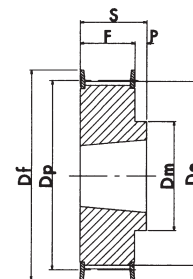

EXECUTION 5F

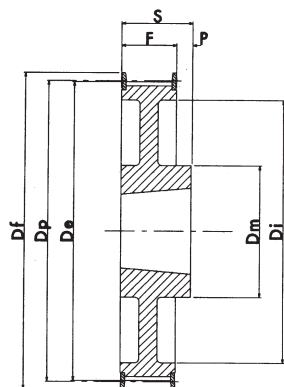

EXECUTION 6F

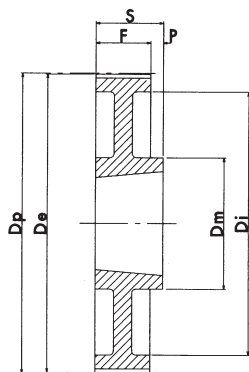

EXECUTION 7

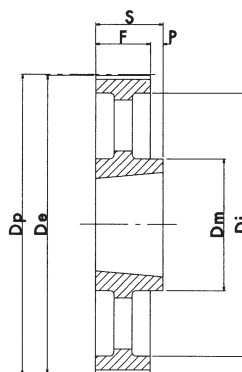

EXECUTION 8

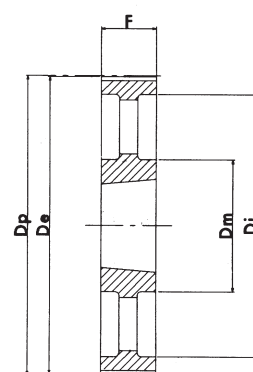

EXECUTION 9

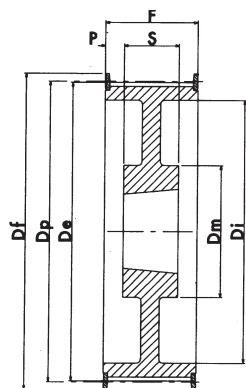

EXECUTION 10F

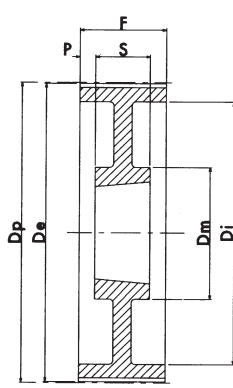

EXECUTION 11

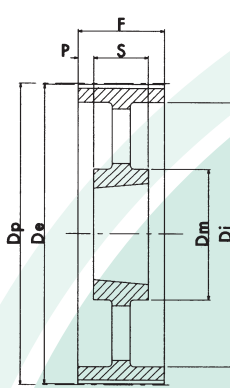

EXECUTION 12

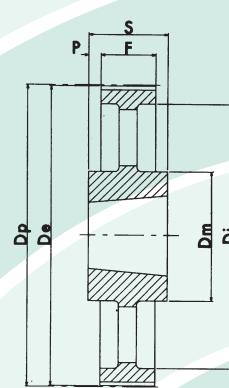

EXECUTION 13

HTD® "PHOSPHATED" PULLEYS TAPER-LOCK®

HTD® 5M 15

CHARACTERISTICS		TYPE	No. of TEETH	EXEC.	BUSH	MAX. BORE	Dp PITCH LINE	De EXTERNAL	Df FLANGE	Dm HUB	Di	F	S	P	FLANGE No.
STEEL	WITH FLANGE	TL 34-5M-15	34	1F	1008	25	54.11	52.97	57	-	-	22	22	-	20
		TL 36-5M-15	36	1F	1108	25	57.30	56.15	60	-	-	22	22	-	21
		TL 38-5M-15	38	1F	1108	25	60.48	59.34	66.5	-	-	22	22	-	24
		TL 40-5M-15	40	1F	1108	25	63.66	62.52	71	-	-	22	22	-	25
		TL 44-5M-15	44	1F	1108	25	70.03	68.89	75	-	-	22	22	-	27
		TL 48-5M-15	48	5F	1210	32	76.39	75.25	83	59	-	22	25	3	29
		TL 56-5M-15	56	5F	1210	32	89.13	87.39	93	70	-	22	25	3	33
		TL 64-5M-15	64	5F	1210	32	101.86	100.72	106	80	-	22	25	3	38
	WITHOUT FLANGE	TL 72-5M-15	72	5	1610	42	114.59	113.45	-	92	-	22	25	3	-
		TL 80-5M-15	80	5	1610	42	127.32	126.18	-	92	-	22	25	3	-
		TL 90-5M-15	90	5	1610	42	143.24	142.10	-	92	-	22	25	3	-
		TL112-5M-15	112	5	2012	50	178.25	177.11	-	110	-	20	32	12	-
		TL136-5M-15	136	13	2012	50	216.45	215.31	-	110	199	20	32	6	-

HTD® 8M 20

CHARACTERISTICS		TYPE	No. of TEETH	EXEC.	BUSH	MAX. BORE	Dp PITCH LINE	De EXTERNAL	Df FLANGE	Dm HUB	Di	F	S	P	FLANGE No.		
STEEL	WITH FLANGE	TL22-8M-20	22	2F	1008	25	56.02	54.65	60	-	37	28	22	6	53		
		TL24-8M-20	24	2F	1108	25	61.12	59.75	66	-	44	28	22	6	69		
		TL26-8M-20	26	2F	1108	25	66.21	64.85	70	-	45	28	22	6	61		
		TL28-8M-20	28	2F	1108	25	71.30	70.08	75	-	50	28	22	6	79		
		TL30-8M-20	30	2F	1108	25	76.39	75.13	83	-	58	28	22	6	73		
		TL32-8M-20	32	2F	1610	42	81.49	80.16	87	-	63	28	25	3	76		
		TL34-8M-20	34	2F	1610	42	86.58	85.22	91	-	64	28	25	3	66		
		TL36-8M-20	36	2F	1610	42	91.67	90.30	97	-	68	28	25	3	68		
		TL38-8M-20	38	2F	1610	42	96.77	95.39	102	-	72	28	25	3	70		
		TL40-8M-20	40	2F	1610	42	101.86	100.49	106	-	76	28	25	3	77		
		TL44-8M-20	44	5F	2012	50	112.05	110.67	120	92	-	28	32	4	75		
		TL48-8M-20	48	5F	2012	50	122.23	120.86	128	96	-	28	32	4	78		
		TL56-8M-20	56	5F	2012	50	142.60	141.23	150	110	-	28	32	4	85		
		TL64-8M-20	64	6F	2012	50	162.97	161.60	168	110	137	28	32	4	90		
		TL72-8M-20	72	6F	2012	50	183.35	181.97	192	110	158	28	32	4	97		
		CAST IRON	WITHOUT FLANGE	TL80-8M-20	80	7	2012	50	203.72	202.35	-	110	180	28	32	4	-
				TL90-8M-20	90	7	2012	50	229.18	227.81	-	110	204	28	32	4	-
TL112-8M-20	112			7	2517	60	285.21	283.83	-	125	254	28	45	17	-		
TL144-8M-20	144			13	2517	60	366.69	365.32	-	125	336	28	45	12	-		

HTD® "PHOSPHATED" PULLEYS TAPER-LOCK®

HTD® 8M 30

CHARACTERISTICS		TYPE	No. of TEETH	EXEC.	BUSH	MAX. BORE	Dp PITCH LINE	De EXTERNAL	Df FLANGE	Dm HUB	Di	F	S	P	FLANGE No.
STEEL	WITH FLANGE	TL 22-8M-30	22	2F	1008	25	56.02	54.65	60	-	37	38	22	16	53
		TL 24-8M-30	24	2F	1108	25	61.12	59.75	66	-	44	38	22	16	69
		TL 26-8M-30	26	2F	1108	25	66.21	64.85	70	-	44	38	22	16	61
		TL 28-8M-30	28	2F	1210	32	71.30	70.08	75	-	50	38	25	13	79
		TL 30-8M-30	30	1F	1615	42	76.39	75.13	83	-	-	38	38	-	73
		TL 32-8M-30	32	1F	1615	42	81.49	80.16	87	-	-	38	38	-	76
		TL 34-8M-30	34	1F	1615	42	86.58	85.22	91	-	-	38	38	-	66
		TL 36-8M-30	36	1F	1615	42	91.67	90.30	97	-	-	38	38	-	68
		TL 38-8M-30	38	1F	1615	42	96.77	95.39	102	-	-	38	38	-	70
		TL 40-8M-30	40	1F	1615	42	101.86	100.49	106	-	-	38	38	-	77
		TL 44-8M-30	44	2F	2012	50	112.05	110.67	120	-	86	38	32	6	75
		TL 48-8M-30	48	2F	2012	50	122.23	120.86	128	-	90	38	32	6	78
		TL 56-8M-30	56	2F	2012	50	142.60	141.23	150	-	110	38	32	6	85
		TL 64-8M-30	64	5F	2517	60	162.97	161.60	168	125	-	38	45	7	90
		TL 72-8M-30	72	6F	2517	60	183.35	181.97	192	125	158	38	45	7	97
CAST IRON	WITHOUT FLANGE	TL 80-8M-30	80	7	2517	60	203.72	202.35	-	125	180	38	45	7	-
		TL 90-8M-30	90	7	2517	60	229.18	227.81	-	125	204	38	45	7	-
		TL 112-8M-30	112	7	2517	60	285.21	283.83	-	125	254	38	45	7	-
		TL 144-8M-30	144	8	2517	60	366.69	365.32	-	125	336	38	45	7	-

HTD® 8M 50

CHARACTERISTICS		TYPE	No. of TEETH	EXEC.	BUSH	MAX. BORE	Dp PITCH LINE	De EXTERNAL	Df FLANGE	Dm HUB	Di	F	S	P	FLANGE No.
STEEL	WITH FLANGE	TL 28-8M-50	28	2F	1210	32	71.30	70.08	75	-	50	60	25	35	79
		TL 30-8M-50	30	2F	1615	42	76.39	75.13	83	-	58	60	38	22	73
		TL 32-8M-50	32	2F	1615	42	81.49	80.16	87	-	63	60	38	22	76
		TL 34-8M-50	34	2F	1615	42	86.58	85.22	91	-	65	60	38	22	66
		TL 36-8M-50	36	2F	1615	42	91.67	90.30	97	-	68	60	38	22	68
		TL 38-8M-50	38	2F	1615	42	96.77	95.39	102	-	72	60	38	22	70
		TL 40-8M-50	40	3F	2012	50	101.86	100.49	106	-	80	60	32	14	77
		TL 44-8M-50	44	3F	2012	50	112.05	110.67	120	-	86	60	32	14	75
		TL 48-8M-50	48	3F	2012	50	122.23	120.86	128	-	95	60	32	14	78
		TL 56-8M-50	56	3F	2517	60	142.60	141.23	150	-	116	60	45	7.5	85
		TL 64-8M-50	64	3F	2517	60	162.97	161.60	168	-	136	60	45	7.5	90
		TL 72-8M-50	72	10F	2517	60	183.35	181.97	192	125	158	60	45	7.5	97
CAST IRON	WITHOUT FLANGE	TL 80-8M-50	80	4	3020	75	203.72	202.3	-	-	180	60	51	4.5	-
		TL 90-8M-50	90	11	3020	75	229.18	227.81	-	160	204	60	51	4.5	-
		TL 112-8M-50	112	11	3020	75	285.21	283.83	-	170	254	60	51	4.5	-
		TL 144-8M-50	144	12	3020	75	366.69	365.32	-	170	336	60	51	4.5	-
		TL 168-8M-50	168	13	3525	90	427.81	426.44	-	198	395	60	65	2.5	-
		TL 192-8M-50	192	13	3525	90	488.92	487.55	-	198	455	60	65	2.5	-

HTD® "PHOSPHATED" PULLEYS TAPER-LOCK®

HTD® 8M 85

CHARACTERISTICS	TYPE	No. of TEETH	EXEC.	BUSH	MAX. BORE	Dp PITCH LINE	De EXTERNAL	Df FLANGE	Dm HUB	Di	F	S	P	FLANGE No.	
STEEL	WITH FLANGE	TL 34-8M-85	34	3F	1615	42	86.58	85.22	91	-	65	95	38	28.5	66
		TL 36-8M-85	36	3F	1615	42	91.67	90.30	97	-	68	95	38	28.5	68
		TL 38-8M-85	38	3F	1615	42	96.77	95.39	102	-	72	95	38	28.5	70
		TL 40-8M-85	40	3F	2012	50	101.86	100.49	106	-	80	95	32	31.5	77
		TL 44-8M-85	44	3F	2012	50	112.05	110.67	120	-	86	95	32	31.5	75
		TL 48-8M-85	48	3F	2517	60	122.23	120.86	128	-	97	95	45	25	78
		TL 56-8M-85	56	3F	2517	60	142.60	141.23	150	-	116	95	45	25	85
		TL 64-8M-85	64	3F	2517	60	162.97	161.60	168	-	136	95	45	25	90
		TL 72-8M-85	72	3F	3020	75	183.35	181.97	192	-	150	95	51	22	97
		CAST IRON	WITHOUT FLANGE	TL 80-8M-85	80	4	3020	75	203.72	202.35	-	-	180	95	51
TL 90-8M-85	90			4	3020	75	229.18	227.81	-	-	204	95	51	22	-
TL112-8M-85	112			11	3020	75	285.21	283.83	-	170	254	95	51	22	-
TL144-8M-85	144			11	3525	90	366.69	365.32	-	198	336	95	65	15	-
TL168-8M-85	168			12	3525	90	427.81	426.44	-	198	395	95	65	15	-
TL192-8M-85	192			12	3525	90	488.92	487.55	-	198	455	95	65	15	-

HTD® 14M 40

CHARACTERISTICS	TYPE	No. of TEETH	EXEC.	BUSH	MAX. BORE	Dp PITCH LINE	De EXTERNAL	Df FLANGE	Dm HUB	Di	F	S	P	FLANGE No.			
STEEL	WITH FLANGE	TL 28-14M-40	28	3F	2012	50	124.78	122.12	128	-	94	54	32	11	153		
		*TL 29-14M-40	29	3F	2012	50	129.23	126.57	138	-	98	54	32	11	154		
		TL 30-14M-40	30	3F	2012	50	133.69	130.99	138	-	98	54	32	11	154		
		TL 32-14M-40	32	3F	2012	50	142.60	139.88	154	-	108	54	32	11	160		
		TL 34-14M-40	34	3F	2517	60	151.52	148.79	160	-	110	54	45	4.5	166		
		TL 36-14M-40	36	3F	2517	60	160.43	157.68	168	-	120	54	45	4.5	168		
		TL 38-14M-40	38	3F	2517	60	169.34	166.60	183	-	130	54	45	4.5	172		
		TL 40-14M-40	40	3F	2517	60	178.25	175.49	188	-	138	54	45	4.5	162		
		TL 44-14M-40	44	3F	3020	75	196.08	193.28	211	-	155	54	51	1.5	175		
		TL 48-14M-40	48	3F	3020	75	213.90	211.11	226	-	170	54	51	1.5	180		
		TL 56-14M-40	56	3F	3020	75	249.55	246.76	256	-	208	54	51	1.5	182		
		*TL 64-14M-40	64	10F	3020	75	285.21	282.41	296	170	240	54	51	1.5	184		
		CAST IRON	WITHOUT FLANGE	TL 72-14M-40	72	11	3020	75	320.86	318.06	-	170	280	54	51	1.5	-
				TL 80-14M-40	80	12	3020	75	356.51	353.71	-	170	315	54	51	1.5	-
TL 90-14M-40	90			12	3020	75	401.07	398.28	-	170	360	54	51	1.5	-		
TL 112-14M-40	112			12	3020	75	499.11	496.32	-	170	457	54	51	1.5	-		
TL 144-14M-40	144			12	3020	75	641.71	638.92	-	170	600	54	51	1.5	-		
TL 168-14M-40	168			12	3020	75	748.66	745.87	-	170	706	54	51	1.5	-		
TL 192-14M-40	192			12	3020	75	855.62	852.82	-	170	813	54	51	1.5	-		
TL 216-14M-40	216			12	3020	75	962.57	959.76	-	170	920	54	51	1.5	-		
TL 264-14M-40	264			13	4040	100	1176.47	1173.66	-	230	1133	54	102	24	-		

* Toothings marked with an asterisk are produced on request

HTD® "PHOSPHATED" PULLEYS TAPER-LOCK®

HTD® 14M 55

CHARACTERISTICS	TYPE	No. of TEETH	EXEC.	BUSH	MAX. BORE	Dp PITCH LINE	De EXTERNAL	Df FLANGE	Dm HUB	Di	F	S	P	FLANGE No.			
STEEL	WITH FLANGE	TL 28-14M-55	28	3F	2012	50	124.78	122.12	128	-	94	70	32	19	153		
		*TL 29-14M-55	29	3F	2012	50	129.23	126.57	138	-	100	70	32	19	154		
		TL 30-14M-55	30	3F	2517	60	133.69	130.99	138	-	100	70	45	12.5	154		
		TL 32-14M-55	32	3F	2517	60	142.60	139.88	154	-	108	70	45	12.5	160		
		TL 34-14M-55	34	3F	2517	60	151.52	148.79	160	-	110	70	45	12.5	166		
		TL 36-14M-55	36	3F	2517	60	160.43	157.68	168	-	120	70	45	12.5	168		
		TL 38-14M-55	38	3F	2517	60	169.34	166.60	183	-	130	70	45	12.5	172		
		TL 40-14M-55	40	3F	2517	60	178.25	175.49	188	-	138	70	45	12.5	162		
		TL 44-14M-55	44	3F	3020	75	196.08	193.28	211	-	155	70	51	9.5	175		
		TL 48-14M-55	48	3F	3020	75	213.90	211.11	226	-	170	70	51	9.5	180		
		TL 56-14M-55	56	3F	3020	75	249.55	246.76	256	-	208	70	51	9.5	182		
		TL 64-14M-55	64	10F	3020	75	285.21	282.41	296	170	240	70	51	9.5	184		
		CAST IRON	WITHOUT FLANGE	TL 72-14M-55	72	11	3020	75	320.86	318.06	-	170	280	70	51	9.5	-
				TL 80-14M-55	80	12	3020	75	356.51	353.71	-	170	315	70	51	9.5	-
TL 90-14M-55	90			12	3020	75	401.07	398.28	-	170	360	70	51	9.5	-		
TL 112-14M-55	112			12	3020	75	499.11	496.32	-	170	457	70	51	9.5	-		
TL 144-14M-55	144			12	3020	75	641.71	638.92	-	170	600	70	51	9.5	-		
TL 168-14M-55	168			12	3020	75	748.66	745.87	-	170	706	70	51	9.5	-		
TL 192-14M-55	192			12	3020	75	855.62	852.82	-	170	813	70	51	9.5	-		
TL 216-14M-55	216			13	3535	90	962.57	959.76	-	190	920	70	89	9.5	-		
TL 264-14M-55	264			13	4040	100	1176.47	1173.66	-	230	1133	70	102	16	-		

HTD® 14M 85

CHARACTERISTICS	TYPE	No. of TEETH	EXEC.	BUSH	MAX. BORE	Dp PITCH LINE	De EXTERNAL	Df FLANGE	Dm HUB	Di	F	S	P	FLANGE No.			
STEEL	WITH FLANGE	TL28-14M-85	28	3F	2517	60	124.78	122.12	128	-	98	102	45	28.5	153		
		*TL29-14M-85	29	3F	2517	60	129.23	126.57	138	-	100	102	45	28.5	154		
		TL30-14M-85	30	3F	2517	60	133.69	130.99	138	-	100	102	45	28.5	154		
		TL32-14M-85	32	3F	2517	60	142.60	139.88	154	-	108	102	45	28.5	160		
		TL34-14M-85	34	3F	2517	60	151.52	148.79	160	-	110	102	45	28.5	166		
		TL36-14M-85	36	3F	3020	75	160.43	157.68	168	-	125	102	51	25.5	168		
		TL38-14M-85	38	3F	3020	75	169.34	166.60	183	-	130	102	51	25.5	172		
		TL40-14M-85	40	3F	3020	75	178.25	175.49	188	-	138	102	51	25.5	162		
		TL44-14M-85	44	3F	3020	75	196.08	193.28	211	-	153	102	51	25.5	175		
		TL48-14M-85	48	3F	3020	75	213.90	211.11	226	-	171	102	51	25.5	180		
		TL56-14M-85	56	3F	3525	90	249.55	246.76	256	-	210	102	65	18.5	182		
		TL64-14M-85	64	10F	3525	90	285.21	282.41	296	190	240	102	65	18.5	184		
		CAST IRON	WITHOUT FLANGE	TL72-14M-85	72	11	3525	90	320.86	318.06	-	190	280	102	65	18.5	-
				TL80-14M-85	80	12	3525	90	356.51	353.71	-	190	315	102	65	18.5	-
TL90-14M-85	90			12	3525	90	401.07	398.28	-	190	360	102	65	18.5	-		
TL112-14M-85	112			12	3525	90	499.11	496.32	-	190	457	102	65	18.5	-		
TL144-14M-85	144			12	3525	90	641.71	638.92	-	190	600	102	65	18.5	-		
TL168-14M-85	168			12	3525	90	748.66	745.87	-	190	706	102	65	18.5	-		
TL192-14M-85	192			9	4040	100	855.62	852.82	-	230	813	102	102	-	-		
TL216-14M-85	216			9	4040	100	962.57	959.76	-	230	920	102	102	-	-		
TL264-14M-85	264			9	4040	100	1176.47	1173.66	-	230	1133	102	102	-	-		

* Toothings marked with an asterisk are produced on request

HTD® "PHOSPHATED" PULLEYS TAPER-LOCK®

HTD® 14M 115

CHARACTERISTICS	TYPE	No. of TEETH	EXEC.	BUSH	MAX. BORE	Dp PITCH LINE	De EXTERNAL	Df FLANGE	Dm HUB	Di	F	S	P	FLANGE No.		
STEEL	WITH FLANGE	TL28-14M-115	28	3F	2517	60	124.78	122.12	128	-	98	133	45	44	153	
		*TL29-14M-115	29	3F	2517	60	129.23	126.57	138	-	100	133	45	44	154	
		TL30-14M-115	30	3F	2517	60	133.69	130.99	138	-	100	133	45	44	154	
		TL32-14M-115	32	3F	2517	60	142.60	139.88	154	-	108	133	45	44	160	
		TL34-14M-115	34	3F	2517	60	151.52	148.79	160	-	110	133	45	44	166	
		TL36-14M-115	36	3F	3020	75	160.43	157.68	168	-	125	133	51	41	168	
		TL38-14M-115	38	3F	3020	75	169.34	166.60	183	-	130	133	51	41	172	
	TL40-14M-115	40	3F	3020	75	178.25	175.49	188	-	138	133	51	41	162		
	TL44-14M-115	44	3F	3030	75	196.08	193.28	211	-	155	133	76	28.5	175		
	TL48-14M-115	48	3F	3030	75	213.90	211.11	226	-	170	133	76	28.5	180		
	TL56-14M-115	56	3F	3535	90	249.55	246.76	256	-	210	133	89	22	182		
	TL64-14M-115	64	10F	3535	90	285.21	282.41	296	190	240	133	89	22	184		
	CAST IRON	WITHOUT FLANGE	TL72-14M-115	72	11	3535	90	320.86	318.06	-	190	280	133	89	22	-
			TL80-14M-115	80	12	3535	90	356.51	353.71	-	190	315	133	89	22	-
TL90-14M-115			90	12	3535	90	401.07	398.28	-	190	360	133	89	22	-	
TL 112-14M-115			112	12	3535	90	499.11	496.32	-	190	457	133	89	22	-	
TL 144-14M-115			144	12	4040	100	641.71	638.92	-	230	600	133	102	15.5	-	
TL 168-14M-115			168	12	4040	100	748.66	745.87	-	230	706	133	102	15.5	-	
TL 192-14M-115		192	12	4040	100	855.62	852.82	-	230	813	133	102	15.5	-		
*TL 216-14M-115		216	12	4040	100	962.57	959.76	-	230	920	133	102	15.5	-		

HTD® 14M 170

CHARACTERISTICS	TYPE	No. of TEETH	EXEC.	BUSH	MAX. BORE	Dp PITCH LINE	De EXTERNAL	Df FLANGE	Dm HUB	Di	F	S	P	FLANGE No.	
STEEL	WITH FLANGE	TL38-14M-170	38	3F	3030	75	169.34	166.60	183	-	130	187	76	55.5	172
		TL40-14M-170	40	3F	3030	75	178.25	175.49	188	-	138	187	76	55.5	162
		TL44-14M-170	44	3F	3535	90	196.08	193.28	211	-	155	187	89	49	175
		TL48-14M-170	48	3F	3535	90	213.90	211.11	226	-	175	187	89	49	180
		*TL56-14M-170	56	3F	3535	90	249.55	246.76	256	-	210	187	89	49	182
		*TL64-14M-170	64	3F	4040	100	285.21	282.41	296	-	240	187	102	42.5	184
CAST IRON	WITHOUT FLANGE	*TL72-14M-170	72	11	4040	100	320.86	318.06	-	230	280	187	102	42.5	-
		TL80-14M-170	80	11	4040	100	356.51	353.71	-	230	315	187	102	42.5	-
		TL90-14M-170	90	12	4040	100	401.07	398.28	-	230	360	187	102	42.5	-
		TL112-14M-170	112	12	5050	125	499.11	496.32	-	265	457	187	127	30	-
		TL144-14M-170	144	12	5050	125	641.71	638.92	-	265	600	187	127	30	-
		TL168-14M-170	168	12	5050	125	748.66	745.87	-	265	706	187	127	30	-
		*TL192-14M-170	192	12	5050	125	855.62	852.82	-	265	813	187	127	30	-
		*TL216-14M-170	216	12	5050	125	962.57	959.76	-	265	920	187	127	30	-

* Toothings marked with an asterisk are produced on request

POWERGRIP® HTD® BARS

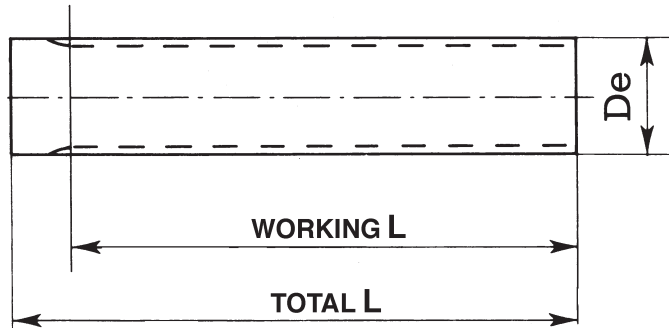

HTD 5M (5 mm pitch)

DESCRIPTION	No. of TEETH	Dp PITCH LINE	De EXTERNAL	L WORKING	L TOTAL
5M-12	12	19.10	17.96	150	160
5M-13	13	20.69	19.55	150	160
5M-14	14	22.28	21.14	175	200
5M-15	15	23.87	22.73	175	200
5M-16	16	25.47	24.33	175	200
5M-17	17	27.06	25.92	175	200
5M-18	18	28.65	27.51	-	200
5M-19	19	30.24	29.10	-	200
5M-20	20	31.83	30.69	-	200
5M-21	21	33.42	32.28	-	200
5M-22	22	35.02	33.88	-	200
5M-23	23	36.61	35.47	-	200
5M-24	24	38.20	37.06	-	200
5M-25	25	39.79	38.65	-	200
5M-26	26	41.38	40.24	-	200
5M-27	27	42.97	41.83	-	200
5M-28	28	44.56	43.42	-	200
5M-30	30	47.75	46.61	-	200
5M-32	32	50.93	49.79	-	200
5M-34	34	54.11	52.97	-	200
5M-36	36	57.30	56.16	-	200
5M-38	38	60.48	59.34	-	200
5M-40	40	63.66	62.52	-	200
5M-42	42	66.85	65.71	-	200
5M-44	44	70.03	68.89	-	200
5M-45	45	71.62	70.48	-	200
5M-48	48	76.40	75.26	-	200
5M-50	50	79.58	78.44	-	200
5M-60	60	95.50	94.36	-	200
5M-72	72	114.59	113.45	-	200

HTD 8M (8 mm pitch)

DESCRIPTION	No. of TEETH	Dp PITCH LINE	De EXTERNAL	L TOTAL
8M-18	18	45.84	44.47	200
8M-19	19	48.38	47.01	200
8M-20	20	50.93	49.56	200
8M-21	21	53.48	52.11	200
8M-22	22	56.02	54.65	200
8M-23	23	58.57	57.20	200
8M-24	24	61.12	59.75	200
8M-25	25	63.66	62.29	200
8M-26	26	66.21	64.84	200
8M-28	28	71.30	69.93	200
8M-30	30	76.40	75.03	200
8M-32	32	81.49	80.12	200
8M-34	34	86.58	85.21	200
8M-35	35	89.13	87.76	200
8M-36	36	91.68	90.31	200
8M-38	38	96.77	95.40	200
8M-40	40	101.86	100.49	200
8M-44	44	112.05	110.67	200
8M-48	48	122.23	120.86	200

Material: Aluminium suitable for hard anodising

Material: Steel C 40 UNI 7845

POWERGRIP® - GT® BELTS

The POWERGRIP® - GT® range of belts represents the natural development of the HTD® curved profile belts.

The use of new materials has enabled better performance to be achieved, new production technologies ensure consistent optimum quality, new profiles ensure greater precision and silent operation.

The POWERGRIP® - GT® range of belts can only operate in pulleys that have their specific profile.

These pulleys are manufactured having the following pitches: 2 - 3 - 5 mm; **CHIARAVALLI Trasmissioni S.p.A.** produce bars and pulleys having the following pitches: 3 and 5mm.

The applications of the POWERGRIP® - GT® range of belts are virtually unlimited but they are mainly recommended for the following:

- good power transmission in limited spaces - for example: electrical household appliances
- silent operation - for example: various office machines
- consistent precision - for example: machine tools and robots

Belt characteristics

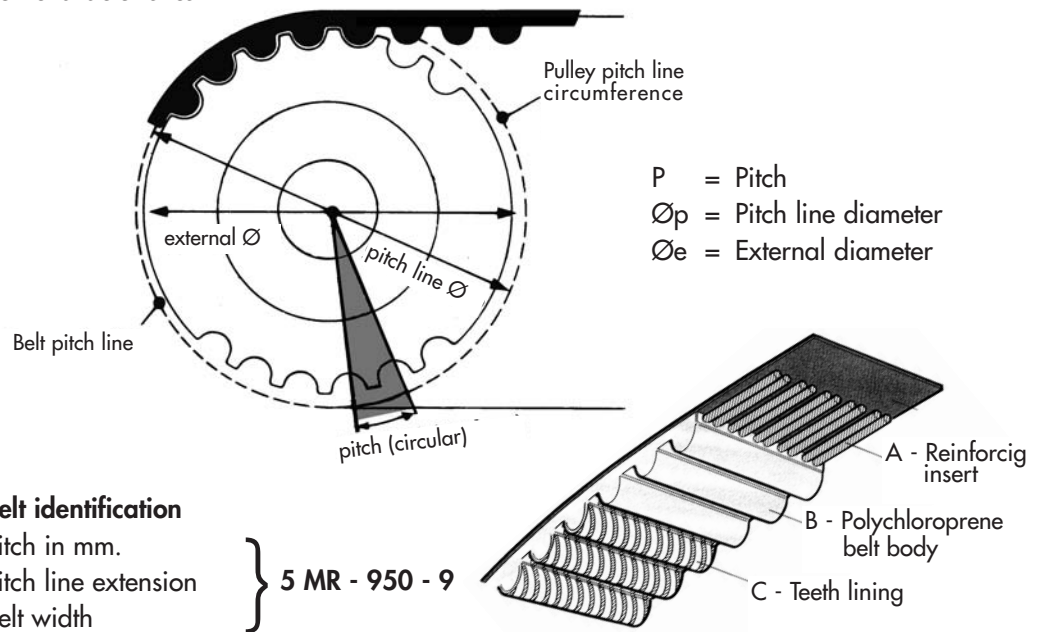

GT® 3MR

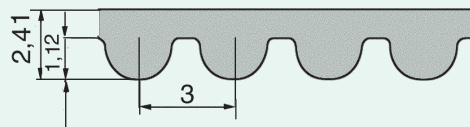

GT® 5MR

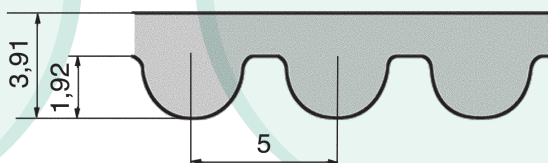

POWERGRIP® GT® "GATES®" BELTS

Belt tolerances along the pitch line length are limited, to achieve the correct belt tension therefore, it is necessary to be able to adjust the centres distance or tension the belt using a tensioning roller.

POWERGRIP® - GT® BELT PITCH SELECTION

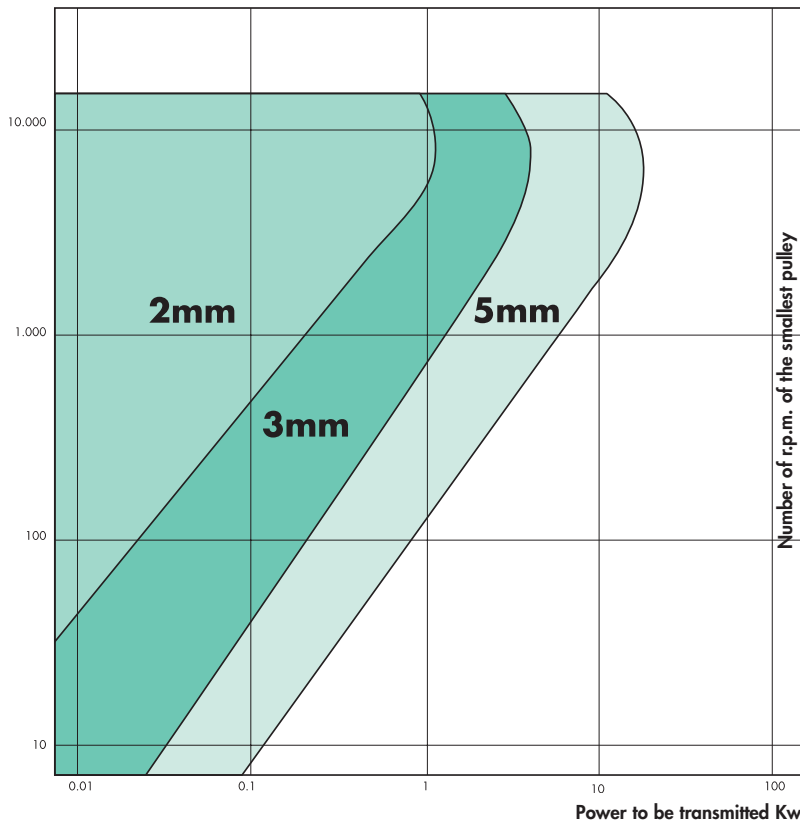

"GATES" GT® 3MR (3mm. pitch)

No. of Teeth	Pitch line length	Belt type
40	120	3MR 120
50	150	3MR 150
55	165	3MR 165
60	180	3MR 180
65	195	3MR 195
70	210	3MR 210
75	225	3MR 225
80	240	3MR 240
84	252	3MR 252
85	255	3MR 255
90	270	3MR 270
95	285	3MR 285
100	300	3MR 300
110	330	3MR 330
120	360	3MR 360
130	390	3MR 390
140	420	3MR 420
150	450	3MR 450
160	480	3MR 480
170	510	3MR 510
180	540	3MR 540
190	570	3MR 570
200	600	3MR 600

"GATES" GT® 5MR (5mm. pitch)

No. of Teeth	Pitch line length	Belt type
55	275	5MR 275
65	325	5MR 325
70	350	5MR 350
75	375	5MR 375
80	400	5MR 400
85	425	5MR 425
90	450	5MR 450
95	475	5MR 475
100	500	5MR 500
105	525	5MR 525
106	530	5MR 530
110	550	5MR 550
120	600	5MR 600
130	650	5MR 650
140	700	5MR 700
150	750	5MR 750
160	800	5MR 800
170	850	5MR 850
180	900	5MR 900
190	950	5MR 950
200	1000	5MR 1000
230	1150	5MR 1150
420	2100	5MR 2100

POWER GRIP® - GT® BELT WIDTHS

PITCH	GT 3MR	GT 5MR
BELT WIDTHS mm.	6 9 15	9 15 25

TOLERANCES ON CENTRES DISTANCES

These values can be found when the belt is subjected to a measurement load.

BELTS PITCH LINE LENGTH	TOLERANCE ON CENTRES DISTANCE mm
from 127 to 254	±0.2
from 255 to 381	±0.23
from 382 to 508	±0.25
from 509 to 762	±0.30
from 763 to 1016	±0.33
from 1017 to 1270	±0.38
from 1271 to 1524	±0.41
from 1525 to 1778	±0.43
longer than 1779	add ± 0.03 for every 250 mm. of additional length.

TOLERANCES ON GT® BELTS LENGTH

BELT WIDTH	TOLERANCE mm. FOR LENGTHS from 0 to 500	TOLERANCE mm. FOR LENGTHS from 501 to 1500	TOLERANCE mm. FOR LENGTHS from 1500 and longer
Up to 5	+ 0.4 - 0.4	+ 0.5 - 0.5	-
from 5.01 to 15	+ 0.6 - 0.6	+ 0.7 - 0.7	+ 0.8 - 0.8
from 15.01 to 25	+ 0.7 - 0.7	+ 0.8 - 0.8	+ 0.9 - 0.9
from 25.01 to 40	+ 0.8 - 0.8	+ 1.0 - 1.0	+ 1.2 - 1.2
from 40.01 to 55	+ 1.0 - 1.0	+ 1.2 - 1.2	+ 1.4 - 1.4
from 55.01 to 75	+ 1.2 - 1.2	+ 1.5 - 1.5	+ 1.8 - 1.8
from 75.01 to 100	+ 1.6 - 1.6	+ 1.8 - 1.8	+ 2.0 - 2.0
from 100.01 to 175	+ 2.4 - 2.4	+ 2.6 - 2.6	+ 2.8 - 2.8
longer than 175.01	-	-	+ 5.6 - 5.6

PILOT BORE "PHOSPHATED" POWERGRIP® GT® PULLEYS

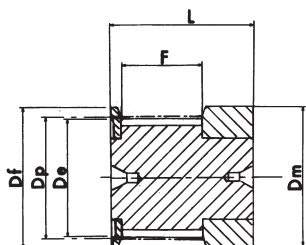

EXECUTION 0F

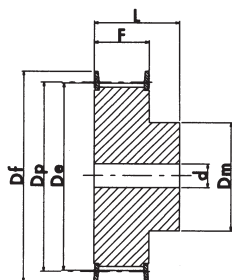

EXECUTION 1F

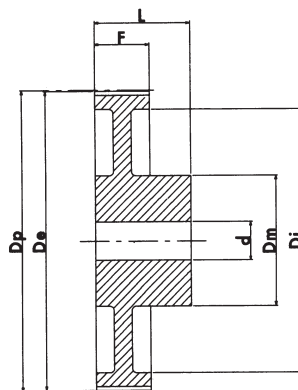

EXECUTION 3

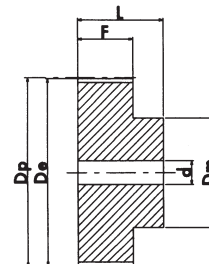

EXECUTION 8

GT® 3MR 09

CHARACTERISTICS	TYPE	No. of TEETH	EXEC.	Dp PITCH LINE	De EXTERNAL	Df FLANGE	Dm HUB	F	L	d bore Ø	FLANGE No.	
STEEL	WITH FLANGE	*10-3MR-09	10	0F	9.55	8.79	13.0	13.0	10.2	17.5	-	501
		12-3MR-09	12	0F	11.46	10.70	15.0	15.0	10.2	17.5	-	502
		*14-3MR-09	14	0F	13.37	12.61	16.0	16.0	10.2	17.5	-	503
		15-3MR-09	15	0F	14.32	13.56	17.5	17.5	10.2	17.5	-	516
		*16-3MR-09	16	1F	15.28	14.52	17.5	10.0	12.8	20.6	4	504
		18-3MR-09	18	1F	17.19	16.43	20.0	11.0	12.8	20.6	6	505
		20-3MR-09	20	1F	19.10	18.34	23.0	13.0	12.8	20.6	6	517
		*21-3MR-09	21	1F	20.05	19.29	25.0	14.0	12.8	20.6	6	518
		22-3MR-09	22	1F	21.01	20.25	25.0	14.0	12.8	20.6	6	518
		*24-3MR-09	24	1F	22.92	22.16	25.0	14.0	12.8	20.6	6	518
	26-3MR-09	26	1F	24.83	24.07	28.0	16.0	12.8	20.6	6	508	
	28-3MR-09	28	1F	26.74	25.98	32.0	18.0	12.8	20.6	6	509	
	30-3MR-09	30	1F	28.65	27.89	32.0	20.0	12.8	20.6	6	509	
	32-3MR-09	32	1F	30.56	29.80	36.0	22.0	12.8	20.6	6	510	
	36-3MR-09	36	1F	34.38	33.62	39.0	26.0	13.4	22.2	6	519	
	40-3MR-09	40	1F	38.20	37.44	42.0	28.0	13.4	22.2	6	513	
	44-3MR-09	44	1F	42.02	41.26	48.0	33.0	13.4	22.2	6	520	
	WITHOUT FLANGE	48-3MR-09	48	8	45.84	45.08	-	33.0	13.4	22.2	8	-
	60-3MR-09	60	8	57.30	56.54	-	33.0	13.4	22.2	8	-	
	72-3MR-09	72	8	68.75	67.99	-	33.0	13.4	22.2	8	-	

* Toothings marked with an asterisk are produced on request

PILOT BORE " PHOSPHATED " POWERGRIP® GT® PULLEYS

GT® 3MR 15

CHARACTERISTICS	TYPE	No. of TEETH	EXEC.	Dp PITCH LINE	De EXTERNAL	Df FLANGE	Dm HUB	F	L	d bore Ø	FLANGE No.	
STEEL	WITH FLANGE	*10-3MR-15	10	OF	9.55	8.79	13.0	13.0	17.0	26.0	-	501
		12-3MR-15	12	OF	11.46	10.70	15.0	15.0	17.0	26.0	-	502
		*14-3MR-15	14	OF	13.37	12.61	16.0	16.0	17.0	26.0	-	503
		15-3MR-15	15	OF	14.32	13.56	17.5	17.5	17.0	26.0	-	516
		*16-3MR-15	16	1F	15.28	14.52	17.5	10.0	19.5	26.0	4	504
		18-3MR-15	18	1F	17.19	16.43	20.0	11.0	19.5	26.0	6	505
		20-3MR-15	20	1F	19.10	18.34	23.0	13.0	19.5	26.0	6	517
		*21-3MR-15	21	1F	20.05	19.29	25.0	14.0	19.5	26.0	6	518
		22-3MR-15	22	1F	21.01	20.25	25.0	14.0	19.5	26.0	6	518
		*24-3MR-15	24	1F	22.92	22.16	25.0	14.0	19.5	26.0	6	518
		26-3MR-15	26	1F	24.83	24.07	28.0	16.0	19.5	26.0	6	508
		28-3MR-15	28	1F	26.74	25.98	32.0	18.0	19.5	26.0	6	509
		30-3MR-15	30	1F	28.65	27.89	32.0	20.0	19.5	26.0	6	509
		32-3MR-15	32	1F	30.56	29.80	36.0	22.0	19.5	26.0	6	510
	36-3MR-15	36	1F	34.38	33.62	39.0	26.0	20.0	30.0	6	519	
	40-3MR-15	40	1F	38.20	37.44	42.0	28.0	20.0	30.0	6	513	
	44-3MR-15	44	1F	42.02	41.26	48.0	33.0	20.0	30.0	6	520	
	WITHOUT FLANGE	48-3MR-15	48	8	45.84	45.08	-	33.0	20.0	30.0	8	-
		60-3MR-15	60	8	57.30	56.54	-	33.0	20.0	30.0	8	-
		72-3MR-15	72	8	68.75	67.99	-	33.0	20.0	30.0	8	-

GT® 5MR 09

CHARACTERISTICS	TYPE	No. of TEETH	EXEC.	Dp PITCH LINE	De EXTERNAL	Df FLANGE	Dm HUB	Di	F	L	d bore Ø	FLANGE No.	
STEEL	WITH FLANGE	12-5MR-09	12	1F	19.10	17.96	23.0	13.0	-	14.5	20.0	-	14
		*14-5MR-09	14	1F	22.28	21.14	25.0	14.0	-	14.5	20.0	6	2
		15-5MR-09	15	1F	23.87	22.73	28.0	16.0	-	14.5	20.0	6	4
		16-5MR-09	16	1F	25.46	24.32	28.0	16.5	-	14.5	20.0	6	4
		18-5MR-09	18	1F	28.65	27.51	32.0	20.0	-	14.5	20.0	6	6
		20-5MR-09	20	1F	31.83	30.69	36.0	23.0	-	14.5	22.5	6	8
		*21-5MR-09	21	1F	33.42	32.28	38.0	24.0	-	14.5	22.5	6	9
		22-5MR-09	22	1F	35.01	33.87	39.0	25.5	-	14.5	22.5	6	15
		24-5MR-09	24	1F	38.20	37.06	42.0	27.0	-	14.5	22.5	6	13
		26-5MR-09	26	1F	41.38	40.24	44.0	30.0	-	14.5	22.5	6	12
		28-5MR-09	28	1F	44.56	43.42	48.0	30.5	-	14.5	22.5	6	11
		30-5MR-09	30	1F	47.75	46.60	51.0	35.0	-	14.5	22.5	6	16
		32-5MR-09	32	1F	50.93	49.79	54.0	38.0	-	14.5	22.5	8	18
		36-5MR-09	36	1F	57.30	56.16	60.0	38.0	-	14.5	22.5	8	21
	40-5MR-09	40	1F	63.66	62.52	71.0	38.0	-	14.5	22.5	8	25	
	WITHOUT FLANGE	44-5MR-09	44	3	70.03	68.89	-	38.0	54	14.5	25.5	8	-
		48-5MR-09	48	3	76.39	75.25	-	45.0	61	14.5	25.5	8	-
		60-5MR-09	60	3	95.49	94.35	-	45.0	80	14.5	25.5	8	-
		72-5MR-09	72	3	114.59	113.45	-	45.0	100	14.5	25.5	8	-

* Toothings marked with an asterisk are produced on request

PILOT BORE " PHOSPHATED " POWERGRIP® GT® PULLEYS

GT® 5MR 15

CHARACTERISTICS	TYPE	No. of TEETH	EXEC.	Dp PITCH LINE	De EXTERNAL	Df FLANGE	Dm HUB	Di	F	L	d bore Ø	FLANGE No.	
STEEL	WITH FLANGE	12-5MR-15	12	1F	19.10	17.96	23.0	13.0	-	20.5	26.0	-	14
		*14-5MR-15	14	1F	22.28	21.14	25.0	14.0	-	20.5	26.0	6	2
		15-5MR-15	15	1F	23.87	22.73	28.0	16.0	-	20.5	26.0	6	4
		16-5MR-15	16	1F	25.46	24.32	28.0	16.5	-	20.5	26.0	6	4
		8-5MR-15	18	1F	28.65	27.51	32.0	20.0	-	20.5	26.0	6	6
		20-5MR-15	20	1F	31.83	30.69	36.0	23.0	-	20.5	26.0	6	8
		*21-5MR-15	21	1F	33.42	32.28	38.0	24.0	-	20.5	26.0	6	9
		22-5MR-15	22	1F	35.01	33.87	39.0	25.5	-	20.5	26.0	6	15
		24-5MR-15	24	1F	38.20	37.06	42.0	27.0	-	20.5	28.0	6	13
		26-5MR-15	26	1F	41.38	40.24	44.0	30.0	-	20.5	28.0	6	12
	28-5MR-15	28	1F	44.56	43.42	48.0	30.5	-	20.5	28.0	6	11	
	30-5MR-15	30	1F	47.75	46.60	51.0	35.0	-	20.5	28.0	6	16	
	32-5MR-15	32	1F	50.93	49.79	54.0	38.0	-	20.5	28.0	8	18	
	36-5MR-15	36	1F	57.30	56.16	60.0	38.0	-	20.5	28.0	8	21	
	40-5MR-15	40	1F	63.66	62.52	71.0	38.0	-	20.5	28.0	8	25	
	WITHOUT FLANGE	44-5MR-15	44	3	70.03	68.89	-	38.0	54	20.5	30.0	8	-
		48-5MR-15	48	3	76.39	75.25	-	38.0	61	20.5	30.0	8	-
		60-5MR-15	60	3	95.49	94.35	-	50.0	80	20.5	30.0	8	-
		72-5MR-15	72	3	114.59	113.45	-	50.0	100	20.5	30.0	8	-

GT® 5MR 25

CHARACTERISTICS	TYPE	No. of TEETH	EXEC.	Dp PITCH LINE	De EXTERNAL	Df FLANGE	Dm HUB	Di	F	L	d bore Ø	FLANGE No.	
STEEL	WITH FLANGE	*12-5MR-25	12	1F	19.10	17.96	23.0	13.0	-	30.5	36.0	-	14
		*14-5MR-25	14	1F	22.28	21.14	25.0	14.0	-	30.5	36.0	-	2
		*15-5MR-25	15	1F	23.87	22.73	28.0	16.0	-	30.5	36.0	-	4
		*16-5MR-25	16	1F	25.46	24.32	28.0	16.5	-	30.5	36.0	-	4
		*18-5MR-25	18	1F	28.65	27.51	32.0	20.0	-	30.5	36.0	-	6
		*20-5MR-25	20	1F	31.83	30.69	36.0	23.0	-	30.5	36.0	-	8
		*21-5MR-25	21	1F	33.42	32.28	38.0	24.0	-	30.5	38.0	-	9
		*22-5MR-25	22	1F	35.01	33.87	39.0	25.5	-	30.5	38.0	-	15
		*24-5MR-25	24	1F	38.20	37.06	42.0	27.0	-	30.5	38.0	-	13
		*26-5MR-25	26	1F	41.38	40.24	44.0	30.0	-	30.5	38.0	-	12
	*28-5MR-25	28	1F	44.56	43.42	48.0	30.5	-	30.5	38.0	-	11	
	*30-5MR-25	30	1F	47.75	46.60	51.0	35.0	-	30.5	38.0	-	16	
	*32-5MR-25	32	1F	50.93	49.79	54.0	38.0	-	30.5	38.0	-	18	
	*36-5MR-25	36	1F	57.30	56.16	60.0	38.0	-	30.5	38.0	-	21	
	*40-5MR-25	40	1F	63.66	62.52	71.0	38.0	-	30.5	38.0	-	25	
	WITHOUT FLANGE	*44-5MR-25	44	8	70.03	68.89	-	38.0	-	30.5	40.0	-	-
		*48-5MR-25	48	3	76.39	75.25	-	38.0	61	30.5	40.0	-	-
		*60-5MR-25	60	3	95.49	94.35	-	50.0	80	30.5	40.0	-	-
		*72-5MR-25	72	3	114.59	113.45	-	50.0	100	30.5	40.0	-	-

* Toothings marked with an asterisk are produced on request

POWERGRIP® GT® BARS

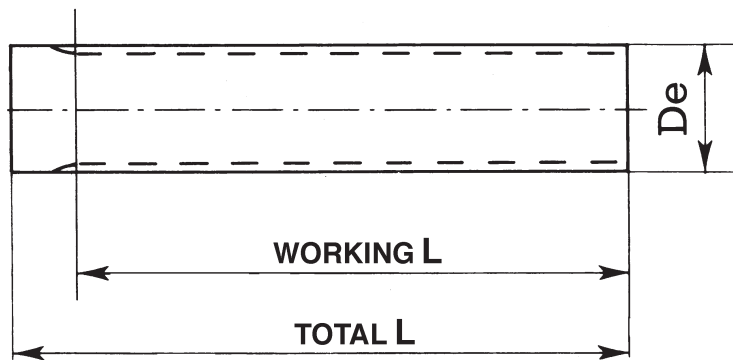

GT® 3MR

DESCRIPTION	No. of TEETH	Dp PITCH LINE	De EXTERNAL	L WORKING	L TOTAL
10-3MR	10	9.55	8.79	75	100
12-3MR	12	11.46	10.70	100	125
14-3MR	14	13.37	12.61	100	125
15-3MR	15	14.32	13.56	100	125
16-3MR	16	15.28	14.52	125	155
18-3MR	18	17.19	16.43	125	155
20-3MR	20	19.10	18.34	150	165
21-3MR	21	20.05	19.29	150	165
22-3MR	22	21.01	20.25	150	165
24-3MR	24	22.92	22.16	150	165
26-3MR	26	24.83	24.07	150	165
28-3MR	28	26.74	25.98	150	165
30-3MR	30	28.65	27.89	175	183
32-3MR	32	30.56	29.80	175	183
34-3MR	34	32.47	31.71	175	183
36-3MR	36	34.38	33.62	200	200
38-3MR	38	36.29	35.53	200	200
40-3MR	40	38.20	37.44	200	200
44-3MR	44	42.02	41.26	200	200
48-3MR	48	45.84	45.08	200	200
52-3MR	52	49.66	48.90	200	200
56-3MR	56	54.48	52.72	200	200
60-3MR	60	57.30	56.54	200	200
64-3MR	64	61.12	60.36	200	200
72-3MR	72	68.75	67.99	200	200

GT® 5MR

DESCRIPTION	No. of TEETH	Dp PITCH LINE	De EXTERNAL	L WORKING	L TOTAL
12-5MR	12	19.10	17.96	150	165
14-5MR	14	22.28	21.14	175	183
15-5MR	15	23.87	22.73	175	183
16-5MR	16	25.46	24.32	175	183
18-5MR	18	28.65	27.51	200	200
20-5MR	20	31.83	30.69	200	200
21-5MR	21	33.42	32.28	200	200
22-5MR	22	35.01	33.87	200	200
24-5MR	24	38.20	37.06	200	200
26-5MR	26	41.38	40.24	200	200
28-5MR	28	44.56	43.42	200	200
30-5MR	30	47.75	46.60	200	200
32-5MR	32	50.93	49.79	200	200
34-5MR	34	54.11	52.97	200	200
36-5MR	36	57.30	56.16	200	200
40-5MR	40	63.66	62.52	200	200
44-5MR	44	70.03	68.89	200	200
48-5MR	48	76.39	75.25	200	200
54-5MR	54	85.94	84.80	200	200
60-5MR	60	95.49	94.35	200	200
64-5MR	64	101.86	100.72	200	200
72-5MR	72	114.59	113.45	200	200

N.B. The GT® - 3MR GT® - 5MR bars are only manufactured in Aluminium suitable for hard anodising. Available till sold out.

"GATES"[®] POLY CHAIN[®]

GT2 BELTS

The **POLY CHAIN[®] GT2** synchronous belts represent the most recent development of the "GATES"[®] range and provide excellent performance on industrial drives with high torque and low speed. The belt's reverse surface and the teeth are made using a polyurethane mix and ensure special adhesion to the drive body. This particular type of polyurethane renders the belt resistant and virtually immune to abrasion and attack by chemical agents. The aramide strands give the belt extraordinary transmission capacity and excellent resistance to wear.

The belts have a very long useful working life and operate perfectly at temperatures lying between -54°C and + 85°C.

Both the belts and the pulleys are manufactured with the following pitches: 8mm - 8MGT and 14mm - 14 MGT.

Belt characteristics

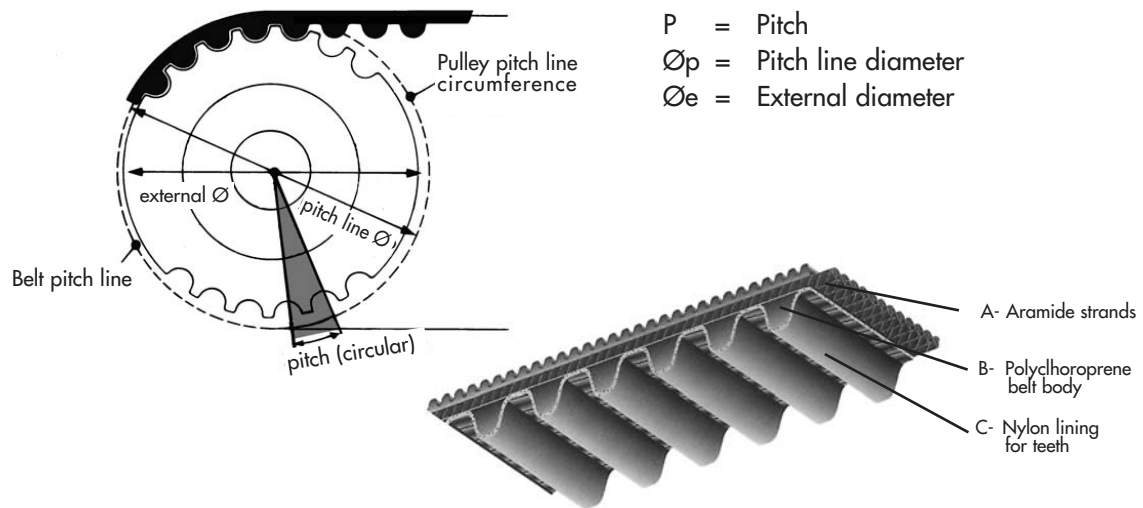

Belt identification

8MGT Pitch in mm.
 1280 Pitch line extension
 36 Belt width

} 8MGT - 1280 - 36

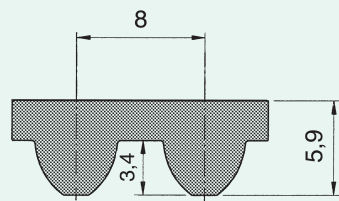

Type: 8MGT

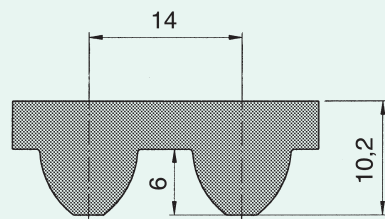

Type: 14MGT

"GATES"® POLY CHAIN® - GT2 BELTS

PITCH SELECTION FOR POLY CHAIN GT2 BELT

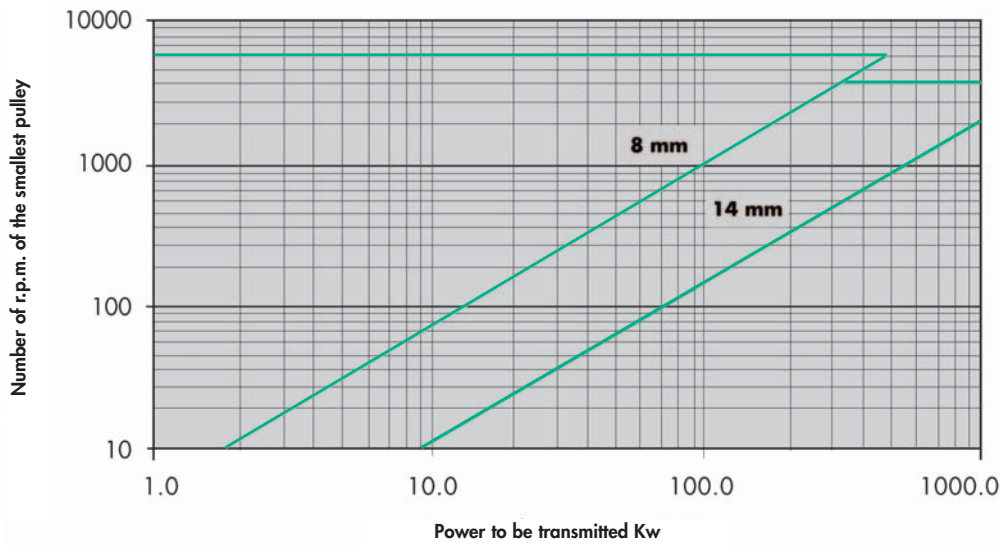

POLY CHAIN GT2 BELT WIDTHS

PITCH	8MGT	14MGT		
BELT WIDTHS mm.	12	20		
	21	37		
	36	68		
	62	90		
		125		

8MGT (8mm. pitch)

No. of Teeth	Pitch line length	Belt type
80	640	8MGT-640
95	720	8MGT-720
100	800	8MGT-800
112	896	8MGT-896
125	1000	8MGT-1000
140	1120	8MGT-1120
150	1200	8MGT-1200
160	1280	8MGT-1280
180	1440	8MGT-1440
200	1600	8MGT-1600
224	1792	8MGT-1792
250	2000	8MGT-2000
280	2240	8MGT-2240
300	2400	8MGT-2400
315	2520	8MGT-2520
355	2840	8MGT-2840
400	3200	8MGT-3200
450	3600	8MGT-3600
500	4000	8MGT-4000
560	4480	8MGT-4480

14MGT (14mm. pitch)

No. of Teeth	Pitch line length	Belt type
71	994	14MGT-994
80	1120	14MGT-1120
85	1190	14MGT-1190
90	1260	14MGT-1260
100	1400	14MGT-1400
112	1568	14MGT-1568
125	1750	14MGT-1750
135	1890	14MGT-1890
140	1960	14MGT-1960
150	2100	14MGT-2100
160	2240	14MGT-2240
170	2380	14MGT-2380
180	2520	14MGT-2520
190	2660	14MGT-2660
200	2800	14MGT-2800
224	3136	14MGT-3136
236	3304	14MGT-3304
250	3500	14MGT-3500
280	3920	14MGT-3920
315	4410	14MGT-4410

POLY CHAIN® GT® TAPER-LOCK® "PHOSPHATED" PULLEYS

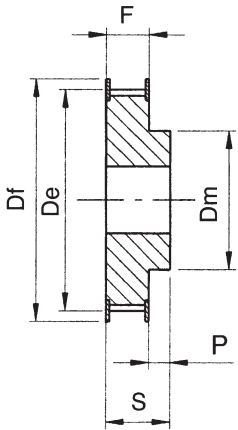

EXECUTION 1F

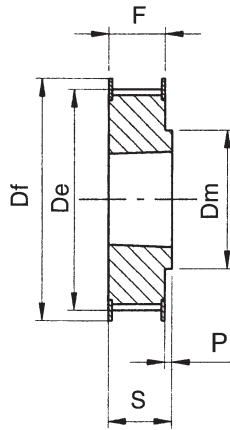

EXECUTION 2F

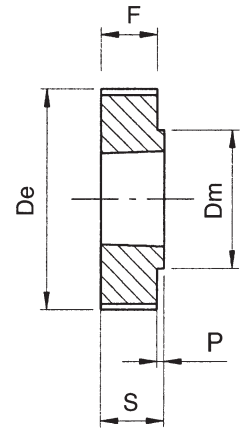

EXECUTION 3

POLY CHAIN GT 8M-12

CHARACTERISTICS	TYPE	No. of TEETH	EXEC.	BUSH	MAX. BORE	Dp PITCH LINE	De EXTERNAL	Df FLANGE	Dm HUB	Di	F	S	P	FLANGE No.	WEIGHT KG.	
STEEL	WITH FLANGE	8M-22S-12	22	1F	-	28	56.02	54.42	60	43	-	20	30	-	53	0.43
	TL 8M-25S-12	25	2F	1108	28	63.66	62.06	70	49	-	20	22	-	61	0.25	
	TL 8M-28S-12	28	2F	1108	28	71.30	69.70	75	56	-	20	22	-	79	0.37	
	TL 8M-30S-12	30	2F	1210	32	76.39	74.79	82.5	60	-	20	25	-	82	0.41	
	TL 8M-32S-12	32	2F	1610	42	81.49	79.89	87	66	-	20	25	-	76	0.37	
	TL 8M-34S-12	34	2F	1610	42	86.58	84.98	91	69	-	20	25	-	66	0.45	
	TL 8M-36S-12	36	2F	1610	42	91.67	90.07	97	76	-	20	25	-	68	0.59	
	TL 8M-38S-12	38	2F	1610	42	96.77	95.17	102	78	-	20	25	-	70	0.70	
	TL 8M-40S-12	40	2F	1610	42	101.86	100.26	106	85	-	20	25	-	77	0.82	
	TL 8M-45S-12	45	2F	2012	50	114.59	112.99	120	92	-	20	32	-	75	1.10	
	TL 8M-48S-12	48	2F	2012	50	122.23	120.63	128	103	-	20	32	-	78	1.42	
	TL 8M-50S-12	50	2F	2012	50	127.32	125.72	135	104	-	20	32	-	80	1.60	
	TL 8M-56S-12	56	2F	2012	50	142.60	141.00	150	104	-	20	32	-	85	2.10	
	TL 8M-60S-12	60	2F	2012	50	152.79	151.19	158	111	-	20	32	-	86	2.40	
	TL 8M-64S-12	64	2F	2012	50	162.97	161.37	168	111	-	20	32	-	90	2.70	
	WITHOUT FLANGE	TL 8M-75S-12	75	3	2012	50	190.99	189.39	-	111	-	20	32	-	-	3.70
TL 8M-80S-12	80	3	2012	50	203.72	202.12	-	111	-	20	32	-	-	4.40		
TL 8M-90S-12	90	3	2012	50	229.18	227.58	-	111	-	20	32	-	-	5.50		

POLY CHAIN® GT® TAPER-LOCK® "PHOSPHATED" PULLEYS

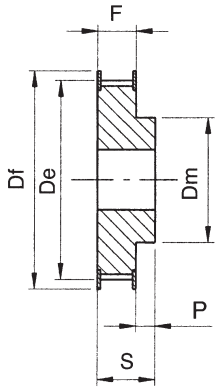

EXECUTION 1F

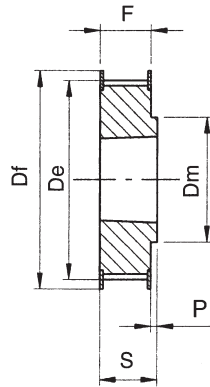

EXECUTION 2F

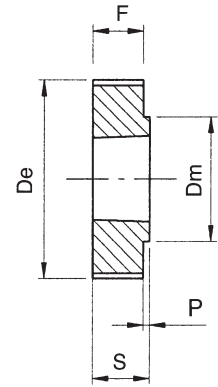

EXECUTION 3

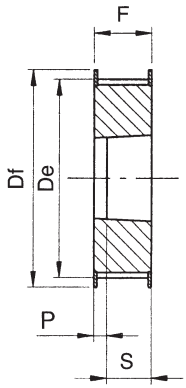

EXECUTION 4F

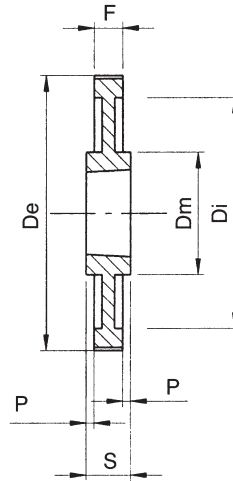

EXECUTION 11

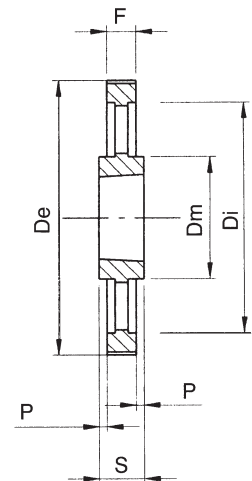

EXECUTION 13

POLY CHAIN GT 8M-21

CHARACTERISTICS	TYPE	No. of TEETH	EXEC.	BUSH	MAX. BORE	Dp PITCH LINE	De EXTERNAL	Df FLANGE	Dm HUB	Di	F	S	P	FLANGE No.	WEIGHT KG.	
STEEL	WITH FLANGE	8M-22S-21	22	1F	-	28	56.02	54.42	60	43	-	30	42	-	53	0.56
	TL 8M-25S-21	25	4F	1108	28	63.66	62.06	70	-	-	30	22	-	61	0.36	
	TL 8M-28S-21	28	4F	1210	32	71.30	69.70	75	-	-	30	25	-	79	0.41	
	TL 8M-30S-21	30	4F	1210	32	76.39	74.79	82.5	-	-	30	25	-	82	0.56	
	TL 8M-32S-21	32	4F	1610	42	81.49	79.89	87	-	-	30	25	-	76	0.52	
	TL 8M-34S-21	34	4F	1610	42	86.58	84.98	91	-	-	30	25	-	66	0.61	
	TL 8M-36S-21	36	4F	1610	42	91.67	90.07	97	-	-	30	25	-	68	0.70	
	TL 8M-38S-21	38	4F	1610	42	96.77	95.17	102	-	-	30	25	-	70	0.92	
	TL 8M-40S-21	40	4F	1610	42	101.86	100.26	106	-	-	30	25	-	77	1.06	
	TL 8M-45S-21	45	2F	2012	50	114.59	112.99	120	92	-	30	32	-	75	1.30	
	TL 8M-48S-21	48	2F	2012	50	122.23	120.63	128	103	-	30	32	-	78	1.60	
	TL 8M-50S-21	50	2F	2012	50	127.32	125.72	135	104	-	30	32	-	80	1.83	
	TL 8M-56S-21	56	2F	2012	50	142.60	141.00	150	104	-	30	32	-	85	2.40	
	TL 8M-60S-21	60	2F	2517	60	152.79	151.19	158	124	-	30	45	-	86	3.20	
	TL 8M-64S-21	64	2F	2517	60	162.97	161.37	168	124	-	30	45	-	90	3.80	
CAST IRON	WITHOUT FLANGE	TL 8M-75S-21	75	3	2517	60	190.99	189.39	-	124	-	30	45	-	-	6.20
	TL 8M-80S-21	80	3	2517	60	203.72	202.12	-	124	-	30	45	-	-	6.00	
	TL 8M-90S-21	90	11	2517	60	229.18	227.58	-	124	198	30	45	7.5	-	5.40	
	TL 8M-112S-21	112	11	2517	60	285.21	283.61	-	124	253	30	45	7.5	-	7.40	
	TL 8M-140S-21	140	13	3020	75	356.51	354.91	-	150	324	30	51	10.5	-	9.00	

POLY CHAIN® GT® TAPER-LOCK® "PHOSPHATED" PULLEYS

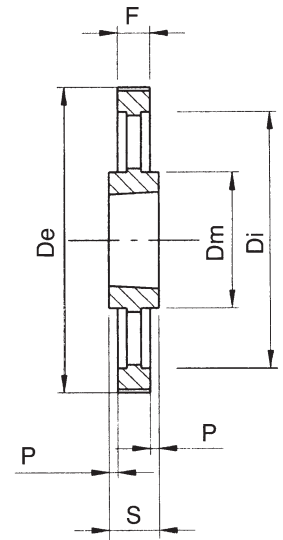
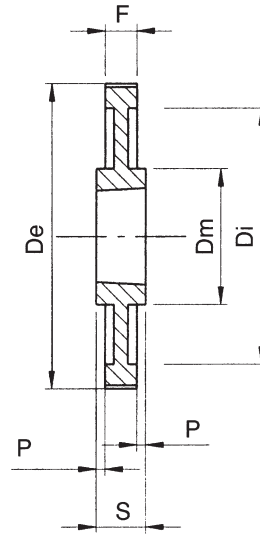
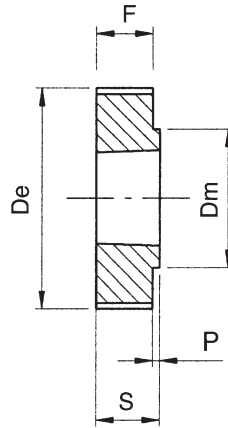
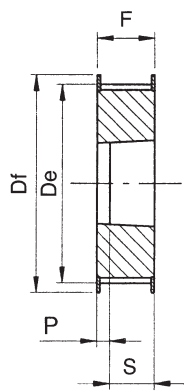
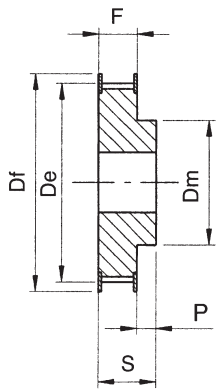

EXECUTION 1F

EXECUTION 4F

EXECUTION 3

EXECUTION 11

EXECUTION 13

POLY CHAIN GT 8M-36

CHARACTERISTICS	TYPE	No. of TEETH	EXEC.	BUSH	MAX. BORE	Dp PITCH LINE	De EXTERNAL	Df FLANGE	Dm HUB	Di	F	S	P	FLANGE No.	WEIGHT KG.	
STEEL	WITH FLANGE	8M-25S-36	25	1F	-	32	63.66	62.06	70	49	-	45	55	61	1.04	
		TL 8M-28S-36	28	4F	1210	32	71.30	69.70	75	-	-	45	25	20	79	0.64
		TL 8M-30S-36	30	4F	1610	42	76.39	74.79	82.5	-	-	45	25	20	82	0.59
		TL 8M-32S-36	32	4F	1610	42	81.49	79.89	87	-	-	45	25	20	76	0.79
		TL 8M-34S-36	34	4F	1610	42	86.58	84.98	91	-	-	45	25	20	66	0.93
		TL 8M-36S-36	36	4F	1610	42	91.67	90.07	97	-	-	45	25	20	68	1.15
		TL 8M-38S-36	38	4F	1610	42	96.77	95.17	102	-	-	45	25	20	70	1.39
		TL 8M-40S-36	40	4F	2012	50	101.86	100.26	106	-	-	45	32	13	77	1.34
		TL 8M-45S-36	45	4F	2012	50	114.59	112.99	120	-	-	45	32	13	75	1.87
		TL 8M-48S-36	48	4F	2012	50	122.23	120.63	128	-	-	45	32	13	78	2.20
		TL 8M-50S-36	50	4F	2012	50	127.32	125.72	135	-	-	45	32	13	80	2.70
		TL 8M-56S-36	56	4F	2517	60	142.60	141.00	150	-	-	45	45	-	85	3.00
		TL 8M-60S-36	60	4F	2517	60	152.79	151.19	158	-	-	45	45	-	86	3.80
		TL 8M-64S-36	64	4F	2517	60	162.97	161.37	168	-	-	45	45	-	90	4.50
CAST IRON	WITHOUT FLANGE	TL 8M-75S-36	75	3	3020	75	190.99	189.39	-	150	-	45	51	6	6.20	
		TL 8M-80S-36	80	3	3020	75	203.72	202.12	-	150	-	45	51	6	7.40	
		TL 8M-90S-36	90	11	3020	75	229.18	227.58	-	150	197	45	51	3	7.20	
		TL 8M-112S-36	112	11	3020	75	285.21	283.61	-	150	253	45	51	3	-	10.40
		TL 8M-140S-36	140	13	3020	75	356.51	354.91	-	150	324	45	51	3	-	12.70
		TL 8M-168S-36	168	13	3525	100	427.81	426.21	-	198	396	45	65	10	-	21.50
		TL 8M-192S-36	192	13	3525	100	488.92	487.32	-	198	457	45	65	10	-	27.00

POLY CHAIN® GT® TAPER-LOCK® "PHOSPHATED" PULLEYS

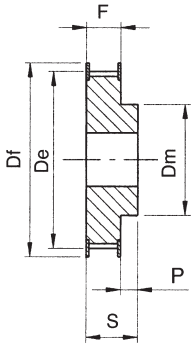

EXECUTION 1F

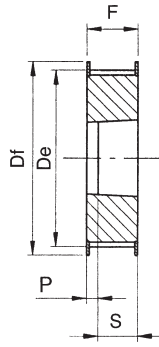

EXECUTION 4F

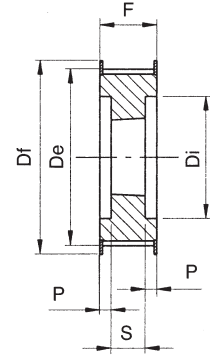

EXECUTION 7F

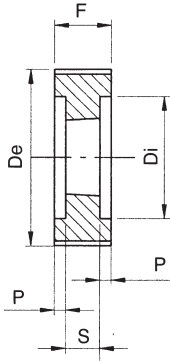

EXECUTION 6

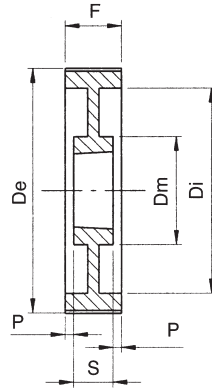

EXECUTION 8

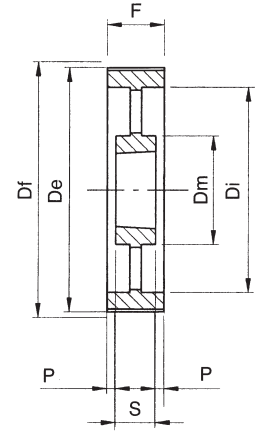

EXECUTION 10

POLY CHAIN GT 8M-62

CHARACTERISTICS	TYPE	No. of TEETH	EXEC.	BUSH	MAX. BORE	Dp PITCH LINE	De EXTERNAL	Df FLANGE	Dm HUB	Di	F	S	P	FLANGE No.	WEIGHT KG.		
STEEL	WITH FLANGE	8M-30S-62	30	1F	-	42	76.39	74.79	82.5	63	-	72	84	-	82	2.40	
		8M-32S-62	32	1F	-	50	81.49	79.89	87	68	-	72	84	-	76	2.80	
		8M-34S-62	34	1F	-	55	86.58	84.98	91	69	-	72	84	-	66	3.00	
		8M-36S-62	36	1F	-	60	91.67	90.07	97	76	-	72	84	-	68	3.40	
		8M-38S-62	38	1F	-	60	96.77	95.17	102	78	-	72	84	-	70	3.80	
	TL 8M-40S-62	40	4F	2012	50	101.86	100.26	106	-	-	72	32	-	77	2.06		
	TL 8M-45S-62	45	4F	2012	50	114.59	112.99	120	-	-	72	32	-	75	3.00		
	TL 8M-48S-62	48	4F	2517	60	122.23	120.63	128	-	-	72	45	-	78	2.90		
	TL 8M-50S-62	50	4F	2517	60	127.32	125.72	135	-	-	72	45	-	80	3.25		
	TL 8M-56S-62	56	7F	2517	60	142.60	141.00	150	-	111	72	45	13.5	85	3.90		
	TL 8M-60S-62	60	7F	2517	60	152.79	151.19	158	-	121	72	45	13.5	86	4.70		
	TL 8M-64S-62	64	7F	2517	60	162.97	161.37	168	-	131	72	45	13.5	90	5.60		
	CAST IRON	WITHOUT FLANGE	TL 8M-75S-62	75	6	3020	75	190.99	189.39	-	-	159	72	51	10.5	-	7.50
			TL 8M-80S-62	80	6	3020	75	203.72	202.12	-	-	172	72	51	10.5	-	9.20
TL 8M-90S-62			90	6	3020	75	229.18	227.58	-	-	197	72	51	10.5	-	7.70	
TL 8M-112S-62			112	8	3020	75	285.21	283.61	-	198	253	72	51	10.5	-	12.10	
TL 8M-140S-62			140	8	3525	100	356.51	354.91	-	150	324	72	65	3.5	-	22.70	
TL 8M-168S-62	168	10	3525	100	427.81	426.21	-	198	396	72	65	3.5	-	26.80			
TL 8M-192S-62	192	10	3525	100	488.92	487.32	-	198	457	72	65	3.5	-	34.20			

POLY CHAIN® GT® TAPER-LOCK® "PHOSPHATED" PULLEYS

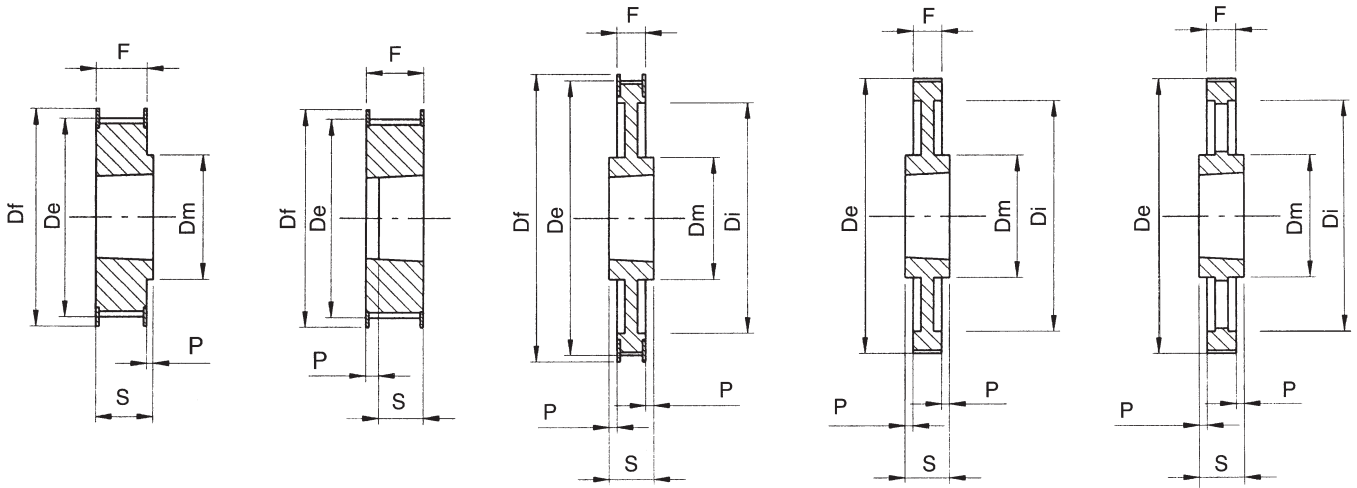

EXECUTION 2F

EXECUTION 4F

EXECUTION 12F

EXECUTION 11

EXECUTION 13

POLY CHAIN GT 14M-20

CHARACTERISTICS	TYPE	No. of TEETH	EXEC.	BUSH	MAX. BORE	Dp PITCH LINE	De EXTERNAL	Df FLANGE	Dm HUB	Di	F	S	P	FLANGE No.	WEIGHT KG.	
STEEL	WITH FLANGE	TL 14M-28S-20	28	4F	2012	50	124.78	121.98	128	-	-	33	32	1	153	1.66
		TL 14M-30S-20	30	4F	2012	50	133.69	130.89	138	-	-	33	32	1	154	2.20
		TL 14M-32S-20	32	4F	2012	50	142.60	139.80	154	-	-	33	32	1	160	3.20
		TL 14M-34S-20	34	2F	2517	60	151.52	148.72	160	117	-	33	45	-	171	3.00
		TL 14M-36S-20	36	2F	2517	60	160.43	157.63	168	117	-	33	45	-	168	3.60
		TL 14M-38S-20	38	2F	2517	60	169.34	166.54	183	117	-	33	45	-	172	4.00
		TL 14M-40S-20	40	2F	2517	60	178.25	175.45	188	117	-	33	45	-	174	4.70
		TL 14M-44S-20	44	2F	3020	75	196.08	193.28	211	144	-	33	51	-	175	5.60
		TL 14M-48S-20	48	2F	3020	75	213.90	211.11	226	144	-	33	51	-	180	6.80
		TL 14M-50S-20	50	2F	3020	75	222.82	220.02	240	144	-	33	51	-	169	7.70
TL 14M-56S-20	56	12F	3020	75	249.55	246.76	256	144	207	33	51	9	182	7.70		
CAST IRON	WITHOUT FLANGE	TL 14M-60S-20	60	11	3020	75	267.38	264.58	-	159	224	33	51	9	-	8.50
		TL 14M-64S-20	64	11	3020	75	285.21	282.41	-	159	242	33	51	9	-	10.20
		TL 14M-72S-20	72	11	3020	75	320.86	318.06	-	159	278	33	51	9	-	11.50
		TL 14M-80S-20	80	11	3020	75	356.51	353.71	-	159	314	33	51	9	-	13.50
		TL 14M-90S-20	90	13	3020	75	401.07	398.27	-	159	360	33	51	9	-	14.20
		TL 14M-112S-20	112	13	3020	75	499.11	496.31	-	159	456	33	51	9	-	18.10
		TL 14M-140S-20	140	13	3020	75	623.89	621.09	-	159	581	33	51	9	-	22.90

POLY CHAIN® GT® TAPER-LOCK® "PHOSPHATED" PULLEYS

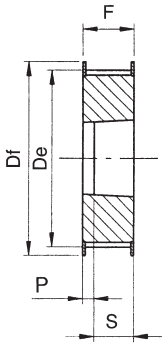

EXECUTION 4F

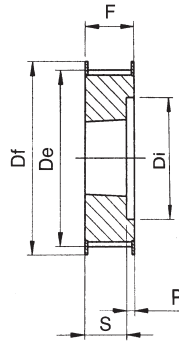

EXECUTION 5F

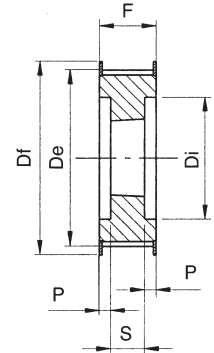

EXECUTION 7F

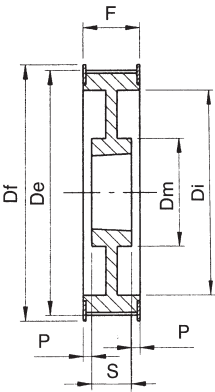

EXECUTION 9F

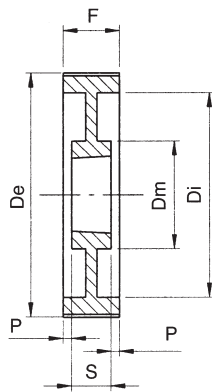

EXECUTION 8

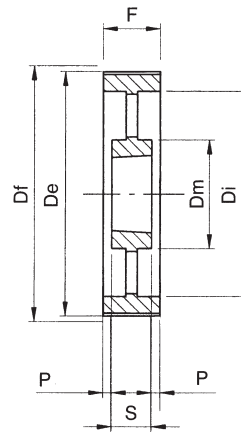

EXECUTION 10

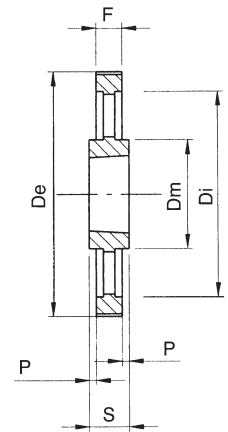

EXECUTION 13

POLY CHAIN GT 14M-37

CHARACTERISTICS	TYPE	No. of TEETH	EXEC.	BUSH	MAX. BORE	Dp PITCH LINE	De EXTERNAL	Df FLANGE	Dm HUB	Di	F	S	P	FLANGE No.	WEIGHT KG.	
STEEL	WITH FLANGE	TL 14M-28S-37	28	5F	2012	50	124.78	121.98	128	-	88	51	32	19	153	2.20
		TL 14M-30S-37	30	7F	2517	60	133.69	130.89	138	-	98	51	45	3	154	2.50
		TL 14M-32S-37	32	7F	2517	60	142.60	139.80	154	-	100	51	45	3	160	3.00
		TL 14M-34S-37	34	7F	2517	60	151.52	148.72	160	-	109	51	45	3	171	3.80
		TL 14M-36S-37	36	5F	2517	60	160.43	157.63	168	-	117	51	45	6	168	4.30
		TL 14M-38S-37	38	5F	2517	60	169.34	166.54	183	-	126	51	45	6	172	5.10
		TL 14M-40S-37	40	5F	2517	60	178.25	175.45	188	-	135	51	45	6	174	6.00
		TL 14M-44S-37	44	4F	3020	75	196.08	193.28	211	-	-	51	51	-	175	7.00
		TL 14M-48S-37	48	4F	3020	75	213.90	211.11	226	-	-	51	51	-	180	9.00
		TL 14M-50S-37	50	4F	3020	75	222.82	220.02	240	-	-	51	51	-	169	10.00
TL 14M-56S-37	56	9F	3020	75	249.55	246.76	256	144	207	51	51	-	182	9.20		
CAST IRON	WITHOUT FLANGE	TL 14M-60S-37	60	8	3020	75	267.38	264.58	-	159	224	51	51	-	-	10.20
		TL 14M-64S-37	64	8	3020	75	285.21	282.41	-	159	242	51	51	-	-	12.20
		TL 14M-72S-37	72	8	3020	75	320.86	318.06	-	159	278	51	51	-	-	13.40
		TL 14M-80S-37	80	8	3020	75	356.51	353.71	-	159	314	51	51	-	-	16.10
		TL 14M-90S-37	90	10	3020	75	401.07	398.27	-	159	360	51	51	-	-	17.20
		TL 14M-112S-37	112	10	3020	75	499.11	496.31	-	159	456	51	51	-	-	23.00
		TL 14M-140S-37	140	13	3525	100	623.89	621.09	-	206	581	51	65	7	-	41.00
		TL 14M-168S-37	168	13	3525	100	748.66	745.87	-	206	706	51	65	7	-	51.50
		TL 14M-192S-37	192	13	4030	115	855.61	852.82	-	215	812	51	76	12.5	-	60.00

POLY CHAIN® GT® TAPER-LOCK® "PHOSPHATED" PULLEYS

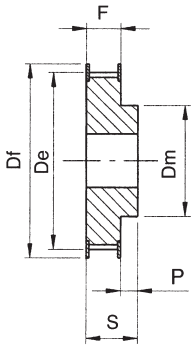

EXECUTION 1F

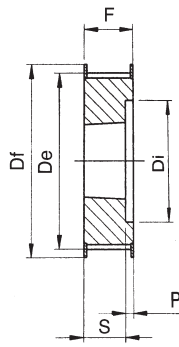

EXECUTION 5F

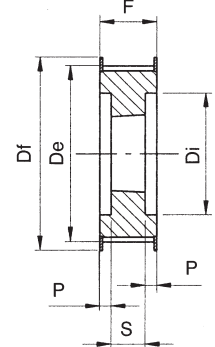

EXECUTION 7F

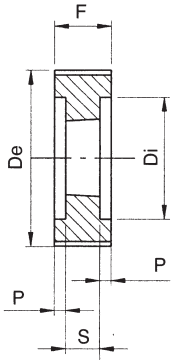

EXECUTION 6

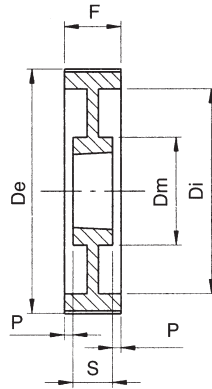

EXECUTION 8

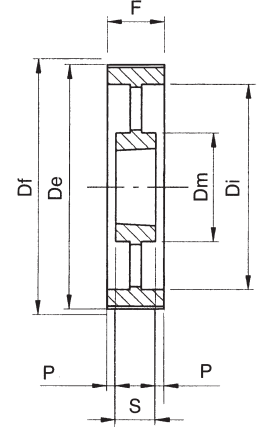

EXECUTION 10

POLY CHAIN GT 14M-68

CHARACTERISTICS	TYPE	No. of TEETH	EXEC.	BUSH	MAX. BORE	Dp PITCH LINE	De EXTERNAL	Df FLANGE	Dm HUB	Di	F	S	P	FLANGE No.	WEIGHT KG.	
STEEL	WITH FLANGE	14M-34S-68	34	1F	-	100	151.52	148.72	160	132	-	84	104	-	171	10.50
		14M-36S-68	36	1F	-	100	160.43	157.63	168	131	-	84	104	-	168	11.70
		14M-38S-68	38	1F	-	115	169.34	166.54	183	141	-	84	104	-	172	13.40
		14M-40S-68	40	1F	-	125	178.25	175.45	188	156	-	84	104	-	174	15.40
		TL 14M-44S-68	44	7F	3020	75	196.08	193.28	211	-	153	84	51	16.5	175	9.20
		TL 14M-48S-68	48	5F	3020	75	213.90	211.11	226	-	171	84	51	33	180	11.30
		TL 14M-50S-68	50	7F	3525	100	222.82	220.02	240	-	180	84	65	9.5	169	15.50
		TL 14M-56S-68	56	7F	3525	100	249.55	246.76	256	-	207	84	65	9.5	182	16.80
	TL 14M-60S-68	60	6	3525	100	267.38	264.58	-	-	224	84	65	9.5	-	20.40	
CAST IRON	WITHOUT FLANGE	TL 14M-64S-68	64	6	3525	100	285.21	282.41	-	-	242	84	65	9.5	-	23.60
		TL 14M-72S-68	72	8	3525	100	320.86	318.06	-	178	278	84	65	9.5	-	20.30
		TL 14M-80S-68	80	8	3525	100	356.51	353.71	-	178	314	84	65	9.5	-	21.30
		TL 14M-90S-68	90	10	3525	100	401.07	398.27	-	178	360	84	65	9.5	-	24.40
		TL 14M-112S-68	112	10	3525	100	499.11	496.31	-	178	456	84	65	9.5	-	32.70
		TL 14M-140S-68	140	10	3525	100	623.89	621.09	-	206	581	84	65	9.5	-	55.00
		TL 14M-168S-68	168	10	3525	100	748.66	745.87	-	206	706	84	65	9.5	-	71.00
		TL 14M-192S-68	192	10	4030	115	855.61	852.82	-	215	812	84	76	4	-	80.50

POLY CHAIN® GT® TAPER-LOCK® "PHOSPHATED" PULLEYS

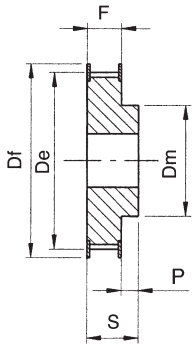

EXECUTION 1F

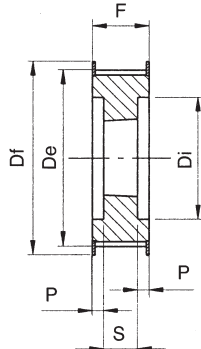

EXECUTION 7F

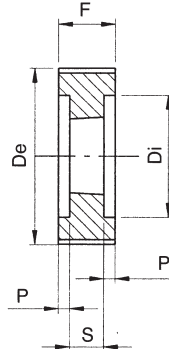

EXECUTION 6

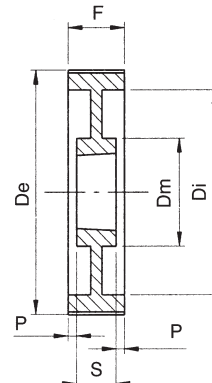

EXECUTION 8

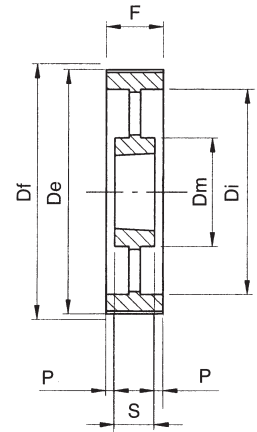

EXECUTION 10

POLY CHAIN GT 14M-90

CHARACTERISTICS		TYPE	No. of TEETH	EXEC.	BUSH	MAX. BORE	Dp PITCH LINE	De EXTERNAL	Df FLANGE	Dm HUB	Di	F	S	P	FLANGE No.	WEIGHT KG.
STEEL	WITH FLANGE	14M-36S-90	36	1F	-	110	160.43	157.63	168	131	-	106	136	-	168	14.50
		14M-38S-90	38	1F	-	115	169.34	166.54	183	141	-	106	136	-	172	17.50
		14M-40S-90	40	1F	-	125	178.25	175.45	188	156	-	106	136	-	174	19.10
		14M-44S-90	44	1F	-	140	196.08	193.28	211	169	-	106	136	-	175	23.90
		TL 14M-48S-90	48	7F	3525	100	213.90	211.11	226	-	171	106	66	20	180	12.70
		TL 14M-50S-90	50	7F	3525	100	222.82	220.02	240	-	180	106	66	20	169	14.50
		TL 14M-56S-90	56	7F	3525	100	249.55	246.76	256	-	207	106	66	20	182	19.00
		TL 14M-60S-90	60	6	3525	100	267.38	264.58	-	-	224	106	66	20	-	22.50
CAST IRON	WITHOUT FLANGE	TL 14M-64S-90	64	6	3525	100	285.21	282.41	-	-	242	106	66	20	-	24.00
		TL 14M-72S-90	72	8	3525	100	320.86	318.06	-	178	278	106	66	20	-	22.60
		TL 14M-80S-90	80	8	4030	115	356.51	353.71	-	215	314	106	76	15	-	27.00
		TL 14M-90S-90	90	8	4030	115	401.07	398.27	-	215	360	106	76	15	-	34.10
		TL 14M-112S-90	112	10	4535	125	499.11	496.31	-	215	456	106	90	8	-	46.00
		TL 14M-140S-90	140	10	4535	125	623.89	621.09	-	215	581	106	90	8	-	61.00
		TL 14M-168S-90	168	10	5040	130	748.66	745.87	-	267	706	106	102	2	-	90.00
		TL 14M-192S-90	192	10	5040	130	855.61	852.82	-	267	812	106	102	2	-	108.50

POLY CHAIN® GT® TAPER-LOCK® "PHOSPHATED" PULLEYS

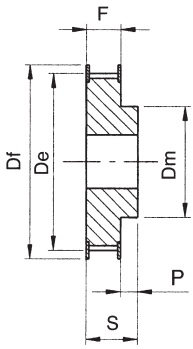

EXECUTION 1F

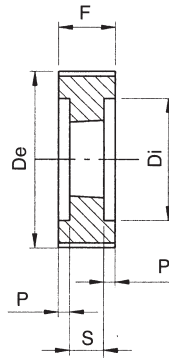

EXECUTION 6

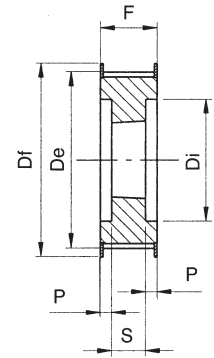

EXECUTION 7F

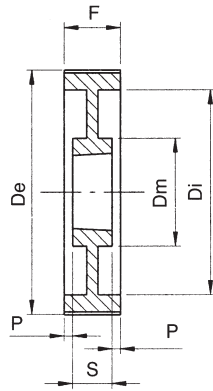

EXECUTION 8

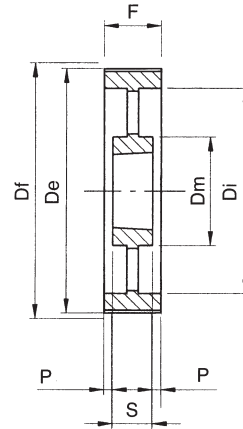

EXECUTION 10

POLY CHAIN GT 14M-125

CHARACTERISTICS		TYPE	No. of TEETH	EXEC.	BUSH	MAX. BORE	Dp PITCH LINE	De EXTERNAL	Df FLANGE	Dm HUB	Di	F	S	P	FLANGE No.	WEIGHT KG.
STEEL	WITH FLANGE	14M-38S-125	38	1F	-	115	169.34	166.54	183	141	-	141	161	-	172	20.30
		14M-40S-125	40	1F	-	125	178.25	175.45	188	156	-	141	161	-	174	23.00
		14M-44S-125	44	1F	-	140	196.08	193.28	211	169	-	141	161	-	175	28.80
		14M-48S-125	48	1F	-	160	213.90	211.11	226	185	-	141	161	-	180	34.60
		TL 14M-50S-125	50	7F	3525	100	222.82	220.02	240	-	180	141	65	38	169	16.80
		TL 14M-56S-125	56	7F	3525	100	249.55	246.76	256	-	207	141	65	38	182	21.60
CAST IRON	WITHOUT FLANGE	TL 14M-60S-125	60	6	4030	115	267.38	264.58	-	-	224	141	76	32.5	-	25.60
		TL 14M-64S-125	64	6	4030	115	285.21	282.41	-	-	242	141	76	32.5	-	29.70
		TL 14M-72S-125	72	8	4030	115	320.86	318.06	-	215	278	141	76	32.5	-	30.00
		TL 14M-80S-125	80	8	4030	125	356.51	353.71	-	215	314	141	76	32.5	-	33.40
		TL 14M-90S-125	90	8	4030	115	401.07	398.27	-	215	360	141	76	32.5	-	39.40
		TL 14M-112S-125	112	10	4535	125	499.11	496.31	-	215	456	141	89	26	-	56.00
		TL 14M-140S-125	140	10	4535	125	623.89	621.09	-	215	581	141	89	26	-	73.00
		TL 14M-168S-125	168	10	5040	125	748.66	745.87	-	267	706	141	102	19.5	-	101.00
		TL 14M-192S-125	192	10	5040	125	855.61	852.82	-	267	802	141	102	19.5	-	121.50

"GATES" licence N. 0.203.235

POLY CHAIN® GT® BARS

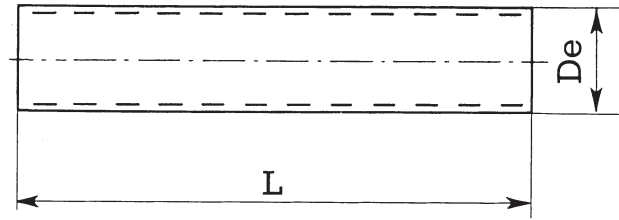

POLY CHAIN GT® 8M (8mm. pitch)

CODE REFERENCE	Dp	De	L	SUITABLE FLANGE
8M-22	56.02	54.42	180	58
8M-25	63.66	62.06	180	61
8M-28	71.30	69.70	180	62
8M-30	76.39	74.79	180	82
8M-32	81.49	79.89	180	65
8M-34	86.58	84.98	180	66
8M-36	91.67	90.07	180	68
8M-38	96.77	95.17	180	70
8M-40	101.86	100.26	200	71
8M-45	114.59	112.99	200	75
8M-48	122.23	120.63	200	78
8M-50	127.32	125.72	200	80
8M-56	142.60	141.00	200	85
8M-60	152.79	151.19	200	86
8M-64	162.97	161.37	200	90
8M-75	190.99	189.39	200	100

POLY CHAIN GT® 14M (14mm. pitch)

CODE REFERENCE	Dp	De	L	SUITABLE FLANGE
14M-28	124.78	121.98	200	153
14M-30	133.69	130.89	200	154
14M-32	142.60	139.80	200	157
14M-34	151.52	148.72	200	158
14M-36	160.43	157.63	200	168
14M-38	169.34	166.54	200	161
14M-40	178.25	175.45	200	162
14M-45	196.08	193.28	200	165
14M-48	213.90	211.11	200	167

"GATES" licence No. 0.203.236

MATERIAL: STEEL C 40 UNI 7845

"T" METRIC PULLEYS, BELTS AND BARS

Dimensional features

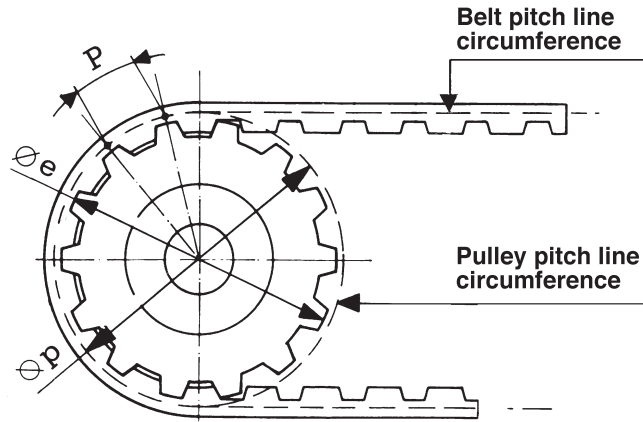

SYMBOLS:

P	=	Pitch
Z	=	No. of Teeth
Øp	=	Pulley pitch line
Øe	=	External diameter
Lp	=	Pulley width
Lc	=	Belt width
Lpc	=	Belt pitch line length

12 T10 440	{	12 = Belt width in mm.
		T10 = Tooth pitch in mm.
		440 = Pitch line length in mm.

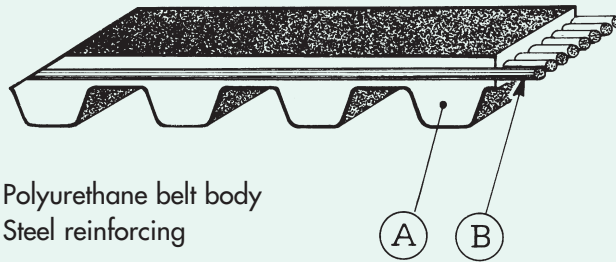

- A) Polyurethane belt body
- B) Steel reinforcing

STANDARD WIDTH FOR BELTS AND SHEARING TOLERANCES

belt pitch	belt width (mm)	width tolerance (mm)
T 2.5 (2.5 mm)	6	± 0.3
T 5 (5 mm)	10	± 0.5
	16	
	25	
T 10 (10 mm)	16	± 0.5
	25	
	32	
	50	

" T " METRIC " M E C T R O L "® P O L Y U R E T H A N E B E L T S

T 2.5 (2.5mm pitch)

Belt Type	No. of teeth	Pitch line length
T2.5-120	48	120.0
T2.5-145	58	145.0
T2.5-160	64	160.0
T2.5-177	71	177.5
T2.5-200	80	200.0
T2.5-230	92	230.0
T2.5-245	98	245.0
T2.5-265	106	265.0
T2.5-285	114	285.0
T2.5-305	122	305.0
T2.5-317	127	317.5
T2.5-330	132	330.0
T2.5-380	152	380.0
T2.5-420	168	420.0
T2.5-480	192	480.0
T2.5-500	200	500.0
T2.5-600	240	600.0
T2.5-620	248	620.0
T2.5-650	260	650.0
T2.5-780	312	780.0
T2.5-915	366	915.0
T2.5-950	380	950.0

T 5 (5mm pitch)

Belt Type	No. of teeth	Pitch line length
T5-165	33	165.0
T5-185	37	185.0
T5-200	40	200.0
T5-215	43	215.0
T5-220	44	220.0
T5-225	45	225.0
T5-245	49	245.0
T5-255	51	255.0
T5-260	52	260.0
T5-270	54	270.0
T5-280	56	280.0
T5-295	59	295.0
T5-305	61	305.0
T5-330	66	330.0
T5-340	68	340.0
T5-350	70	350.0
T5-355	71	355.0
T5-365	73	365.0
T5-390	78	390.0
T5-400	80	400.0
T5-410	82	410.0
T5-420	84	420.0
T5-455	91	455.0
T5-480	96	480.0
T5-500	100	500.0
T5-510	102	510.0
T5-525	105	525.0
T5-545	109	545.0
T5-550	110	550.0
T5-560	112	560.0
T5-575	115	575.0
T5-610	122	610.0
T5-620	124	620.0
T5-630	126	630.0
T5-640	128	640.0
T5-650	130	650.0
T5-660	132	660.0
T5-690	138	690.0
T5-700	140	700.0
T5-720	144	720.0
T5-750	150	750.0
T5-780	156	780.0
T5-815	163	815.0
T5-840	168	840.0
T5-900	180	900.0
T5-990	198	990.0
T5-1075	215	1075.0
T5-1100	220	1100.0
T5-1215	243	1215.0
T5-1315	263	1315.0
T5-1380	276	1386.0

T 10 (10mm pitch)

Belt Type	No. of teeth	Pitch line length
T10-260	26	260
T10-370	37	370
T10-400	40	400
T10-410	41	410
T10-440	44	440
T10-500	50	500
T10-530	53	530
T10-560	56	560
T10-610	61	610
T10-630	63	630
T10-660	66	660
T10-690	69	690
T10-700	70	700
T10-720	72	720
T10-750	75	750
T10-780	78	780
T10-810	81	810
T10-840	84	840
T10-880	88	880
T10-920	92	920
T10-960	96	960
T10-970	97	970
T10-980	98	980
T10-1010	101	1010
T10-1080	108	1080
T10-1140	114	1140
T10-1150	115	1150
T10-1210	121	1210
T10-1240	124	1240
T10-1250	125	1250
T10-1300	130	1300
T10-1320	132	1320
T10-1350	135	1350
T10-1390	139	1390
T10-1400	140	1400
T10-1420	142	1420
T10-1450	145	1450
T10-1460	146	1460
T10-1500	150	1500
T10-1560	156	1560
T10-1610	161	1610
T10-1750	175	1750
T10-1780	178	1780
T10-1880	188	1880
T10-1960	196	1960
T10-2250	225	2250

PITCH SELECTION FOR "T" BELT

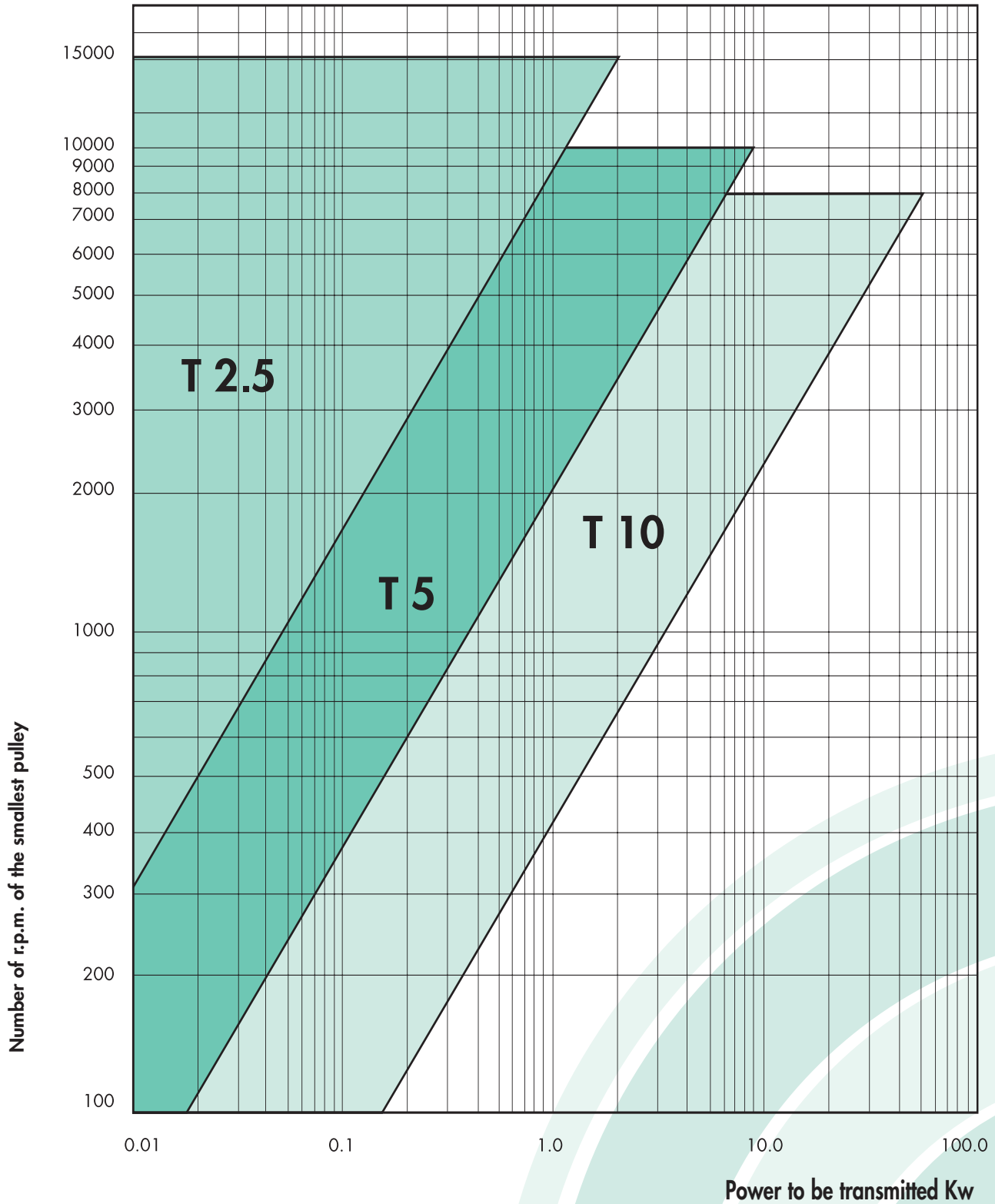

" T " P U L L E Y S

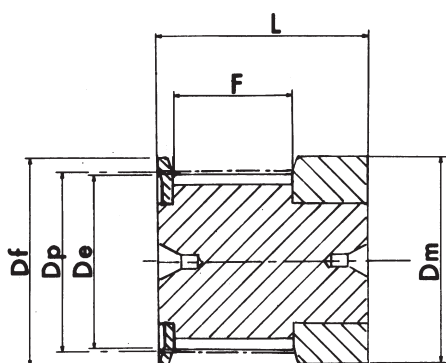

EXECUTION 0F

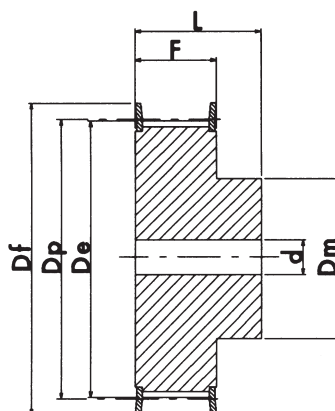

EXECUTION 1F

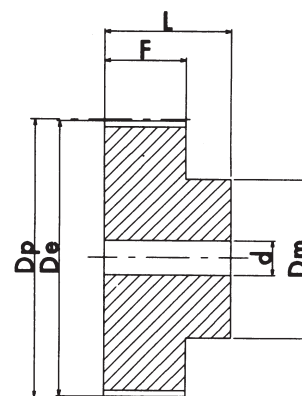

EXECUTION 2

How to identify a pulley – Example: 31 T10 25

Pulley width (mm) 31

Pulley pitch (mm) T10

No. of teeth on pulley 25

material: ALUMINIUM

T20 pitch pulleys and bars are manufactured on request.

T 2.5 (2.5 mm pitch) DESIGNED FOR 6 mm WIDE BELTS

ALUMINIUM

DESCRIPTION	EXEC.	No. of TEETH	Dp	De	Df	Dm	F	L	d	FLANGE No.
16 T2.5 12	0F	12	9.60	9.00	13.0	13	9	16	-	501
16 T2.5 14	0F	14	11.20	10.60	15.0	15	9	16	-	502
16 T2.5 15	0F	15	12.00	11.40	15.0	15	9	16	-	502
16 T2.5 16	0F	16	12.80	12.20	16.0	16	9	16	-	503
16 T2.5 16	1F	18	14.40	13.80	17.5	10	10	16	-	504
16 T2.5 19	1F	19	15.20	14.60	20.0	10	10	16	-	505
16 T2.5 20	1F	20	16.00	15.40	20.0	11	10	16	-	505
16 T2.5 22	1F	22	17.60	17.00	22.0	11	10	16	-	512
16 T2.5 24	1F	24	19.15	18.55	22.0	12	10	16	4	512
16 T2.5 25	1F	25	19.95	19.35	25.0	13	10	16	4	506
16 T2.5 26	1F	26	20.75	20.15	26.0	14	10	16	4	507
16 T2.5 28	1F	28	22.35	21.75	26.0	14	10	16	4	507
16 T2.5 30	1F	30	23.95	23.35	26.0	16	10	16	6	508
16 T2.5 32	1F	32	25.55	24.95	32.0	16	10	16	6	509
16 T2.5 36	1F	36	28.75	28.10	36.0	20	10	16	6	510
16 T2.5 40	1F	40	31.90	31.30	38.0	22	10	16	6	511
16 T2.5 44	2	44	35.10	34.50	-	24	10	16	6	-
16 T2.5 48	2	48	38.30	37.70	-	26	10	16	6	-
16 T2.5 60	2	60	47.85	47.25	-	34	10	16	8	-

" T " P U L L E Y S

T 5 (5 mm pitch) DESIGNED FOR 10 mm WIDE BELTS

ALUMINIUM	DESCRIPTION	EXEC.	No. of TEETH	Dp	De	Df	Dm	F	L	d	FLANGE No.
	21 T5 10	1F	10	15.92	15.05	19.5	8	15	21	-	3
21 T5 12	1F	12	19.10	18.25	23.0	11	15	21	-	1	
21 T5 14	1F	14	22.29	21.45	25.0	13	15	21	-	2	
21 T5 15	1F	15	23.88	23.05	28.0	16	15	21	6	4	
21 T5 16	1F	16	25.47	24.60	32.0	18	15	21	6	5	
21 T5 18	1F	18	28.65	27.80	32.0	20	15	21	6	6	
21 T5 19	1F	19	30.25	29.40	36.0	22	15	21	6	8	
21 T5 20	1F	20	31.83	31.00	36.0	23	15	21	6	8	
21 T5 22	1F	22	35.02	34.15	38.0	24	15	21	6	9	
21 T5 24	1F	24	38.21	37.40	42.0	26	15	21	6	13	
21 T5 25	1F	25	39.80	38.95	44.0	26	15	21	6	12	
21 T5 26	1F	26	41.39	40.60	44.0	26	15	21	6	12	
21 T5 27	1F	27	42.98	42.20	48.0	30	15	21	8	11	
21 T5 28	1F	28	44.58	43.75	48.0	32	15	21	8	11	
21 T5 30	1F	30	47.76	46.95	51.0	34	15	21	8	16	
21 T5 32	1F	32	50.94	50.10	54.0	38	15	21	8	18	
21 T5 36	1F	36	57.31	56.45	64.0	38	15	21	8	23	
21 T5 40	1F	40	63.66	62.85	66.5	40	15	21	8	24	
21 T5 42	1F	42	66.86	66.00	70.0	40	15	21	8	26	
21 T5 44	2	44	70.05	69.20	-	45	15	21	8	-	
21 T5 48	2	48	76.42	75.55	-	50	15	21	8	-	
21 T5 60	2	60	95.52	94.65	-	65	15	21	8	-	

T 5 (5 mm pitch) DESIGNED FOR 16 mm WIDE BELTS

ALUMINIUM	DESCRIPTION	EXEC.	No. of TEETH	Dp	De	Df	Dm	F	L	d	FLANGE No.
	27 T5 10	1F	10	15.92	15.05	19.5	8	21	27	-	3
27 T5 12	1F	12	19.10	18.25	23.0	11	21	27	-	1	
27 T5 14	1F	14	22.29	21.45	25.0	13	21	27	-	2	
27 T5 15	1F	15	23.88	23.05	28.0	16	21	27	6	4	
27 T5 16	1F	16	25.47	24.60	32.0	18	21	27	6	5	
27 T5 18	1F	18	28.65	27.80	32.0	20	21	27	6	6	
27 T5 19	1F	19	30.25	29.40	36.0	22	21	27	6	8	
27 T5 20	1F	20	31.83	31.00	36.0	23	21	27	6	8	
27 T5 22	1F	22	35.02	34.15	38.0	24	21	27	6	9	
27 T5 24	1F	24	38.21	37.40	42.0	26	21	27	6	13	
27 T5 25	1F	25	39.80	38.95	44.0	26	21	27	6	12	
27 T5 26	1F	26	41.39	40.60	44.0	26	21	27	6	12	
27 T5 27	1F	27	42.98	42.20	48.0	30	21	27	8	11	
27 T5 28	1F	28	44.58	43.75	48.0	32	21	27	8	11	
27 T5 30	1F	30	47.76	46.95	51.0	34	21	27	8	16	
27 T5 32	1F	32	50.94	50.10	54.0	38	21	27	8	18	
27 T5 36	1F	36	57.31	56.45	64.0	38	21	27	8	23	
27 T5 40	1F	40	63.66	62.85	66.5	40	21	27	8	24	
27 T5 42	1F	42	66.86	66.00	70.0	40	21	27	8	26	
27 T5 44	2	44	70.05	69.20	-	45	21	27	8	-	
27 T5 48	2	48	76.42	75.55	-	50	21	27	8	-	
27 T5 60	2	60	95.52	94.65	-	65	21	27	8	-	

T 5 (5 mm pitch) DESIGNED FOR 25 mm WIDE BELTS

ALUMINIUM	DESCRIPTION	EXEC.	No. of TEETH	Dp	De	Df	Dm	F	L	d	FLANGE No.
	36 T5 10	1F	10	15.92	15.05	19.5	8	30	36	-	3
36 T5 12	1F	12	19.10	18.25	23.0	11	30	36	-	1	
36 T5 14	1F	14	22.29	21.45	25.0	13	30	36	-	2	
36 T5 15	1F	15	23.88	23.05	28.0	16	30	36	6	4	
36 T5 16	1F	16	25.47	24.60	32.0	18	30	36	6	5	
36 T5 18	1F	18	28.65	27.80	32.0	20	30	36	6	6	
36 T5 19	1F	19	30.25	29.40	36.0	22	30	36	6	8	
36 T5 20	1F	20	31.83	31.00	36.0	23	30	36	6	8	
36 T5 22	1F	22	35.02	34.15	38.0	24	30	36	6	9	
36 T5 24	1F	24	38.21	37.40	42.0	26	30	36	8	13	
36 T5 25	1F	25	39.80	38.95	44.0	26	30	36	8	12	
36 T5 26	1F	26	41.39	40.60	44.0	26	30	36	8	12	
36 T5 27	1F	27	42.98	42.20	48.0	30	30	36	8	11	
36 T5 28	1F	28	44.58	43.75	48.0	32	30	36	8	11	
36 T5 30	1F	30	47.76	46.95	51.0	34	30	36	8	16	
36 T5 32	1F	32	50.94	50.10	54.0	38	30	36	8	18	
36 T5 36	1F	36	57.31	56.45	64.0	38	30	36	8	23	
36 T5 40	1F	40	63.66	62.85	66.5	40	30	36	8	24	
36 T5 42	1F	42	66.86	66.00	70.0	40	30	36	8	26	
36 T5 44	2	44	70.05	69.20	-	45	30	36	8	-	
36 T5 48	2	48	76.42	75.55	-	50	30	36	8	-	
36 T5 60	2	60	95.52	94.65	-	65	30	36	8	-	

T20 pitch pulleys and bars are manufactured on request.

" T " P U L L E Y S

T 10 (10 mm pitch) DESIGNED FOR 16 mm WIDE BELTS

ALUMINIUM	DESCRIPTION	EXEC.	No. of TEETH	Dp	De	Df	Dm	F	L	d	FLANGE No.
	31 T10 12	1F	12	38.20	36.35	42	28	21	31	6	13
	31 T10 14	1F	14	44.56	42.70	48	32	21	31	8	11
	31 T10 15	1F	15	47.75	45.90	51	32	21	31	8	16
	31 T10 16	1F	16	50.93	49.10	54	35	21	31	8	18
	31 T10 18	1F	18	57.29	55.45	60	40	21	31	8	21
	31 T10 19	1F	19	60.48	58.65	66	44	21	31	8	24
	31 T10 20	1F	20	63.66	61.80	66	46	21	31	8	24
	31 T10 22	1F	22	70.03	68.20	75	52	21	31	8	27
	31 T10 24	1F	24	76.39	74.55	83	58	21	31	8	29
	31 T10 25	1F	25	79.58	77.75	83	60	21	31	8	29
	31 T10 26	1F	26	82.76	80.90	87	60	21	31	8	31
31 T10 27	1F	27	85.95	84.10	91	60	21	31	8	32	
31 T10 28	1F	28	89.12	87.25	93	60	21	31	8	33	
31 T10 30	1F	30	95.49	93.65	102	60	21	31	8	35	
31 T10 32	1F	32	101.86	100.00	106	65	21	31	10	38	
31 T10 36	1F	36	114.59	112.75	119	70	21	31	10	43	
31 T10 40	1F	40	127.32	125.45	131	80	21	31	10	47	
31 T10 44	2	44	140.05	138.20	-	88	21	31	10	-	
31 T10 48	2	48	152.78	150.95	-	95	21	31	16	-	
31 T10 60	2	60	190.98	189.10	-	110	21	31	16	-	

T 10 (10 mm pitch) DESIGNED FOR 25 mm WIDE BELTS

ALUMINIUM	DESCRIPTION	EXEC.	No. of TEETH	Dp	De	Df	Dm	F	L	d	FLANGE No.
	40 T10 12	1F	12	38.20	36.35	42	28	30	40	6	13
	40 T10 14	1F	14	44.56	42.70	48	32	30	40	8	11
	40 T10 15	1F	15	47.75	45.90	51	32	30	40	8	16
	40 T10 16	1F	16	50.93	49.10	54	35	30	40	8	18
	40 T10 18	1F	18	57.29	55.45	60	40	30	40	8	21
	40 T10 19	1F	19	60.48	58.65	66	44	30	40	8	24
	40 T10 20	1F	20	63.66	61.80	66	46	30	40	8	24
	40 T10 22	1F	22	70.03	68.20	75	52	30	40	8	27
	40 T10 24	1F	24	76.39	74.55	83	58	30	40	8	29
	40 T10 25	1F	25	79.58	77.75	83	60	30	40	8	29
	40 T10 26	1F	26	82.76	80.90	87	60	30	40	8	31
40 T10 27	1F	27	85.95	84.10	91	60	30	40	8	32	
40 T10 28	1F	28	89.12	87.25	93	60	30	40	8	33	
40 T10 30	1F	30	95.49	93.65	102	60	30	40	8	35	
40 T10 32	1F	32	101.86	100.00	106	65	30	40	10	38	
40 T10 36	1F	36	114.59	112.75	119	70	30	40	10	43	
40 T10 40	1F	40	127.32	125.45	131	80	30	40	10	47	
40 T10 44	2	44	140.05	138.20	-	88	30	40	10	-	
40 T10 48	2	48	152.78	150.95	-	95	30	40	16	-	
40 T10 60	2	60	190.98	189.15	-	110	30	40	16	-	

T20 pitch pulleys and bars are manufactured on request.

" T " P U L L E Y S

T 10 (10 mm pitch) DESIGNED FOR 32 mm WIDE BELTS

ALUMINIUM	DESCRIPTION	EXEC.	No. of TEETH	Dp	De	Df	Dm	F	L	d	FLANGE No.
	47 T10 18	1F	18	57.29	55.45	60	40	37	47	10	21
	47 T10 19	1F	19	60.48	58.60	66	44	37	47	10	24
	47 T10 20	1F	20	63.66	61.80	66	46	37	47	12	24
	47 T10 22	1F	22	70.03	68.20	75	52	37	47	12	27
	47 T10 24	1F	24	76.39	74.55	83	58	37	47	12	29
	47 T10 25	1F	25	79.58	77.75	83	60	37	47	12	29
	47 T10 26	1F	26	82.76	80.90	87	60	37	47	12	31
	47 T10 27	1F	27	85.95	84.10	91	60	37	47	12	32
	47 T10 28	1F	28	89.12	87.25	93	60	37	47	12	33
	47 T10 30	1F	30	95.49	93.65	102	60	37	47	12	35
	47 T10 32	1F	32	101.86	100.00	106	65	37	47	12	38
47 T10 36	1F	36	114.59	112.75	119	70	37	47	16	43	
47 T10 40	1F	40	127.32	125.45	131	80	37	47	16	47	
47 T10 44	2	44	140.05	138.20	-	88	37	47	16	-	
47 T10 48	2	48	152.78	150.95	-	95	37	47	16	-	
47 T10 60	2	60	190.98	189.10	-	110	37	47	16	-	

T 10 (10 mm pitch) DESIGNED FOR 50 mm WIDE BELTS

ALUMINIUM	DESCRIPTION	EXEC.	No. of TEETH	Dp	De	Df	Dm	F	L	d	FLANGE No.
	66 T10 18	1F	18	57.29	55.45	60	40	56	66	10	21
	66 T10 19	1F	19	60.48	58.65	66	44	56	66	10	24
	66 T10 20	1F	20	63.66	61.80	66	46	56	66	12	24
	66 T10 22	1F	22	70.03	68.20	75	52	56	66	12	27
	66 T10 24	1F	24	76.39	74.55	83	58	56	66	12	29
	66 T10 25	1F	25	79.58	77.70	83	60	56	66	12	29
	66 T10 26	1F	26	82.76	80.90	87	60	56	66	12	31
	66 T10 27	1F	27	85.95	84.10	91	60	56	66	12	32
	66 T10 28	1F	28	89.12	87.25	93	60	56	66	12	33
	66 T10 30	1F	30	95.49	93.65	102	60	56	66	12	35
	66 T10 32	1F	32	101.86	100.00	106	65	56	66	12	38
66 T10 36	1F	36	114.59	112.75	119	70	56	66	16	43	
66 T10 40	1F	40	127.32	125.45	131	80	56	66	16	47	
66 T10 44	2	44	140.05	138.20	-	88	56	66	16	-	
66 T10 48	2	48	152.78	150.95	-	95	56	66	16	-	
66 T10 60	2	60	190.98	189.10	-	110	56	66	16	-	

T20 pitch pulleys and bars are manufactured on request.

" T " B A R S

T 5 (5 mm pitch)

DESCRIPTION	No. of TEETH	De EXTERNAL	L WORKING	L TOTAL
T5-10	10	15.05	125	140
T5-11	11	16.65	125	140
T5-12	12	18.25	125	140
T5-13	13	19.85	125	140
T5-14	14	21.45	140	140
T5-15	15	23.05	140	140
T5-16	16	24.60	140	140
T5-17	17	26.20	140	140
T5-18	18	27.00	140	140
T5-19	19	29.40	140	140
T5-20	20	31.00	160	160
T5-21	21	32.70	160	160
T5-22	22	34.15	160	160
T5-23	23	35.85	160	160
T5-24	24	37.40	160	160
T5-25	25	38.95	160	160
T5-26	26	40.60	160	160
T5-27	27	42.20	160	160
T5-28	28	43.75	160	160
T5-29	29	45.35	160	160
T5-30	30	46.95	160	160
T5-32	32	50.10	160	160
T5-34	34	53.25	160	160
T5-35	35	54.85	160	160
T5-36	36	56.45	160	160
T5-37	37	58.06	160	160
T5-38	38	59.65	160	160
T5-40	40	62.85	160	160
T5-42	42	66.00	160	160
T5-44	44	69.20	160	160
T5-45	45	70.80	160	160
T5-46	46	72.40	160	160
T5-48	48	75.55	160	160
T5-50	50	78.75	160	160
T5-60	60	94.65	160	160
T5-72	72	113.75	160	160
T5-80	80	126.48	160	160
T5-90	90	142.40	160	160
T5-100	100	158.31	160	160

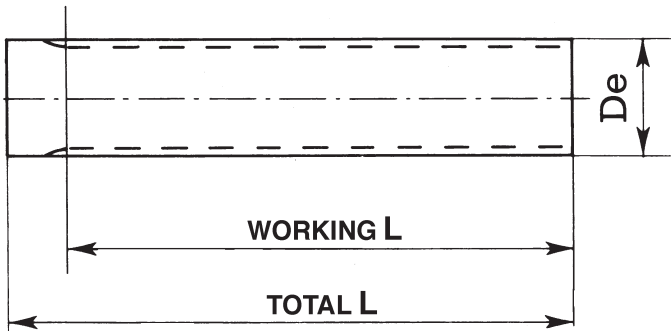

N.B. T 2.5 - T 5 - T 10 pitch bars are only manufactured in Aluminium suitable for hard anodising.

T20 pitch pulleys and bars are manufactured, on request

T 2.5 (2.5 mm pitch)

DESCRIPTION	No. of TEETH	De EXTERNAL	L WORKING	L TOTAL
T2.5-10	10	7.45	50	75
T2.5-12	12	9.00	50	75
T2.5-13	13	9.80	50	75
T2.5-14	14	10.60	50	75
T2.5-15	15	11.40	50	75
T2.5-16	16	12.20	50	75
T2.5-17	17	13.00	50	75
T2.5-18	18	13.80	50	75
T2.5-19	19	14.60	90	120
T2.5-20	20	15.40	90	120
T2.5-21	21	16.20	90	120
T2.5-22	22	17.00	125	140
T2.5-24	24	18.55	125	140
T2.5-26	26	20.15	125	140
T2.5-27	27	20.95	125	140
T2.5-28	28	21.75	125	140
T2.5-29	29	22.55	125	140
T2.5-30	30	23.35	125	140
T2.5-32	32	24.95	125	140
T2.5-34	34	26.55	125	140
T2.5-35	35	27.35	132	140
T2.5-36	36	28.10	132	140
T2.5-38	38	29.70	140	140
T2.5-40	40	31.30	140	140
T2.5-42	42	32.90	140	140
T2.5-44	44	34.50	140	140
T2.5-45	45	35.30	140	140
T2.5-48	48	37.70	140	140
T2.5-50	50	39.29	160	160
T2.5-60	60	47.25	160	160
T2.5-65	65	51.20	160	160
T2.5-70	70	55.20	160	160
T2.5-72	72	56.80	160	160
T2.5-90	90	71.12	160	160
T2.5-100	100	79.08	160	160

T 10 (10 mm pitch)

DESCRIPTION	No. of TEETH	De EXTERNAL	L WORKING	L TOTAL
T10-10	10	29.98	140	140
T10-11	11	33.16	140	140
T10-12	12	36.35	140	140
T10-13	13	39.55	140	140
T10-14	14	42.70	160	160
T10-15	15	45.90	160	160
T10-16	16	49.10	160	160
T10-17	17	52.25	160	160
T10-18	18	55.45	160	160
T10-19	19	58.65	160	160
T10-20	20	61.80	160	160
T10-21	21	65.00	160	160
T10-22	22	68.15	160	160
T10-23	23	71.35	160	160
T10-24	24	74.55	160	160
T10-26	26	80.90	160	160
T10-28	28	87.25	160	160
T10-30	30	93.65	160	160
T10-32	32	100.00	160	160
T10-34	34	106.40	160	160
T10-36	36	112.75	160	160
T10-38	38	119.10	160	160
T10-40	40	125.45	160	160
T10-45	45	141.40	160	160
T10-48	48	150.95	160	160
T10-60	60	189.15	160	160
T10-72	72	227.29	160	160

"CT" PULLEYS DESIGNED FOR "AT" BELTS

Dimensional features

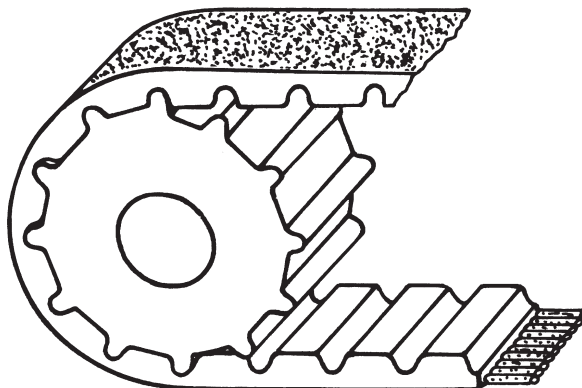

- P = Pitch
- Z = No. of teeth
- \varnothing_p = Pitch line diameter
- \varnothing_e = External diameter
- Lp = Pulley width
- Lc = Belt width
- Lpc = Belt pitch line length

Belt identification

- 16 AT10 440 {
- 16 = Belt width in mm.
 - AT10 = Toothing pitch in mm.
 - 440 = Pitch line length in mm.

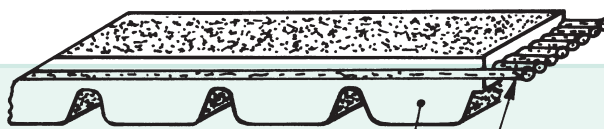

- A) Polyurethane belt body
- B) Steel reinforcing insert

N.B. The "AT" profile represents an optimised version of the 'T' metric pitch, ensures enhanced belt meshing with subsequent reduced noise levels, the power transmitted is greater than ~ 30% compared with the 'T' version.

Fields of application:

machine tools, electrical household appliances, textile machines, packing machines, typewriters, sewing machines, etc.

"AT" "MECTROL"® POLYURETHANE BELTS

AT 5 (5mm pitch)

Belt type	No. of teeth	Pitch line length
AT5-225	45	225
AT5-255	51	255
AT5-280	56	280
AT5-300	60	300
AT5-340	68	340
AT5-375	75	375
AT5-390	78	390
AT5-420	84	420
AT5-455	91	455
AT5-500	100	500
AT5-545	109	545
AT5-600	120	600
AT5-610	122	610
AT5-630	126	630
AT5-660	132	660
AT5-720	144	720
AT5-750	150	750
AT5-780	156	780
AT5-825	165	825
AT5-975	195	975
AT5-1050	210	1050
AT5-1125	225	1125
AT5-1500	300	1500

AT 10 (10mm pitch)

Belt type	No. of teeth	Pitch line length
AT10-500	50	500
AT10-560	56	560
AT10-610	61	610
AT10-660	66	660
AT10-700	70	700
AT10-730	73	730
AT10-780	78	780
AT10-800	80	800
AT10-840	84	840
AT10-890	89	890
AT10-920	92	920
AT10-960	96	960
AT10-980	98	980
AT10-1010	101	1010
AT10-1050	105	1050
AT10-1080	108	1080
AT10-1150	115	1150
AT10-1210	121	1210
AT10-1250	125	1250
AT10-1320	132	1320
AT10-1400	140	1400
AT10-1500	150	1500
AT10-1600	160	1600
AT10-1700	170	1700
AT10-1800	180	1800

PITCH SELECTION FOR "AT" METRIC PITCH "MECTROL"®

Power to be transmitted Kw

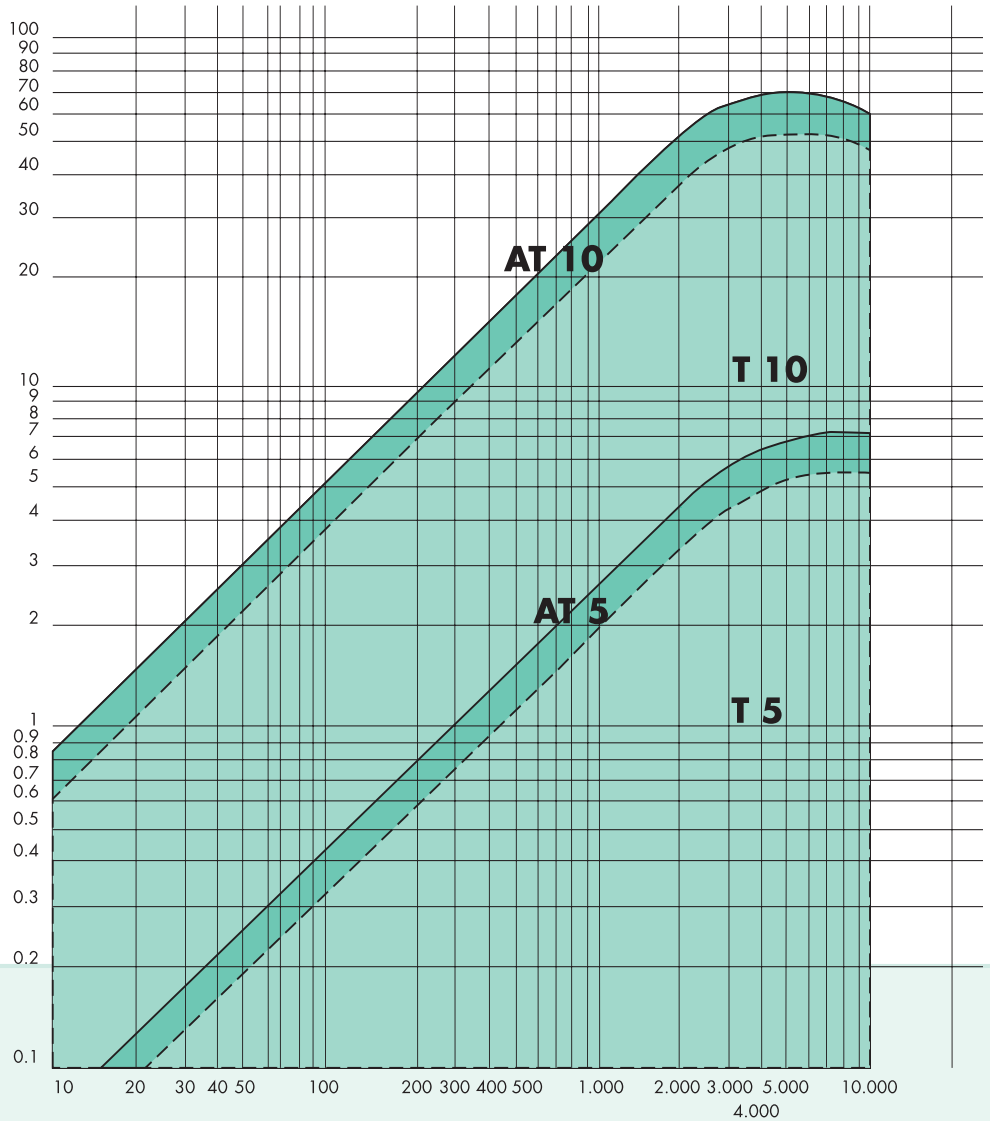

Number of r.p.m. of the smallest pulley

STANDARD BELT LENGTHS AND SHEARING TOLERANCES

Belt pitch	Belt width (mm)	Width tolerance (mm)
AT 5 (5 mm)	10	± 0.5
	16	
	25	
AT 10 (10 mm)	16	± 0.5
	25	
	32	
	50	

"CT" PULLEYS FOR "AT" POLYURETHANE BELTS

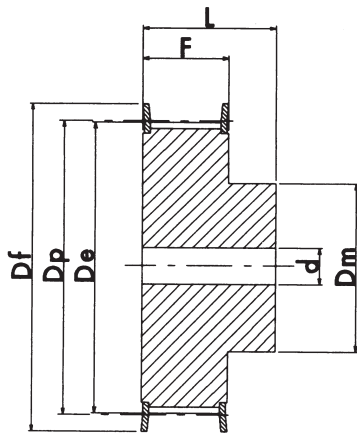

EXECUTION 1F

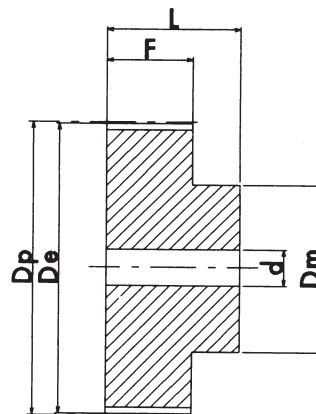

EXECUTION 2

How to identify a pulley - Example:
21 CT5 25

Pulley length (mm) **21**
 Pulley pitch (mm) **CT5**
 No. of teeth on pulley **25**

material: **ALUMINIUM**

CT5 (5 mm pitch) DESIGNED FOR 10 mm WIDE BELT

ALUMINIUM

DESCRIPTION	EXEC.	No. of TEETH	Dp	De	Df	Dm	F	L	d	FLANGE No.
21 CT5 12	1F	12	19.10	17.85	23.0	11	15	21	-	1
21 CT5 14	1F	14	22.29	21.05	25.0	13	15	21	-	2
21 CT5 15	1F	15	23.88	22.65	28.0	16	15	21	6	4
21 CT5 16	1F	16	25.47	24.20	32.0	18	15	21	6	5
21 CT5 18	1F	18	28.65	27.40	32.0	20	15	21	6	6
21 CT5 19	1F	19	30.25	29.00	36.0	22	15	21	6	8
21 CT5 20	1F	20	31.83	30.60	36.0	23	15	21	6	8
21 CT5 22	1F	22	35.02	33.85	38.0	24	15	21	6	9
21 CT5 24	1F	24	38.21	37.00	42.0	26	15	21	6	13
21 CT5 25	1F	25	39.80	38.60	44.0	26	15	21	6	12
21 CT5 26	1F	26	41.39	40.20	44.0	26	15	21	6	12
21 CT5 27	1F	27	42.98	41.80	48.0	30	15	21	8	11
21 CT5 28	1F	28	44.58	43.35	48.0	32	15	21	8	11
21 CT5 30	1F	30	47.76	46.55	51.0	34	15	21	8	16
21 CT5 32	1F	32	50.94	49.70	54.0	38	15	21	8	18
21 CT5 36	1F	36	57.31	56.05	64.0	38	15	21	8	23
21 CT5 40	1F	40	63.66	62.45	66.5	40	15	21	8	24
21 CT5 42	1F	42	66.86	65.60	70.0	40	15	21	8	26
21 CT5 44	2	44	70.05	68.80	-	45	15	21	8	-
21 CT5 48	2	48	76.42	75.15	-	50	15	21	8	-
21 CT5 60	2	60	95.52	94.25	-	65	15	21	8	-

"CT" PULLEYS FOR "AT" POLYURETHANE BELTS

CT5 (5 mm pitch) DESIGNED FOR 16 mm WIDE BELT

ALUMINIUM	DESCRIPTION	EXEC.	No. of TEETH	Dp	De	Df	Dm	F	L	d	FLANGE No.
	27 CT5 12	1F	12	19.10	17.85	23.0	11	21	27	-	1
27 CT5 14	1F	14	22.29	21.05	25.0	13	21	27	-	2	
27 CT5 15	1F	15	23.88	22.65	28.0	16	21	27	6	4	
27 CT5 16	1F	16	25.47	24.20	32.0	18	21	27	6	5	
27 CT5 18	1F	18	28.65	27.40	32.0	20	21	27	6	6	
27 CT5 19	1F	19	30.25	29.00	36.0	22	21	27	6	8	
27 CT5 20	1F	20	31.83	30.60	36.0	23	21	27	6	8	
27 CT5 22	1F	22	35.02	33.85	38.0	24	21	27	6	9	
27 CT5 24	1F	24	38.21	37.00	42.0	26	21	27	6	13	
27 CT5 25	1F	25	39.80	38.60	44.0	26	21	27	6	12	
27 CT5 26	1F	26	41.39	40.20	44.0	26	21	27	6	12	
27 CT5 27	1F	27	42.98	41.80	48.0	30	21	27	8	11	
27 CT5 28	1F	28	44.58	43.35	48.0	32	21	27	8	11	
27 CT5 30	1F	30	47.76	46.55	51.0	34	21	27	8	16	
27 CT5 32	1F	32	50.94	49.70	54.0	38	21	27	8	18	
27 CT5 36	1F	36	57.31	56.05	64.0	38	21	27	8	23	
27 CT5 40	1F	40	63.66	62.45	66.5	40	21	27	8	24	
27 CT5 42	1F	42	66.86	65.60	70	40	21	27	8	26	
27 CT5 44	2	44	70.05	68.80	-	45	21	27	8	-	
27 CT5 48	2	48	76.42	75.15	-	50	21	27	8	-	
27 CT5 60	2	60	95.52	94.25	-	65	21	27	8	-	

CT5 (5 mm pitch) DESIGNED FOR 25 mm WIDE BELT

ALUMINIUM	DESCRIPTION	EXEC.	No. of TEETH	Dp	De	Df	Dm	F	L	d	FLANGE No.
	36 CT5 12	1F	12	19.10	17.85	23.0	11	30	36	-	1
36 CT5 14	1F	14	22.29	21.05	25.0	13	30	36	-	2	
36 CT5 15	1F	15	23.88	22.65	28.0	16	30	36	6	4	
36 CT5 16	1F	16	25.47	24.20	32.0	18	30	36	6	5	
36 CT5 18	1F	18	28.65	27.40	32.0	20	30	36	6	6	
36 CT5 19	1F	19	30.25	29.00	36.0	22	30	36	6	8	
36 CT5 20	1F	20	31.83	30.60	36.0	23	30	36	6	8	
36 CT5 22	1F	22	35.02	33.85	38.0	24	30	36	6	9	
36 CT5 24	1F	24	38.21	37.00	42.0	26	30	36	6	13	
36 CT5 25	1F	25	39.80	38.60	44.0	26	30	36	6	12	
36 CT5 26	1F	26	41.39	40.20	44.0	26	30	36	6	12	
36 CT5 27	1F	27	42.98	41.80	48.0	30	30	36	8	11	
36 CT5 28	1F	28	44.58	43.35	48.0	32	30	36	8	11	
36 CT5 30	1F	30	47.76	46.55	51.0	34	30	36	8	16	
36 CT5 32	1F	32	50.94	49.70	54.0	38	30	36	8	18	
36 CT5 36	1F	36	57.31	56.05	64.0	38	30	36	8	23	
36 CT5 40	1F	40	63.66	62.45	66.5	40	30	36	8	24	
36 CT5 42	1F	42	66.86	65.60	70.0	40	30	36	8	26	
36 CT5 44	2	44	70.05	68.80	-	45	30	36	8	-	
36 CT5 48	2	48	76.42	75.15	-	50	30	36	8	-	
36 CT5 60	2	60	95.52	94.25	-	65	30	36	8	-	

CT20 pitch pulleys and bars are manufactured on request.

"CT" PULLEYS FOR "AT" POLYURETHANE BELTS

CT10 (10 mm pitch) DESIGNED FOR 16 mm WIDE BELT

ALUMINIUM	DESCRIPTION	EXEC.	No. of TEETH	Dp	De	Df	Dm	F	L	d	FLANGE No.
	31 CT10 15	1F	15	47.75	45.90	51	32	21	31	8	16
	31 CT10 16	1F	16	50.93	49.05	54	35	21	31	8	18
	31 CT10 18	1F	18	57.29	55.45	60	40	21	31	8	21
	31 CT10 19	1F	19	60.48	58.60	66.5	44	21	31	8	24
	31 CT10 20	1F	20	63.66	61.80	66.5	46	21	31	8	24
	31 CT10 22	1F	22	70.03	68.15	75	52	21	31	8	27
	31 CT10 24	1F	24	76.39	74.55	83	58	21	31	8	29
	31 CT10 25	1F	25	79.58	77.70	83	60	21	31	8	29
	31 CT10 26	1F	26	82.76	80.90	87	60	21	31	8	31
	31 CT10 27	1F	27	85.95	84.10	91	60	21	31	8	32
31 CT10 28	1F	28	89.12	87.25	93	60	21	31	8	33	
31 CT10 30	1F	30	95.49	93.65	102	60	21	31	8	35	
31 CT10 32	1F	32	101.86	100.00	106	65	21	31	10	38	
31 CT10 36	1F	36	114.59	112.75	119	70	21	31	10	43	
31 CT10 40	1F	40	127.32	125.45	131	80	21	31	10	47	
31 CT10 44	2	44	140.05	138.20	-	88	21	31	10	-	
31 CT10 48	2	48	152.78	150.95	-	95	21	31	16	-	
31 CT10 60	2	60	190.98	189.10	-	110	21	31	16	-	

CT10 (10 mm pitch) DESIGNED FOR 25 mm WIDE BELT

ALUMINIUM	DESCRIPTION	EXEC.	No. of TEETH	Dp	De	Df	Dm	F	L	d	FLANGE No.
	40 CT10 15	1F	15	47.75	45.90	51	32	30	40	8	16
	40 CT10 16	1F	16	50.93	49.05	54	35	30	40	8	18
	40 CT10 18	1F	18	57.29	55.45	60	40	30	40	8	21
	40 CT10 19	1F	19	60.48	58.60	66.5	44	30	40	8	24
	40 CT10 20	1F	20	63.66	61.80	66.5	46	30	40	8	24
	40 CT10 22	1F	22	70.03	68.15	75	52	30	40	8	27
	40 CT10 24	1F	24	76.39	74.55	83	58	30	40	8	29
	40 CT10 25	1F	25	79.58	77.70	83	60	30	40	8	29
	40 CT10 26	1F	26	82.76	80.90	87	60	30	40	8	31
	40 CT10 27	1F	27	85.95	84.10	91	60	30	40	8	32
40 CT10 28	1F	28	89.12	87.25	93	60	30	40	8	33	
40 CT10 30	1F	30	95.49	93.65	102	60	30	40	8	35	
40 CT10 32	1F	32	101.86	100.00	106	65	30	40	10	38	
40 CT10 36	1F	36	114.59	112.75	119	70	30	40	10	43	
40 CT10 40	1F	40	127.32	125.45	131	80	30	40	10	47	
40 CT10 44	2	44	140.05	138.20	-	88	30	40	10	-	
40 CT10 48	2	48	152.78	150.95	-	95	30	40	16	-	
40 CT10 60	2	60	190.98	189.10	-	110	30	40	16	-	

CT20 pitch pulleys and bars are manufactured on request.

"CT" PULLEYS FOR "AT" POLYURETHANE BELTS

CT10 (10 mm pitch) DESIGNED FOR 32 mm WIDE BELT

ALUMINIUM	DESCRIPTION	EXEC.	No. of TEETH	Dp	De	Df	Dm	F	L	d	FLANGE No.
	47 CT10 18	1F	18	57.29	55.45	60	40	37	47	10	21
	47 CT10 19	1F	19	60.48	58.60	66.5	44	37	47	10	24
	47 CT10 20	1F	20	63.66	61.80	66.5	46	37	47	12	24
	47 CT10 22	1F	22	70.03	68.15	75	52	37	47	12	27
	47 CT10 24	1F	24	76.39	74.55	83	58	37	47	12	29
	47 CT10 25	1F	25	79.58	77.70	83	60	37	47	12	29
	47 CT10 26	1F	26	82.76	80.90	87	60	37	47	12	31
	47 CT10 27	1F	27	85.95	84.10	91	60	37	47	12	32
	47 CT10 28	1F	28	89.12	87.25	93	60	37	47	12	33
	47 CT10 30	1F	30	95.49	93.65	102	60	37	47	12	35
	47 CT10 32	1F	32	101.86	100.00	106	65	37	47	12	38
	47 CT10 36	1F	36	114.59	112.75	119	70	37	47	16	43
	47 CT10 40	1F	40	127.32	125.45	131	80	37	47	16	47
	47 CT10 44	2	44	140.05	138.20	-	88	37	47	16	-
	47 CT10 48	2	48	152.78	150.95	-	95	37	47	16	-
47 CT10 60	2	60	190.98	189.10	-	110	37	47	16	-	

CT10 (10 mm pitch) DESIGNED FOR 50 mm WIDE BELT

ALUMINIUM	DESCRIPTION	EXEC.	No. of TEETH	Dp	De	Df	Dm	F	L	d	FLANGE No.
	66 CT10 18	1F	18	57.29	55.45	60	40	56	66	10	21
	66 CT10 19	1F	19	60.48	58.60	66.5	44	56	66	10	24
	66 CT10 20	1F	20	63.66	61.80	66.5	46	56	66	12	24
	66 CT10 22	1F	22	70.03	68.15	75	52	56	66	12	27
	66 CT10 24	1F	24	76.39	74.55	83	58	56	66	12	29
	66 CT10 25	1F	25	79.58	77.70	83	60	56	66	12	29
	66 CT10 26	1F	26	82.76	80.90	87	60	56	66	12	31
	66 CT10 27	1F	27	85.95	84.10	91	60	56	66	12	32
	66 CT10 28	1F	28	89.12	87.25	93	60	56	66	12	33
	66 CT10 30	1F	30	95.49	93.65	102	60	56	66	12	35
	66 CT10 32	1F	32	101.86	100.00	106	65	56	66	12	38
	66 CT10 36	1F	36	114.59	112.75	119	70	56	66	16	43
	66 CT10 40	1F	40	127.32	125.45	131	80	56	66	16	47
	66 CT10 44	2	44	140.05	138.20	-	88	56	66	16	-
	66 CT10 48	2	48	152.78	150.95	-	95	56	66	16	-
66 CT10 60	2	60	190.98	189.10	-	110	56	66	16	-	

CT20 pitch pulleys and bars are manufactured on request.

"CT" BARS FOR "AT" POLYURETHANE BELTS

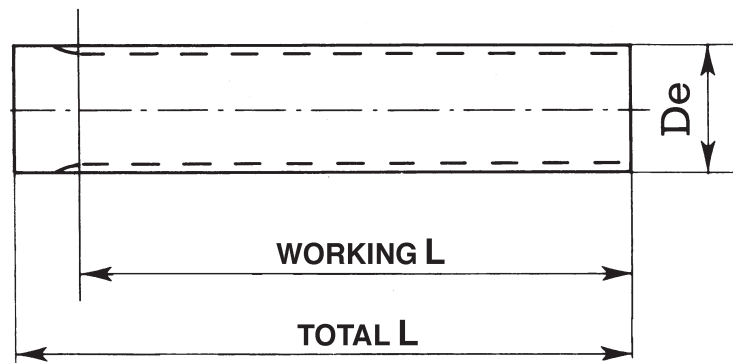

N.B. CT 5 - CT 10 pitch bars are only manufactured in Aluminium suitable for hard oxidation to thickness.

CT5 (5 mm pitch)

DESCRIPTION	No. of TEETH	De EXTERNAL	L WORKING	L TOTAL
CT5-12	12	17.85	140	140
CT5-13	13	19.45	140	140
CT5-14	14	21.05	140	140
CT5-15	15	22.65	140	140
CT5-16	16	24.20	140	140
CT5-18	18	27.40	140	140
CT5-19	19	29.00	140	140
CT5-20	20	30.60	160	160
CT5-21	21	32.30	160	160
CT5-22	22	33.85	160	160
CT5-23	23	35.45	160	160
CT5-24	24	37.00	160	160
CT5-25	25	38.55	160	160
CT5-26	26	40.20	160	160
CT5-28	28	43.25	160	160
CT5-30	30	46.55	160	160
CT5-32	32	49.70	160	160
CT5-34	34	52.85	160	160
CT5-36	36	56.05	160	160
CT5-38	38	59.25	160	160
CT5-40	40	62.45	160	160
CT5-42	42	65.60	160	160
CT5-44	44	68.80	160	160
CT5-46	46	72.00	160	160
CT5-48	48	75.15	160	160
CT5-52	52	81.55	160	160
CT5-56	56	87.90	160	160
CT5-60	60	94.25	160	160
CT5-64	64	100.65	160	160
CT5-72	72	113.35	160	160

CT10 (10 mm pitch)

DESCRIPTION	No. of TEETH	De EXTERNAL	L WORKING	L TOTAL
CT10-15	15	45.90	160	160
CT10-16	16	49.140	160	160
CT10-18	18	55.45	160	160
CT10-19	19	58.65	160	160
CT10-20	20	61.80	160	160
CT10-21	21	65.00	160	160
CT10-22	22	68.20	160	160
CT10-23	23	71.35	160	160
CT10-24	24	74.55	160	160
CT10-25	25	77.75	160	160
CT10-26	26	80.90	160	160
CT10-28	28	87.25	160	160
CT10-30	30	93.65	160	160
CT10-32	32	100.00	160	160
CT10-34	34	106.40	160	160
CT10-36	36	112.75	160	160
CT10-38	38	119.10	160	160
CT10-40	40	125.45	160	160
CT10-42	42	131.85	160	160
CT10-44	44	138.20	160	160
CT10-46	46	144.55	160	160
CT10-48	48	150.95	160	160
CT10-52	52	163.65	160	160
CT10-56	56	176.40	160	160
CT10-60	60	189.15	160	160

CT20 pitch pulleys and bars are manufactured on request

COMPACT DRIVE APPLICATIONS POLYFLEX V-BELTS

POLYURETHANE POLIFLEX® V-BELTS

This strong and compact V-belt is available in several nominal width dimensions **3-5-7-11 M** (mm) and it gives high speed applications higher power and precision. Poliflex is especially designed to fit very small diameters and ultra-compact transmissions with high speed rotation. It is well indicated for machine tools and high performance units, which require continuous operating in little space, such as milling machines, turning lathe, wood and metal processing units.

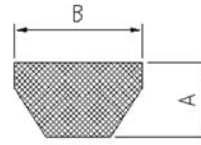

SECTION AND NOMINAL DIMENSIONS

TYPE	A	B
3M	2,3	3
5M	3,3	5
7M	5,3	7
11M	7,1	11

BELT TYPE

3M			5M			7M			11M		
LENGTH			LENGTH			LENGTH			LENGTH		
180	307	530	280	515	950	500	925	1700	710	1280	
185	315	545	290	530	975	515	950	1750	730	1320	
190	325	560	300	545	1000	530	975	1800	750	1360	
195	335	580	307	560	1030	545	1000	1850	775	1400	
200	345	600	315	580	1060	560	1030	1900	800	1450	
206	355	615	325	600	1090	580	1060	1950	825	1500	
212	365	630	335	615	1120	600	1090	2000	850	1550	
218	375	650	345	630	1150	615	1120	2060	875	1600	
224	387	670	355	650	1180	630	1150	2120	900	1650	
230	400	690	365	670	1220	650	1180	2180	925	1700	
236	412	710	375	690	1250	670	1220	2240	950	1750	
243	425	730	387	710	1280	690	1250	2300	975	1800	
250	437	750	400	730	1320	710	1280		1000	1850	
258	450		412	750	1360	730	1320		1030	1900	
265	462		425	775	1400	750	1360		1060	1950	
272	475		437	800	1450	775	1400		1090	2000	
280	487		450	825	1500	800	1450		1120	2060	
290	500		462	850	1600	825	1500		1150	2120	
300	515		475	875	1650	850	1550		1180	2180	
			487	900	1850	875	1600		1220	2240	
			500	925		900	1650		1250	2300	

COMPACT DRIVE APPLICATIONS POLYFLEX JB V-BELTS

POLYURETHANE POLIFLEX® MULTIPLE V-BELTS

Poliflex JB V-belt is a very high and uniform powered belt used in little space. Poliflex JB V-belt allow to small high precision transmissions, which use multiple belts, bigger load and higher speed. It is the perfect solution for all machine tools and small compressors.

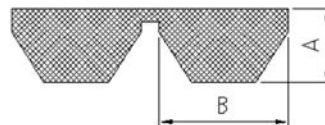

SECTION AND NOMINAL DIMENSIONS

TIPO	A	B
5M - JB	3,3	5
7M - JB	5,3	7
11M - JB	7,1	11

BELT TYPE

5M - JB				7M - JB				11M - JB			
LENGTH			N° STRANDS	LENGTH			N° STRANDS	LENGTH			N° STRANDS
280	500	900	2 - 3	500	900	1600	2 - 3	710	1250	2240	2 - 3
290	515	925	2 - 3	515	925	1650	2 - 3	730	1280	2300	2 - 3
300	530	950	2 - 3	530	950	1700	2 - 3	750	1320		2 - 3
307	545	975	2 - 3	545	975	1750	2 - 3	775	1360		2 - 3
315	560	1000	2 - 3	560	1000	1800	2 - 3	800	1400		2 - 3
325	580	1030	2 - 3	580	1030	1850	2 - 3	825	1450		2 - 3
335	600	1060	2 - 3	600	1060	1900	2 - 3	850	1500		2 - 3
345	615	1090	2 - 3	615	1090	1950	2 - 3	875	1550		2 - 3
355	630	1120	2 - 3	630	1120	2000	2 - 3	900	1600		2 - 3
365	650	1150	2 - 3	650	1150	2060	2 - 3	925	1650		2 - 3
375	670	1180	2 - 3	670	1180	2120	2 - 3	950	1700		2 - 3
387	690	1220	2 - 3	690	1220	2180	2 - 3	975	1750		2 - 3
400	710	1250	2 - 3	710	1250	2240	2 - 3	1000	1800		2 - 3
412	730	1280	2 - 3	730	1280	2300	2 - 3	1030	1850		2 - 3
425	750	1320	2 - 3	750	1320		2 - 3	1060	1900		2 - 3
437	775	1360	2 - 3	775	1360		2 - 3	1090	1950		2 - 3
450	800	1400	2 - 3	800	1400		2 - 3	1120	2000		2 - 3
462	825	1450	2 - 3	825	1450		2 - 3	1150	2060		2 - 3
475	850	1500	2 - 3	850	1500		2 - 3	1180	2120		2 - 3
487	875		2 - 3	875	1550		2 - 3	1220	2180		2 - 3

Not available on stock, only upon request

CLAMPING PLATES

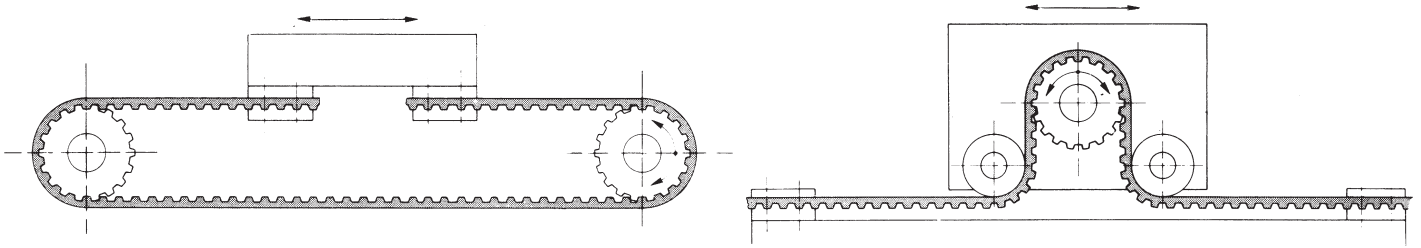

Anchoring belts by using clamping plates enables the rotary motion of the pulleys to be translated into a linear motion of boards or other particularly suitable devices to clamp the belts lengthwise.

CLAMPING PLATES DESIGNED FOR POWERGRIP® POSITIVE BELTS

PITCH	F	d	B	A	S	L (belt width)				
						025	037	050	075	100
						C				
XL	6	5.5	3.5	42.5	8	25.5	28.5			
L	8	9.0	5.0	76.6	15			39	45	51.5
H	10	11.0	9.0	106.9	22			45	51	57.5

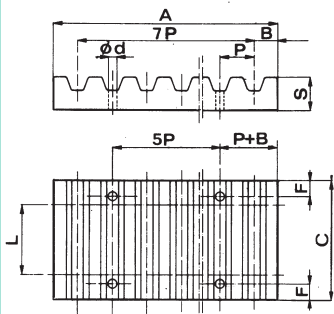

CLAMPING PLATES DESIGNED FOR POWERGRIP® HDT® METRIC BELTS

PITCH	F	d	B	A	S	L (belt width)											
						9	15	20	25	30	40	50	55	85	115	170	
						C											
5M	6	5,5	3,2	41,5	8	28	34		44								
8M	8	9	5	66	15			45		55		75		110			
14M	10	11	9	116	22					71		86	116	146	201		

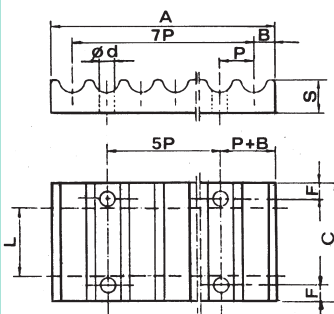

CLAMPING PLATES DESIGNED FOR "T" METRIC PITCH BELTS

PITCH	F	d	B	A	S	L (belt width)				
						10	16	25	32	50
						C				
T5	6	5.5	3.2	41.8	8	29	35	44		
T10	8	9	5	80	15		41	50	57	75

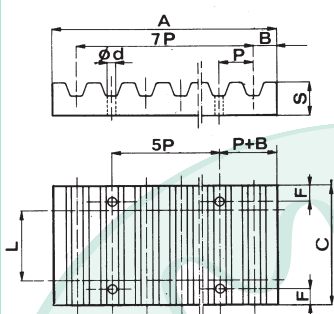

CT CLAMPING PLATES DESIGNED FOR "AT" METRIC PITCH BELTS

PITCH	F	d	B	A	S	L (belt width)				
						10	16	25	32	50
						C				
CT5	6	5.5	3.2	41.8	8	29	35	44		
CT10	8	9.0	5.0	80.0	15		41	50	57	75

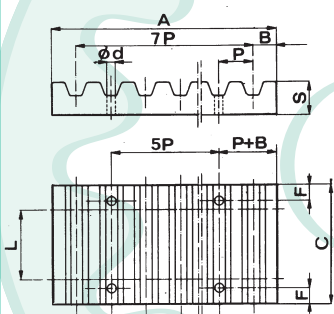

MATERIAL: ALUMINIUM

FLANGES FOR PULLEYS

TYPICAL PULLEY

No. of teeth on pulley	MXL	XL	L	H	XH	XXH	GT 3MR HTD 3M	GT 5MR HTD 5M	HTD 8M	HTD 14M	PC GT 8M	PC GT 14M	T 2,5	CT 5 T 5	CT 10 T 10
	FLANGE No.														
10		1	50				501							3	7
11		1	50											1	9
12		2	52				502	14					501	1	13
13		2	83										501	2	12
14		4	54	59			503	2					502	2	11
15		4	55	60			516	4					502	4	16
16	502	5	56	61			504	4					503	5	18
17		6	57	62									503	5	20
18	503	7	58	63	155	163	505	6					504	6	21
19		7	59	64	156								505	8	24
20	503	9	60	76	157	165	517	8					505	8	24
21		9	61	66	158		518	9					505	9	26
22	504	10	62	67	159	169	518	15	53		53		512	9	27
23		13	63	68									512	10	27
24	505	12	63	70	161	173	518	13	69				512	13	29
25		12	64	71	162						61		506	12	29
26		11	65	72	163	178	508	12	61				507	12	31
27		11	65	74	164								507	11	32
28	506	16	66	75	165		509	11	79	153	79	153	507	11	33
29		16	75										507	16	
30	506	18	68	78	167		509	16	73	154	82	154	508	16	35
32	507	20	70	80	169		510	18	76	160	76	160	509	18	38
33			71	81									509		
34		22	72	81	170			20	66	166	66	171	509	21	72
35		22	72	85									509	22	
36	508	23	74	85			519	21	68	168	68	168	510	23	43
37													510	23	
38		24		86				24	70	172	70	172	510	24	78
39		24													
40	509	26	78	90			513	25	77	162	77	174	511	24	47
41		26													
42	509	27	80	94									511	26	
43		27													
44	510	27	81	95			520	27	75	175		175	513	27	
45			81	96							75			27	85
46														29	
48		29	85	100				29	78	180	78	180	513	29	86
50											80	169	514	31	
56		35						33	85	182	85	182			
60		38									86				
64								38	90	184	90		515	38	100
72								43	97						

FLANGE DIMENSIONS FOR PULLEYS

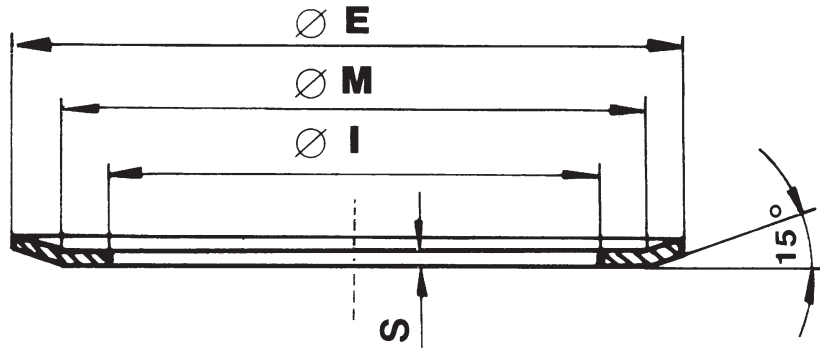

Flange No.	Thickness "S" = 0.5mm			Flange No.	Thickness "S" = 1mm			Flange No.	Thickness "S" = 1.5mm			Flange No.	Thickness "S" = 2.5mm		
	Ø E	Ø I	Ø M		Ø E	Ø I	Ø M		Ø E	Ø I	Ø M		Ø E	Ø I	Ø M
501	13	6	10	1	23	12.5	18	50	37	25	33	150			
502	15	8	12	2	25	15	21.5	51	39	28	34.5	151			
503	16	9.5	13	3	19.5	12	17.5	52	43	31	39	152			
504	17.5	11.6	14.5	4	28	17.8	24	53	60	47	57	153	128	107	124
505	20	12.2	16.5	5	32	20	26	54	48	37	42	154	138	112	131
506	25	14.5	21.5	6	32	23	27.5	55	51	38.5	45	155	140	107	125
507	26	17.8	24	7	35	23	30.5	56	54	43	48	156	146	107	133
508	28	20	25	8	36	25	31	57	57	46	51	157	155	107	139
509	32	23	27.5	9	38	26.5	34	58	60	48	54.2	158	160	120	148
510	36	25	31	10	41	30	36	59	64	47	57	159	170	120	153
511	38	26.5	34	11	48	37	43.5	60	66.5	53	60.2	160	154	122	142
512	22	14.5	19	12	44	32.5	40.5	61	70	53	64	161	184	135	168
513	42	30.5	38	13	42	30.5	38	62	75	57	68	162	188	150	176
514	44	32.5	40.5	14	23	14	20	63	79	60	72.5	163	198	150	180
515	51	40	47	15	39	28	34.5	64	82.5	64	76	164	205	160	189
516	17.5	10.5	14.5	16	51	40	47	65	86	68	81.5	165	212	162	200
517	23	14	20	17				66	91	73	86	166	160	130	150
518	25	15	21.5	18	54	43	50.5	67	94	76	88	167	227	176	210
519	39	28	34.5	19				68	97	79	92	168	168	135	162
520	48	37	43.5	20	57	47	51.5	69	66	52	61.5	169	240	192	224
				21	60	47	57	70	102	82.5	97	170	256	220	240
				22	61	49	56.5	71	106	86	100	171	160	136	150
				23	64	47	57	72	112	91	105.5	172	183	145	170
				24	66.5	52	63	73	83	68	76.5	173	267	220	240
				25	71	56	64	74	115	94	109	174	188	160	177
				26	70	53	66.5	75	120	99.5	112.5	175	211	173	198
				27	75	60	68.5	76	87	72	82.5	176			
				28				77	106	90	101	177	297	249	280
				29	83	68	78	78	128	107	121	178	290	230	260
				30				79	75	60	70.5	179			
				31	87	72	82.5	80	135	115	128.5	180	226	190	214
				32	91	76	85.5	81	142	120	137	181			
				33	93	80	89	82	82.5	67	76	182	256	225	247
				34				83	44	32.5	40.5	183			
				35	102	83	93.8	84				184	296	260	287
				36				85	150	130	145				
				37				86	158	138.5	153				
				38				87							
				39	106	90	101	88							
				40				89							
				41				90	168	148	161				
				42				91							
				43	119	103	113.5	92							
				44				93							
				45				94	180	154	174				
				46				95	184	162	177				
				47	131	115	125.5	96	192	165	181.5				
								97	192	173	187				
								98							
								99							
								100	200	180	193				

TAPER BUSHES ADAPTERS

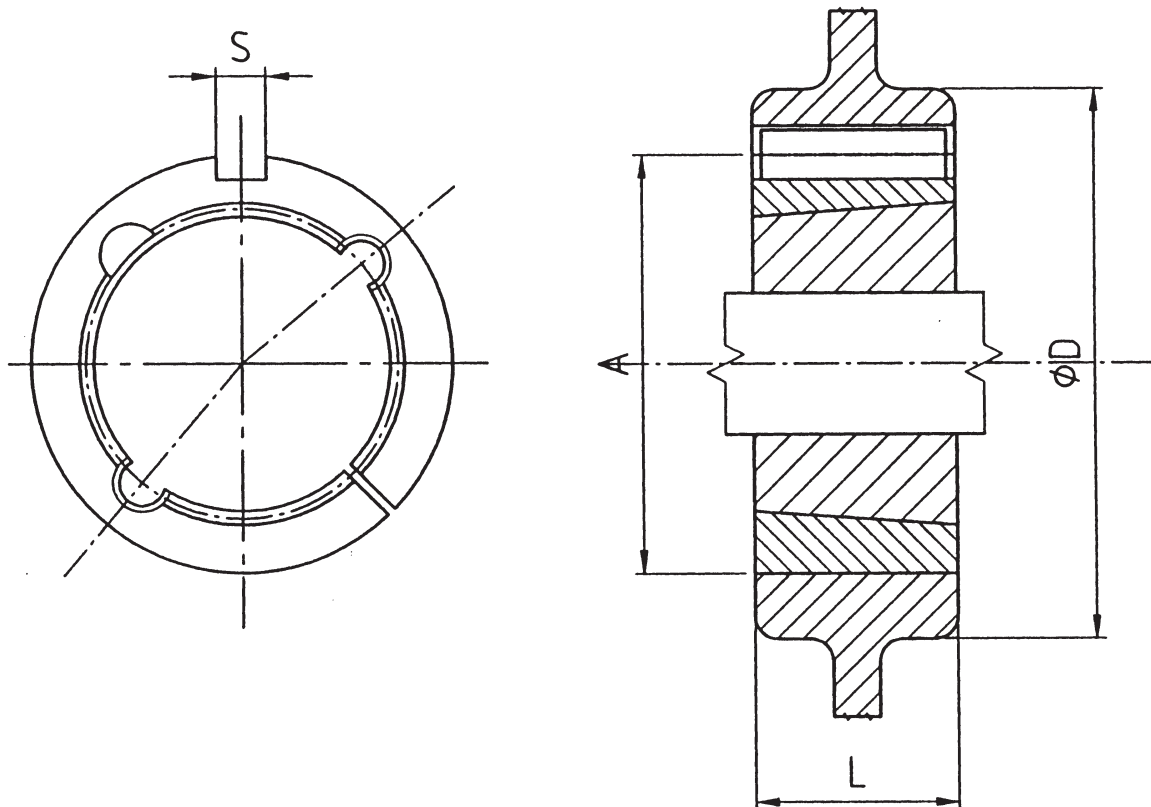

Adapter Type	Bush No.	L	A	Hub minimum Ø D		S
				Cast Iron	Steel	
A-CH 1008	1008	22	45	75	60	5 x 5
A-CH 1210	1210	25	60	105	85	6 x 6
A-CH 1610	1610	25	70	115	95	10 x 8
A-CH 1615	1615	38	70	115	95	10 x 8
A-CH 2517	2517	45	105	150	130	16 x 10
A-CH 3030	3030	76	130	190	160	20 x 12
A-CH 3535	3535	90	160	240	200	22 x 12
A-CH 4040	4040	102	185	290	240	24 x 12

" R C B " ® T A P E R B U S H E S

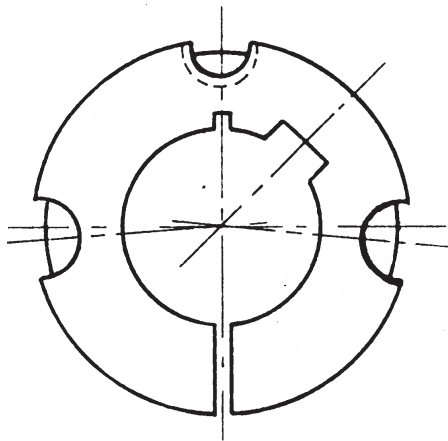

EXECUTION A
No. 3 BORES

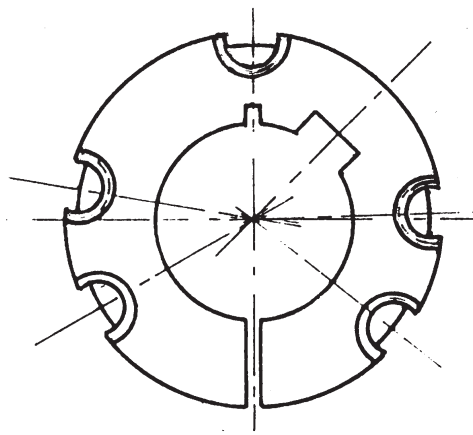

EXECUTION B
No. 5 BORES

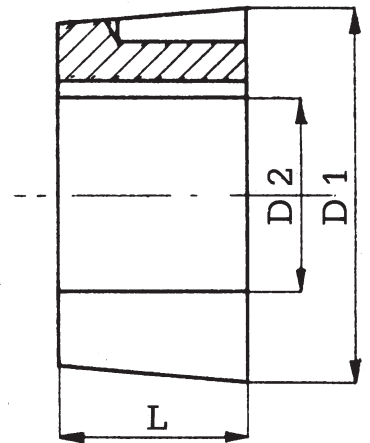

METRIC RANGE: BORES in mm. ISO G7 - Slots in compliance with DIN. 6885 - JS9

Bush Type	EXEC.	L	D1	Only pilot bore D2 H8	D2 Bore	B.S.W. screws	Tightening torque in N/m
1008	A	22	35	8	10 - 12 - 14 - 16 - 18 - 19 - 20 - 22 - 24 - 25	1/4" x 1/2"	5.6
1108	A	22	38	12	14 - 19 - 20 - 24 - 25	1/4" x 1/2"	5.6
1210	A	25	47.5	12	14 - 16 - 18 - 19 - 20 - 24 - 25 - 28 - 30 - 32	3/8" x 5/8"	19.6
1215	A	38	47.5	12	14 - 19 - 20 - 24 - 25 - 28	3/8" x 5/8"	19.6
1610	A	25	57	12	14 - 16 - 19 - 20 - 24 - 25 - 28 - 30 - 32 - 35 - 38 - 40 - 42	3/8" x 5/8"	19.6
1615	A	38	57	12	19 - 20 - 22 - 24 - 25 - 28 - 30 - 32 - 35 - 38 - 40	3/8" x 5/8"	19.6
2012	A	32	70	16	19 - 20 - 24 - 25 - 28 - 30 - 32 - 35 - 38 - 40 - 42 - 45 - 48 - 50	7/16" x 7/8"	30.4
2517	A	45	85.5	15	19 - 20 - 24 - 25 - 28 - 30 - 32 - 35 - 38 - 40 - 42 - 45 - 48 - 50 - 55 - 60 - 65	1/2" x 1"	48
3020	A	51	108	20	28 - 30 - 32 - 35 - 38 - 40 - 42 - 45 - 48 - 50 - 55 - 60 - 65 - 70 - 75	5/8" x 1" 1/4	90
3030	A	76	108	30	38 - 42 - 45 - 48 - 50 - 55 - 60	5/8" x 1" 1/2	90
3525	B	65	127	30	38 - 40 - 42 - 45 - 48 - 50 - 55 - 60 - 65 - 70 - 75 - 80	1/2" x 1" 1/2	113
3535	B	89	127	30	40 - 42 - 45 - 48 - 50 - 55 - 60 - 65 - 70 - 75 - 80 - 85 - 90	1/2" x 1" 1/2	113
4030	B	76	146	30	40 - 42 - 45 - 48 - 50 - 55 - 60 - 65 - 70 - 75 - 80 - 90	5/8" x 1" 1/2	169
4040	B	102	146	35	50 - 55 - 60 - 65 - 70 - 75 - 80 - 85 - 90 - 95	5/8" x 1" 3/4	169
4535	B	89	162	30	65 - 70 - 75 - 80 - 85 - 90 - 95 - 100 - 110 - 120	3/4" x 2"	192
4545	B	115	162	35	65 - 70 - 75 - 80 - 85 - 90 - 95 - 100 - 110	3/4" x 2"	192
5040	B	102	177.6	50	70 - 75 - 80 - 85 - 90 - 100 - 110 - 120 - 125	7/8" x 2" 1/4	272
5050	B	127	177.6	50	70 - 75 - 80 - 85 - 90 - 95 - 100 - 110 - 115 - 120 - 125	7/8" x 2" 1/4	272

WELDABLE HUBS FOR TAPER-LOCK® BUSH

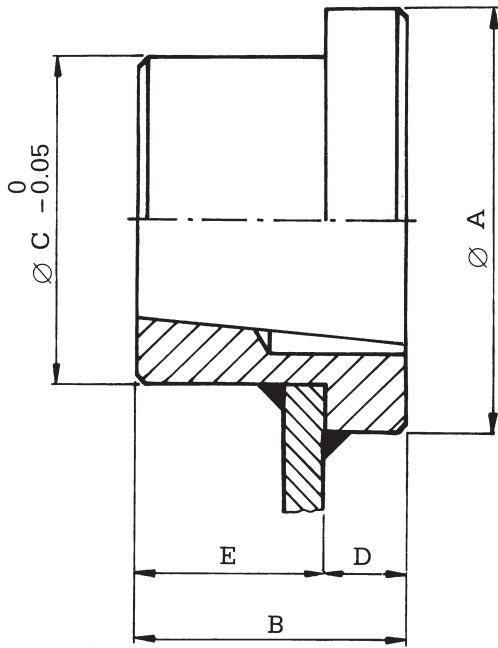

MATERIAL: Fe 50

TYPE	BUSH	ØA	B	ØC	D	E
MS. T. L. 1210	1210	70	25	65	9	16
MS. T. L. 1610	1610	80	25	75	9	16
MS. T. L. 2012	2012	95	32	90	12	20
MS. T. L. 2517	2517	115	45	110	19	26
MS. T. L. 3020	3020	145	51	140	19	32
MS. T. L. 3030	3030	145	76	140	19	57
MS. T. L. 3525	3525	190	65	180	25	40
MS. T. L. 3535	3535	190	89	180	25	64
MS. T. L. 4040	4040	200	102	190	32	70
MS. T. L. 4545	4545	220	115	205	38	77
MS. T. L. 5050	5050	240	127	220	38	89

TAPER HUBS

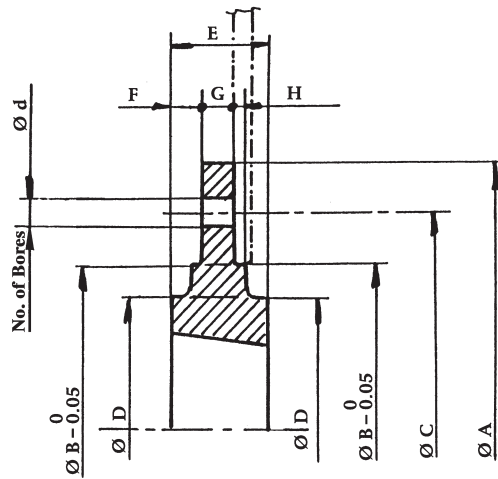

TYPE

CAST IRON

TYPE	BUSH	ØA	ØB	ØC	ØD	E	F	G	H	No. of bores	Ød
MSM T.L. Ø 120	1210	120	80	100	70	25	9	7.5	2.5	6	7.5
MSM T.L. Ø 130	1610	130	90	110	80	25	9	7.5	2.5	6	7.5
MSM T.L. Ø 145	2012	145	115	125	95	32	12	9.5	2.5	6	9.5
MSM T.L. Ø 185	2517	185	130	155	115	45	19	12.5	2.5	6	11.5
MSM T.L. Ø 220	3020	220	165	190	145	51	19	12.5	2.5	6	13.5

TYPE

CAST IRON - (*) STEEL

TYPE	BUSH	ØA	ØB	ØC	ØD	E	F	G	H	No. of bores	Ød
MSM T.L. Ø 180	1210	180	90	135	75	25	9.25	6.5	2.5	6	7.5
MSM T.L. Ø 200	1615	200	110	150	85	38	15.3	7.5	2.5	6	7.5
MSM T.L. Ø 270	2012	270	140	190	110	32	11.8	8.5	2.5	6	9.5
MSM T.L. Ø 340	2517	340	170	240	125	45	17.8	9.5	2.5	8	11.5
MSM T.L. Ø 430	3020	430	220	300	160	51	18.8	13.5	2.5	8	13.5
(*)MSM T.L. Ø 485	3020	485	250	340	160	51	18.8	13.5	2.5	8	13.5

CLAMPING ELEMENTS

The clamping system connects one or two component parts solidly to the drive shaft, which allow motion to be transmitted or to withstand an axial thrust. Friction connection enables gaps to be eliminated, thereby ensuring greater precision of the keyed components without requiring strict processing tolerances. The thrust cones develop a pressure between the shaft and the hub, which enables pulleys, gears, chain sprockets, drums, flywheels, etc. to be anchored securely. The easy assembly and disassembly features give users many advantages leading to a further cost saving.

Chiaravalli Trasmissioni S.p.A. provides its Customers with different types of clamping elements, which are designed to cover a broad range of applications.

SELF-CENTRING RCK 15 TYPE



Suitable for assemblies where axial and radial positioning accuracy is required with medium-high torque values. The main feature is the possibility of varying the internal bores while maintaining the external dimensions constant at only three diameters.

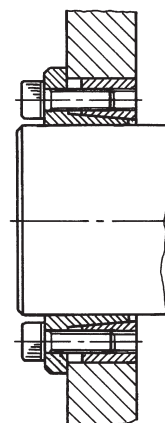

SELF-CENTRING RCK 13 TYPE



Suitable for assemblies where good concentricity is required in small spaces with medium-high torque values. Can substitute RCK 40 in some cases.

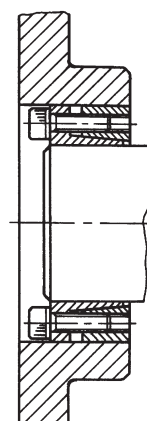

SELF-CENTRING RCK 16 TYPE



Suitable for assemblies where concentricity and positioning accuracy is required. Operates with medium-high torque values.

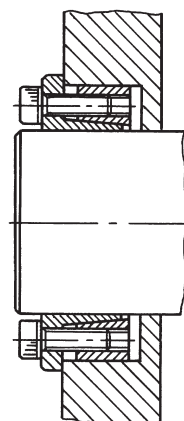

SELF-CENTRING RCK 70/71 TYPE (RCK 70 WITH SPACER)



The RCK 70 version is suitable for assemblies where concentricity and orthogonal positioning of the parts is required.

The RCK 71 version has the same features as RCK 70 with the addition of a spacer ring to completely avoid possible axial displacements.

These components operate with medium-high torque values.

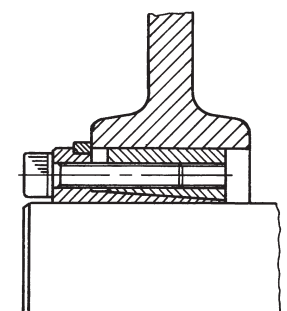

SELF-CENTRING RCK 80 TYPE



Suitable for assemblies on hubs with thin walls guarantees both axial and radial positioning precision with medium transmission torque values.

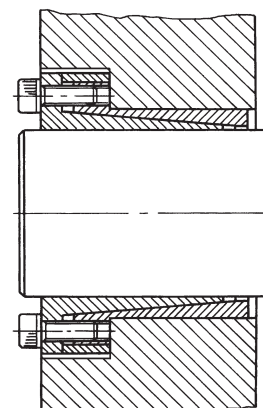

SELF-CENTRING RCK 11 TYPE



Suitable for assemblies where special, even heavy-duty conditions are required, achieving maximum friction clamping results. Incorporates the best features of all the models presented. Operates with very high torque values.

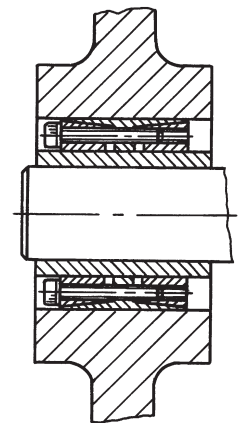

SELF-CENTRING RCK 55 TYPE



Suitable for assemblies where limited overall dimensions and times are required. Operates with medium-low torque values.

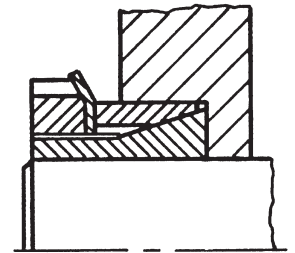

SELF-CENTRING RCK 60 TYPE



Suitable for assemblies where a medium-high twisting moment is required. Operates in the opposite mode to RCK 13.

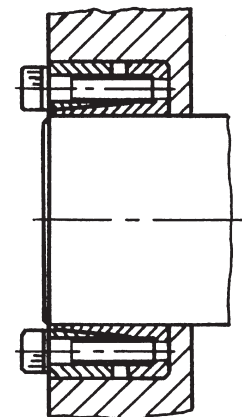

SELF-CENTRING RCK 61 TYPE

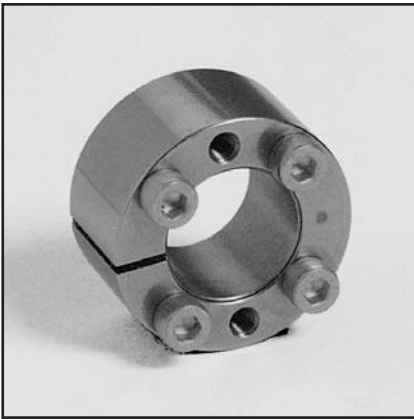

Enables adjacent components to be clamped to the hub thanks to an axial force achieved during the clamping phase.
Operates with medium torque values.

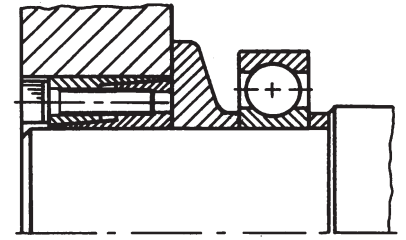

RCK 40 TYPE



Suitable for general applications, is not self-centring and therefore requires a centring band to ensure perfect concentricity.
Operates with medium-high torque values.

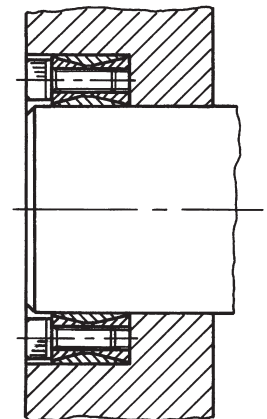

RCK 50 TYPE



Comprising two tapered rings, must always be mounted with a tightening flange.
Operates with low torque values; not self-centring.

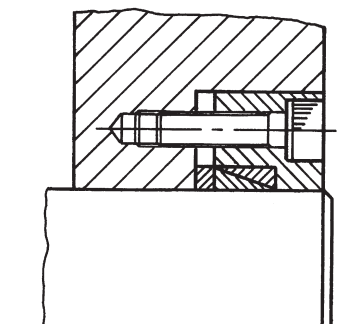

RCK 19 TYPE

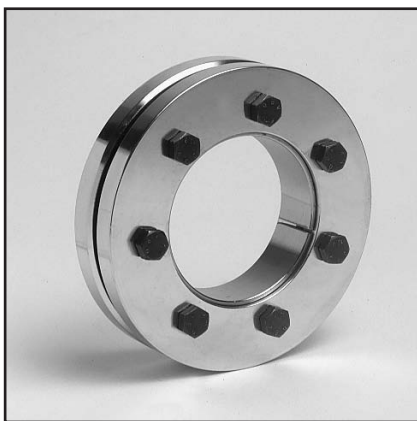

Suitable for hollow shafts, operates by compressing the hollow shafts on the solid shaft enabling transmission of medium-high twisting moments to be achieved.

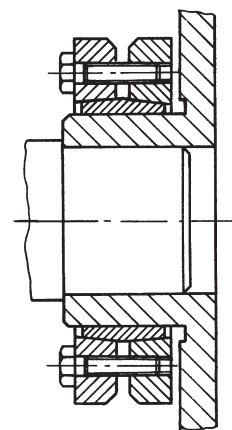

RCK 95 TYPE

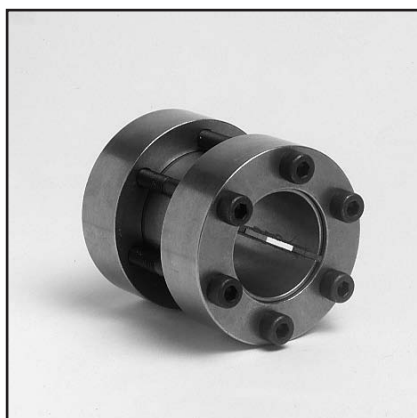

Enables rigid connection between two aligned shafts. Transmits medium-high twisting moments with the advantage of enabling rapid assembly and disassembly.

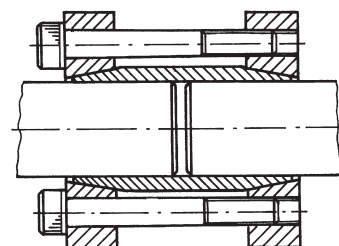

RCK 45 TYPE



Suitable for applications where medium-low twisting moments are required, with easy rapid assembly and disassembly. Not self-centring.

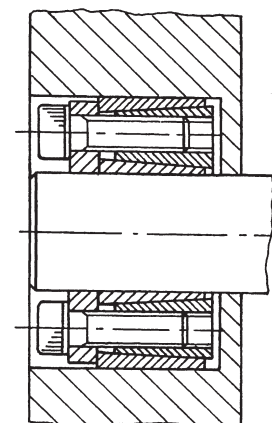

SELF-CENTRING TYPE CLAMPING

RCK 15 ELEMENTS

N.B. The recommended machining tolerances for the pressure surfaces are as follows:

h8 for Shaft

H8 for Hub

ORDERING EXAMPLE:

The following will be ordered with a shaft having $\varnothing d$ 40 with a torque value less than or equal to 1.030 Nm: **RCK 15 - 40x65.**

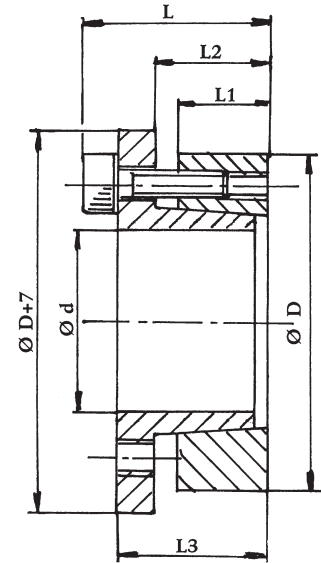

RCK 15

DIMENSIONS						PRESSURES			Clamping Screws DIN 912 MAT. 12.9			Extraction Thread	
$\varnothing d$	$\varnothing D$	L1	L2	L3	L	Torque Mt Nm	Shaft N/mm ²	Hub N/mm ²	No.	Type	Torque Nm	Type	No.
14	55	17	22	31	39	290	458	118	4	M8x25	41	M8	2
16	55	17	22	31	39	320	400	118	4	M8x25	41	M8	2
18	55	17	22	31	39	360	356	118	4	M8x25	41	M8	2
19	55	17	22	31	39	380	337	118	4	M8x25	41	M8	2
20	55	17	22	31	39	400	320	118	4	M8x25	41	M8	2
22	55	17	22	31	39	440	290	118	4	M8x25	41	M8	2
24	55	17	22	31	39	480	265	118	4	M8x25	41	M8	2
25	55	17	22	31	39	500	255	118	4	M8x25	41	M8	2
28	55	17	22	31	39	560	228	118	4	M8x25	41	M8	2
30	55	17	22	31	39	600	213	118	4	M8x25	41	M8	2
24	65	17	22	31	39	620	332	122	5	M8x25	41	M8	3
25	65	17	22	31	39	640	320	122	5	M8x25	41	M8	3
28	65	17	22	31	39	720	285	122	5	M8x25	41	M8	3
30	65	17	22	31	39	770	267	122	5	M8x25	41	M8	3
32	65	17	22	31	39	820	250	122	5	M8x25	41	M8	3
33	65	17	22	31	39	850	235	122	5	M8x25	41	M8	3
35	65	17	22	31	39	900	228	122	5	M8x25	41	M8	3
38	65	17	22	31	39	980	210	122	5	M8x25	41	M8	3
40	65	17	22	31	39	1030	200	122	5	M8x25	41	M8	3
30	80	20	25	33	41	1080	315	120	7	M8x25	41	M8	3
32	80	20	25	33	41	1150	298	120	7	M8x25	41	M8	3
33	80	20	25	33	41	1200	282	120	7	M8x25	41	M8	3
35	80	20	25	33	41	1260	272	120	7	M8x25	41	M8	3
38	80	20	25	33	41	1370	250	120	7	M8x25	41	M8	3
40	80	20	25	33	41	1440	238	120	7	M8x25	41	M8	3
42	80	20	25	33	41	1510	226	120	7	M8x25	41	M8	3
45	80	20	25	33	41	1620	212	120	7	M8x25	41	M8	3
48	80	20	25	33	41	1730	198	120	7	M8x25	41	M8	3
50	80	20	25	33	41	1800	190	120	7	M8x25	41	M8	3
40	80	20	25	33	41	2150	340	169	10	M8x25	41	M8	4
45	80	20	25	33	41	2420	302	169	10	M8x25	41	M8	4
50	80	20	25	33	41	2700	272	169	10	M8x25	41	M8	4

SELF-CENTRING TYPE CLAMPING

RCK 13 ELEMENTS

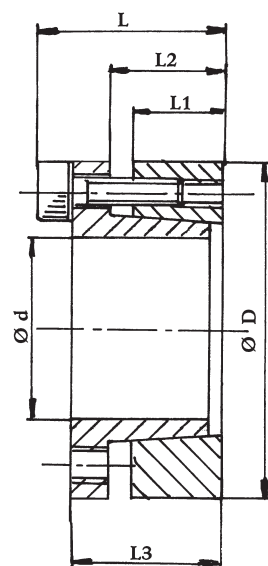

N.B. The recommended machining tolerances for the pressure surfaces are as follows:

h8 for Shaft

H8 for Hub

ORDERING EXAMPLE:

The following will be ordered with a shaft having $\varnothing d$ 30 with a torque value less than or equal to 660 Nm: **RCK 13 - 30x55.**

RCK 13

DIMENSIONS						PRESSURES			Clamping Screws DIN 912 MAT. 12.9			Extraction Thread	
$\varnothing d$	$\varnothing D$	L1	L2	L3	L	Torque Mt Nm	Shaft N/mm ²	Hub N/mm ²	No.	Type	Torque Nm	Type	No.
18	47	17	22	28	34	310	314	120	5	M6x20	14	M6	3
19	47	17	22	28	34	330	300	120	5	M6x20	14	M6	3
20	47	17	22	28	34	380	295	125	5	M6x20	14	M6	3
22	47	17	22	28	34	410	270	125	5	M6x20	14	M6	3
24	50	17	22	28	34	440	243	120	6	M6x20	14	M6	3
25	50	17	22	28	34	560	285	140	6	M6x20	14	M6	3
28	55	17	22	28	34	630	255	130	6	M6x20	14	M6	3
30	55	17	22	28	34	660	235	130	6	M6x20	14	M6	3
32	60	17	22	28	34	960	295	155	8	M6x20	14	M6	4
35	60	17	22	28	34	1050	270	155	8	M6x20	14	M6	4
38	65	17	22	28	34	1140	250	145	8	M6x20	14	M6	4
40	65	17	22	28	34	1200	235	145	8	M6x20	14	M6	4
45	75	20	25	33	41	2180	290	170	7	M8x25	35	M8	3
50	80	20	25	33	41	2430	260	160	7	M8x25	35	M8	3
55	85	20	25	33	41	3070	270	175	8	M8x25	35	M8	4
60	90	20	25	33	41	3350	245	165	8	M8x25	35	M8	4
65	95	20	25	33	41	4080	255	175	9	M8x25	35	M8	3
70	110	24	30	40	50	6280	280	180	8	M10x30	70	M10	4
75	115	24	30	40	50	6680	260	170	8	M10x30	70	M10	4
80	120	24	30	40	50	7130	250	160	8	M10x30	70	M10	4
85	125	24	30	40	50	8480	260	180	9	M10x30	70	M10	3
90	130	24	30	40	50	9080	250	170	9	M10x30	70	M10	3
95	135	24	30	40	50	10580	260	180	10	M10x30	70	M10	4
100	145	26	32	44	56	13380	270	190	8	M12x35	125	M12	4
110	155	26	32	44	56	14580	240	180	8	M12x35	125	M12	4
120	165	26	32	44	56	17880	250	180	9	M12x35	125	M12	4
130	180	34	40	52	64	29980	240	170	12	M12x35	125	M12	6
140	190	34	40	54	68	26980	210	150	9	M14x40	190	M14	4
150	200	34	40	54	68	32980	230	170	10	M14x40	190	M14	5
160	210	34	40	54	68	37980	230	170	11	M14x40	190	M14	4
170	225	44	50	64	78	44980	180	130	12	M14x40	190	M14	6
180	235	44	50	64	78	46980	170	130	12	M14x40	190	M14	6

SELF-CENTRING TYPE CLAMPING ELEMENTS RCK 16

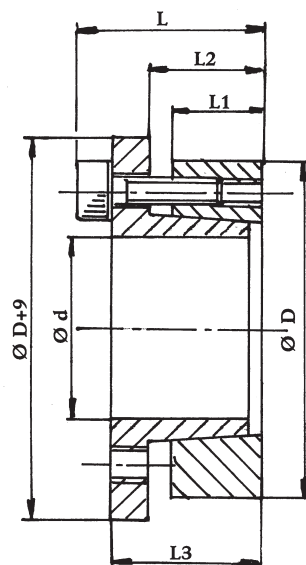

N.B. The recommended machining tolerances for the pressure surfaces are as follows:

h8 for Shaft
H8 for Hub

ORDERING EXAMPLE:

The following will be ordered with a shaft having $\varnothing d$ 75 with a torque value less than or equal to 5.000 Nm: **RCK 16 - 75x115.**

RCK 16

DIMENSIONS						Torque Mt Nm	PRESSURES		Clamping Screws DIN 912 MAT. 12.9			Extraction Thread	
$\varnothing d$	$\varnothing D$	L1	L2	L3	L		Shaft N/mm ²	Hub N/mm ²	No.	Type	Torque Nm	Type	No.
18	47	17	22	28	34	260	240	93	5	M6x20	17	M6	3
19	47	17	22	28	34	270	230	93	5	M6x20	17	M6	3
20	47	17	22	28	34	280	220	95	5	M6x20	17	M6	3
22	47	17	22	28	34	300	200	95	5	M6x20	17	M6	3
24	50	17	22	28	34	400	215	107	6	M6x20	17	M6	3
25	50	17	22	28	34	420	210	105	6	M6x20	17	M6	3
28	55	17	22	28	34	470	190	96	6	M6x20	17	M6	3
30	55	17	22	28	34	500	180	95	6	M6x20	17	M6	3
32	60	17	22	28	34	720	220	115	8	M6x20	17	M6	4
35	60	17	22	28	34	790	200	115	8	M6x20	17	M6	4
38	65	17	22	28	34	850	185	105	8	M6x20	17	M6	4
40	65	17	22	28	34	900	175	105	8	M6x20	17	M6	4
45	75	20	25	33	41	1620	215	125	7	M8x25	41	M8	3
50	80	20	25	33	41	1820	195	120	7	M8x25	41	M8	3
55	85	20	25	33	41	2300	200	130	8	M8x25	41	M8	4
60	90	20	25	33	41	2500	185	125	8	M8x25	41	M8	4
65	95	20	25	33	41	3050	190	130	9	M8x25	41	M8	3
70	110	24	30	40	50	4660	210	135	8	M10x30	83	M10	4
75	115	24	30	40	50	5000	195	125	8	M10x30	83	M10	4
80	120	24	30	40	50	5300	185	125	8	M10x30	83	M10	4
85	125	24	30	40	50	6350	195	135	9	M10x30	83	M10	3
90	130	24	30	40	50	6760	185	130	9	M10x30	83	M10	3
95	135	24	30	40	50	7900	195	135	10	M10x30	83	M10	4
100	145	26	32	44	56	9700	200	140	8	M12x35	145	M12	4
110	155	26	32	44	56	10600	180	130	8	M12x35	145	M12	4
120	165	26	32	44	56	13000	185	135	9	M12x35	145	M12	4
130	180	34	40	52	64	18900	175	125	12	M12x35	145	M12	6
140	190	34	40	54	68	20600	165	120	9	M14x40	230	M14	4
150	200	34	40	54	68	25100	175	130	10	M14x40	230	M14	5
160	210	34	40	54	68	29100	180	135	11	M14x40	230	M14	4
170	225	44	50	64	78	34100	140	105	12	M14x40	230	M14	6
180	235	44	50	64	78	36100	135	105	12	M14x40	230	M14	6

SELF-CENTRING RCK 70 TYPE CLAMPING ELEMENTS

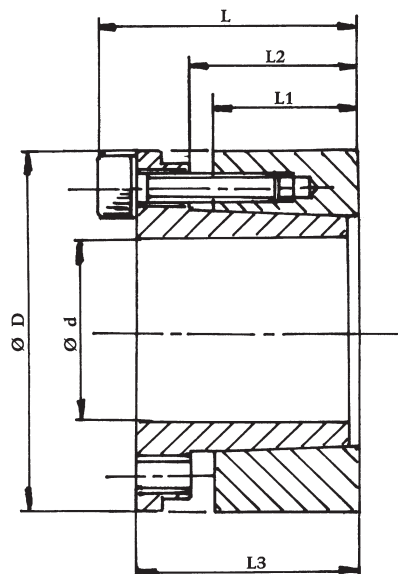

N.B. The recommended machining tolerances for the pressure surfaces are as follows:

h8 for Shaft

H8 for Hub

ORDERING EXAMPLE:

The following will be ordered with a shaft having $\varnothing d$ 48 with a torque value less than or equal to 2.510 Nm: **RCK 70 - 48x80**.

RCK 70

DIMENSIONS						PRESSURES			Clamping Screws DIN 912 MAT. 12.9			Extraction Thread	
$\varnothing d$	$\varnothing D$	L1	L2	L3	L	Torque Mt Nm	Shaft N/mm ²	Hub N/mm ²	No.	Type	Torque Nm	Type	No.
19	47	26	31	39	45	350	228	98	4	M6x25	17	M6	2
20	47	26	31	39	45	390	231	100	4	M6x25	17	M6	2
22	47	26	31	39	45	440	220	95	4	M6x25	17	M6	2
24	50	26	31	39	45	519	215	102	6	M6x25	17	M6	3
25	50	26	31	39	45	590	230	105	6	M6x25	17	M6	3
28	55	26	31	39	45	700	220	110	6	M6x25	17	M6	3
30	55	26	31	39	45	760	200	120	6	M6x25	17	M6	3
32	60	26	31	39	45	930	230	114	8	M6x25	17	M6	4
35	60	26	31	39	45	1030	200	119	8	M6x25	17	M6	4
38	65	26	31	39	45	1240	210	124	8	M6x25	17	M6	4
40	65	26	31	39	45	1350	200	125	8	M6x25	17	M6	4
42	75	30	36	47	55	2170	236	140	6	M8x30	41	M8	3
45	75	30	36	47	55	2350	236	140	6	M8x30	41	M8	3
48	80	30	36	47	55	2510	218	135	6	M8x30	41	M8	3
50	80	30	36	47	55	2580	218	135	6	M8x30	41	M8	3
55	85	30	36	47	55	3200	223	145	8	M8x30	41	M8	4
60	90	30	36	47	55	3380	198	157	8	M8x30	41	M8	4
65	95	30	36	47	55	4160	213	140	8	M8x30	41	M8	4
70	110	40	46	57	67	6840	225	143	8	M10x35	83	M10	4
75	115	40	46	62	72	7500	210	138	8	M10x35	83	M10	4
80	120	40	46	62	72	8100	200	130	8	M10x35	83	M10	4
85	125	40	46	62	72	9700	210	145	10	M10x35	83	M10	4
90	130	40	46	62	72	10300	200	138	10	M10x35	83	M10	4
95	135	40	46	62	72	12100	210	148	10	M10x35	83	M10	4
100	145	46	52	77	89	15700	216	148	8	M12x45	145	M12	4
110	155	46	52	77	89	17200	196	139	8	M12x45	145	M12	4
120	165	46	52	77	89	22500	216	156	10	M12x45	145	M12	4
130	180	46	52	77	89	24000	196	140	12	M12x45	145	M12	4
140	190	51	59	84	90	30800	196	145	8	M14x45	230	M14	4
150	200	51	59	84	90	37150	205	153	10	M14x45	230	M14	5
160	210	51	59	84	90	40500	205	155	10	M14x45	230	M14	5
170	225	51	59	84	90	40900	163	123	12	M14x45	230	M14	6
180	235	51	59	84	90	41300	160	120	12	M14x45	230	M14	6

SELF-CENTRING TYPE CLAMPING

RCK 71 ELEMENTS

(RCK 70 with spacer)

N.B. The recommended machining tolerances for the pressure surfaces are as follows:

h8 for Shaft

H8 for Hub

ORDERING EXAMPLE:

The following will be ordered with a shaft having $\varnothing d$ 30 with a torque value less than or equal to 650 Nm: **RCK 71 - 30x55**.

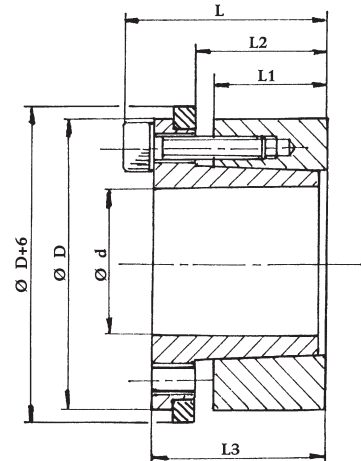

RCK 71

DIMENSIONS						Torque Mt Nm	PRESSURES		Clamping Screws DIN 912 MAT. 12.9			Extraction Thread	
Ød	ØD	L1	L2	L3	L		Shaft N/mm ²	Hub N/mm ²	No.	Type	Torque Nm	Type	No.
19	47	26	31	39	45	300	228	98	4	M6x25	17	M6	2
20	47	26	31	39	45	320	231	98	4	M6x25	17	M6	2
22	47	26	31	39	45	370	211	99	4	M6x25	17	M6	2
24	50	26	31	39	45	430	220	110	6	M6x25	17	M6	3
25	50	26	31	39	45	480	226	113	6	M6x25	17	M6	3
28	55	26	31	39	45	590	207	108	6	M6x25	17	M6	3
30	55	26	31	39	45	650	226	121	6	M6x25	17	M6	3
32	60	26	31	39	45	800	201	117	8	M6x25	17	M6	4
35	60	26	31	39	45	860	206	121	8	M6x25	17	M6	4
38	65	26	31	39	45	1030	201	124	8	M6x25	17	M6	4
40	65	26	31	39	45	1130	239	146	8	M6x25	17	M6	4
42	75	30	36	47	55	1930	221	138	6	M8x30	41	M8	3
45	75	30	36	47	55	1950	221	138	6	M8x30	41	M8	3
48	80	30	36	47	55	2180	226	145	6	M8x30	41	M8	3
50	80	30	36	47	55	2210	226	146	6	M8x30	41	M8	3
55	85	30	36	47	55	2730	226	146	8	M8x30	41	M8	4
60	90	30	36	47	55	2910	201	134	8	M8x30	41	M8	4
65	95	30	36	47	55	3570	211	145	8	M8x30	41	M8	4
70	110	40	46	57	67	5830	226	145	8	M10x35	83	M10	4
75	115	40	46	62	72	6330	221	151	8	M10x35	83	M10	4
80	120	40	46	62	72	6840	202	142	8	M10x35	83	M10	4
85	125	40	46	62	72	8160	221	161	10	M10x35	83	M10	4
90	130	40	46	62	72	8670	201	146	10	M10x35	83	M10	4
95	135	40	46	62	72	10200	191	141	10	M10x35	83	M10	4
100	145	46	52	77	89	13600	201	151	8	M12x45	145	M12	4
110	155	46	52	77	89	14870	201	182	8	M12x45	145	M12	4
120	165	46	52	77	89	19460	221	162	10	M12x45	145	M12	4
130	180	46	52	77	89	20820	202	146	12	M12x45	145	M12	4
140	190	51	59	84	90	25410	192	141	8	M14x45	230	M14	4
150	200	51	59	84	90	30720	202	152	10	M14x45	230	M14	5
160	210	51	59	84	90	33150	202	152	10	M14x45	230	M14	5
170	225	51	59	84	90	34000	161	121	12	M14x45	230	M14	6
180	235	51	59	84	90	34250	157	122	12	M14x45	230	M14	6

SELF-CENTRING TYPE CLAMPING ELEMENTS RCK 80

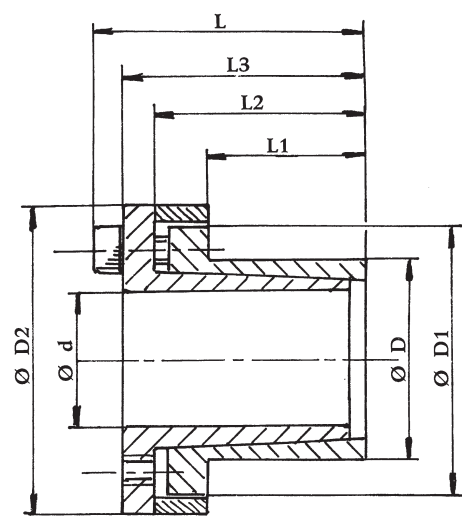

N.B. The recommended machining tolerances for the pressure surfaces are as follows:
h8 for Shaft
H8 for Hub

ORDERING EXAMPLE:
 The following will be ordered with a shaft having $\varnothing d$ 95 with a torque value less than or equal to 11000 Nm: **RCK 80 - 95x120**.

* = manufactured on request

RCK 80															
DIMENSIONS								Torque Mt Nm	PRESSURES		Clamping Screws DIN 912 MAT. 12.9			Extraction Thread	
$\varnothing d$	$\varnothing D$	$\varnothing D_1$	$\varnothing D_2$	L1	L2	L3	L		Shaft N/mm ²	Hub N/mm ²	No.	Type	Torque Nm	Type	No.
6	14	23	25	10	18.5	22.5	25.5	12	190	80	3	M3 x 10	2.2	M3	2
8	15	24	27	12	21.5	25.5	29.5	29	205	110	3	M4 x 12	5	M4	2
9	16	25	28	14	23.5	27.5	31.5	31	150	85	3	M4 x 12	5	M4	2
10	16	25	28	14	23.5	27.5	31.5	35	140	85	3	M4 x 12	5	M4	2
11	18	28	32	14	23.5	27.5	31.5	52	170	105	4	M4 x 12	5	M4	2
12	18	28	32	14	23.5	27.5	31.5	58	150	100	4	M4 x 12	5	M4	2
14	23	35	39	14	23.5	27.5	31.5	69	140	80	4	M4 x 12	5	M4	2
15	24	40	45	16	29.5	36.5	42.5	170	158	98	4	M6 x 18	17	M6	2
16	24	40	45	16	29.5	36.5	42.5	180	148	98	4	M6 x 18	17	M6	2
17	26	42	47	19	32.5	39.5	45.5	200	180	125	4	M6 x 18	17	M6	2
18	26	42	47	19	32.5	39.5	45.5	200	180	125	4	M6 x 18	17	M6	2
19	27	43	49	19	32.5	39.5	45.5	210	170	120	4	M6 x 18	17	M6	2
20	28	44	50	19	32.5	39.5	45.5	220	160	115	4	M6 x 18	17	M6	2
22	32	48	54	26	39.5	46.5	52.5	250	115	80	4	M6 x 18	17	M6	2
24	34	50	56	26	39.5	46.5	52.5	395	146	102	6	M6 x 18	17	M6	3
25	34	50	56	26	39.5	46.5	52.5	410	140	102	6	M6 x 18	17	M6	3
28	39	55	61	25.5	39.5	46.5	52.5	465	135	98	6	M6 x 18	17	M6	3
30	41	57	62	25.5	39.5	46.5	52.5	510	127	90	6	M6 x 18	17	M6	3
32	43	59	65	25.5	39.5	46.5	52.5	705	146	108	8	M6 x 18	17	M6	4
35	47	62	69	31.5	45.5	52.5	58.5	790	105	80	8	M6 x 18	17	M6	4
38	50	66	72	31.5	45.5	52.5	58.5	860	100	76	8	M6 x 18	17	M6	4
40	53	69	75	31.5	45.5	52.5	58.5	900	96	72	8	M6 x 18	17	M6	4
42	55	71	78	31.5	45.5	52.5	58.5	940	90	70	8	M6 x 18	17	M6	4
45	59	80	86	45	62.5	71	79	1840	110	85	8	M8 x 22	41	M8	4
48	62	81	87	45	62.5	71	79	2000	105	80	8	M8 x 22	41	M8	4
50	65	86	92	45	62.5	71	79	2100	100	75	8	M8 x 22	41	M8	4
55	71	92	98	55	72.5	81	89	2580	85	65	9	M8 x 22	41	M8	3
60	77	98	104	55	72.5	81	89	2800	75	60	9	M8 x 22	41	M8	3
65	84	105	111	55	72.5	81	89	3050	70	55	9	M8 x 22	41	M8	3
70	90	113	119	65	86.5	96.5	106.5	5250	90	70	9	M10 x 25	83	M10	3
75	95	119	126	65	86.5	96.5	106.5	5600	80	65	9	M10 x 25	83	M10	3
80	100	125	131	65	86.5	96.5	106.5	8000	100	80	12	M10 x 25	83	M10	4
* 85	106	131	137	65	86.5	96.5	106.5	8500	95	75	12	M10 x 25	83	M10	4
90	112	137	144	65	86.5	96.5	106.5	9000	90	75	12	M10 x 25	83	M10	4
* 95	120	142	149	65	86.5	96.5	106.5	11000	100	80	14	M10 x 25	83	M10	4
100	125	147	154	65	86.5	96.5	106.5	15000	120	95	18	M10 x 25	83	M10	4
110	140	172	180	90	114	128	140	16000	80	65	12	M12 x 35	154	M12	4
120	155	187	198	90	114	128	140	17500	70	55	12	M12 x 35	145	M12	4

SELF-CENTRING TYPE CLAMPING ELEMENTS RCK 11

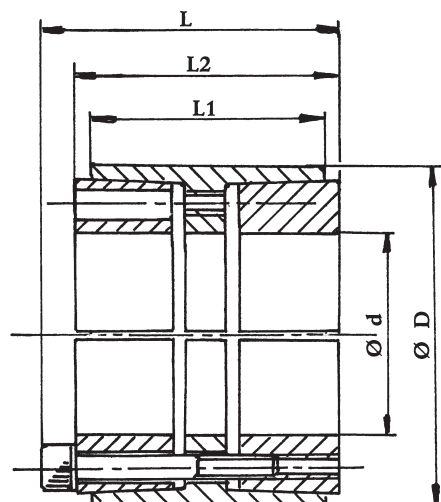

N.B. The recommended machining tolerances for the pressure surfaces are as follows:

h8 for Shaft

H8 for Hub

ORDERING EXAMPLE:

The following will be ordered with a shaft having $\varnothing d$ 45 with a torque value less than or equal to 3.200 Nm: **RCK 11 - 45x75.**

RCK 11

DIMENSIONS					Torque Mt Nm	PRESSURES		Clamping Screws DIN 912 MAT. 12.9			Extraction Thread	
$\varnothing d$	$\varnothing D$	L1	L2	L		Shaft N/mm ²	Hub N/mm ²	No.	Type	Torque Nm	Type	No.
25	55	32	40	46	840	295	134	6	M6x35	17	M6	3
28	55	32	40	46	940	264	134	6	M6x35	17	M6	3
30	55	32	40	46	1000	246	134	6	M6x35	17	M6	3
35	60	44	54	60	1360	174	101	7	M6x45	17	M6	3
38	75	44	54	62	2740	296	150	7	M8x50	41	M8	3
40	75	44	54	62	2880	281	150	7	M8x50	41	M8	3
42	75	44	54	62	3030	268	150	7	M8x50	41	M8	3
45	75	44	54	62	3240	250	150	7	M8x50	41	M8	3
48	80	44	54	62	3950	207	124	8	M8x50	41	M8	3
50	80	56	64	72	4150	200	98	8	M8x50	41	M8	3
55	85	56	64	72	5150	205	104	9	M8x50	41	M8	3
60	90	56	64	72	6200	202	106	10	M8x50	41	M8	4
65	95	56	64	72	6750	187	100	10	M8x50	41	M8	4
70	110	70	78	88	11500	223	114	10	M10x60	83	M10	4
75	115	70	78	88	12300	223	114	10	M10x60	83	M10	4
80	120	70	78	88	14500	215	115	11	M10x60	83	M10	4
85	125	70	78	88	15400	215	115	12	M10x60	83	M10	5
90	130	70	78	88	17800	208	115	12	M10x60	83	M10	5
95	135	70	78	88	18700	208	115	12	M10x60	83	M10	5
100	145	90	100	112	26300	200	107	11	M12x80	145	M12	4
110	155	90	100	112	31800	198	110	12	M12x80	145	M12	5
120	165	90	100	112	40400	212	120	14	M12x80	145	M12	5
130	180	104	116	130	51500	192	112	12	M14x90	230	M14	5
140	190	104	116	130	64700	208	124	14	M14x90	230	M14	7
150	200	104	116	130	74200	208	127	15	M14x90	230	M14	6
160	210	104	116	130	84500	208	128	16	M14x90	230	M14	7
170	225	134	148	164	108200	182	113	14	M16x110	355	M16	6
180	235	134	148	164	123250	184	115	15	M16x110	355	M16	7
190	250	134	148	164	133800	186	116	16	M16x110	355	M16	7
200	260	134	148	164	146000	177	112	16	M16x110	355	M16	7
220	285	134	148	164	181000	188	115	18	M16x110	355	M16	8
240	305	134	148	164	218000	184	119	20	M16x110	355	M16	9
260	325	134	148	164	250000	178	117	21	M16x110	355	M16	10
280	355	165	177	197	360000	185	117	18	M20x130	690	M20	8
300	375	165	177	197	428000	192	123	20	M20x130	690	M20	9

SELF-CENTRING TYPE CLAMPING

RCK 55 ELEMENTS

N.B. The recommended machining tolerances for the pressure surfaces are as follows:

h8 for Shaft

H8 for Hub

ORDERING EXAMPLE:

The following will be ordered with a shaft having $\varnothing d$ 30 with a torque value less than or equal to 270 Nm: **RCK 55 - 30x40**.

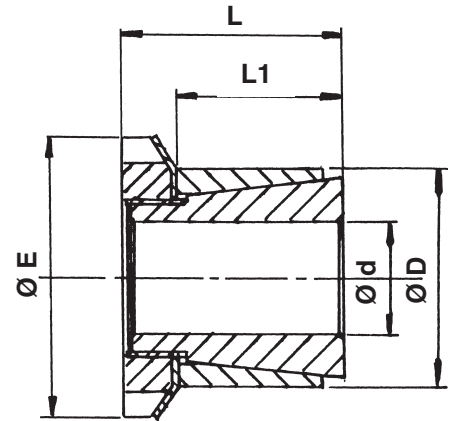

RCK 55

DIMENSIONS					Torque M _t Nm	PRESSURES		Type	Ring nut		Extraction Thread Type
Ød	ØD	ØE	L1	L		Shaft N/mm ²	Hub N/mm ²		Thread	Tightening Torque Nm	
14	25	32	23	31	65	80	45	KM4	M20x1	95	MB4
15	25	32	23	31	70	80	45	KM4	M20x1	95	MB4
18	30	38	24	33	100	75	45	KM5	M25x1.5	160	MB5
19	30	38	24	33	105	75	45	KM5	M25x1.5	160	MB5
20	30	38	24	33	112	70	45	KM5	M25x1.5	160	MB5
24	35	45	29	38	178	65	45	KM6	M30x1.5	220	MB6
25	35	45	29	38	185	60	45	KM6	M30x1.5	220	MB6
28	40	52	34	44	250	55	40	KM7	M35x1.5	340	MB7
30	40	52	34	44	270	50	40	KM7	M35x1.5	340	MB7
35	45	58	34	45	390	55	45	KM8	M40x1.5	480	MB8
40	50	65	35	46	520	55	45	KM9	M45x1.5	680	MB9
45	55	70	35	47	680	60	50	KM10	M50x1.5	870	MB 10
50	60	75	36	48	880	60	50	KM11	M55x2	970	MB 11
55	65	80	36	48	1030	60	50	KM12	M60x2	970	MB 12
60	70	85	36	50	1360	65	55	KM13	M65x2	1300	MB 13

SELF-CENTRING TYPE CLAMPING ELEMENTS RCK 60

N.B. The recommended machining tolerances for the pressure surfaces are as follows:

h8 for Shaft

H8 for Hub

ORDERING EXAMPLE:

The following will be ordered with a shaft having $\varnothing d$ 30 with a torque value less than or equal to 480 Nm: **RCK 60 - 30x55**.

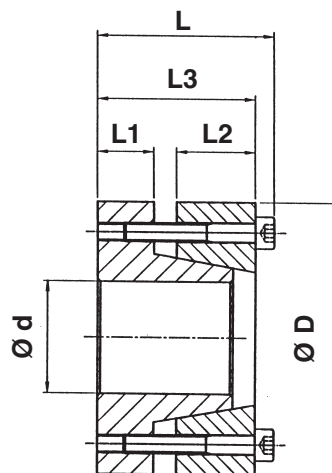

RCK 60

$\varnothing d$	$\varnothing D$	DIMENSIONS				Torque Mt Nm	Axial force N	PRESSURES		Clamping Screws DIN 912 MAT. 12.9			Extraction Thread	
		L1	L2	L3	L			Shaft N/mm ²	Hub N/mm ²	No.	Type	Torque Nm	Type	No.
20	47	10	14	28	34	245	29400	210	93	5	M6x25	17	M6	3
22	47	10	14	28	34	265	30000	196	93	5	M6x25	17	M6	3
24	50	10	14	28	34	370	32300	215	108	6	M6x25	17	M6	3
25	50	10	14	28	34	390	33300	210	108	6	M6x25	17	M6	3
30	55	10	14	28	34	480	41200	186	98	6	M6x25	17	M6	3
35	60	10	14	28	34	735	44100	186	108	8	M6x25	17	M6	4
38	65	10	14	28	34	790	46100	206	103	8	M6x25	17	M6	4
40	65	10	14	28	34	830	47000	186	103	8	M6x25	17	M6	4
42	75	12	18	35	43	1450	66000	225	132	7	M8x30	41	M8	4
45	75	12	18	35	43	1560	70000	220	132	7	M8x30	41	M8	4
50	80	12	18	35	43	1650	72000	206	127	7	M8x30	41	M8	4
55	85	12	18	35	43	2250	80000	210	132	8	M8x30	41	M8	4
60	90	12	18	35	43	2450	83000	186	122	8	M8x30	41	M8	4
65	95	12	18	35	43	2890	90000	200	132	9	M8x30	41	M8	3
70	110	16	24	46	56	4700	130000	220	140	8	M10x40	83	M10	4

SELF-CENTRING TYPE CLAMPING ELEMENTS RCK 61

N.B. The recommended machining tolerances for the pressure surfaces are as follows:

h8 for Shaft

H8 for Hub

ORDERING EXAMPLE:

The following will be ordered with a shaft having $\varnothing d$ 15 with a torque value less than or equal to 40 Nm: **RCK 61 - 15x28**.

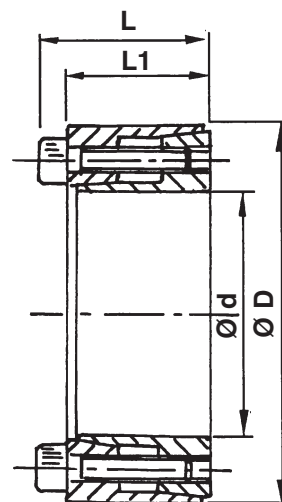

RCK 61

RCK 61													
DIMENSIONS				Torque		PRESSURES		Clamping Screws DIN 912 MAT. 12.9			Extraction Thread		
$\varnothing d$	$\varnothing D$	L1	L	Mt Nm	Shaft N/mm ²	Hub N/mm ²	No.	Type	Torque Nm	Type	No.		
10	20	13	15.5	15	110	55	4	M2.5x12	1.2	M2.5	2		
12	22	13	15.5	20	90	50	4	M2.5x12	1.2	M2.5	2		
14	26	17	20	35	105	55	4	M3x16	2.1	M3	2		
15	28	17	20	40	100	50	4	M3x16	2.1	M3	2		
16	32	17	21	70	130	65	4	M4x16	4.9	M4	2		
18	35	21	25	80	115	60	4	M4x20	4.9	M4	2		
19	35	21	25	85	110	60	4	M4x20	4.9	M4	2		
20	38	21	26	220	220	115	6	M5x20	9.7	M5	3		
22	40	21	26	240	200	110	6	M5x20	9.7	M5	3		
24	47	26	32	380	220	110	6	M6x25	16.2	M6	3		
25	47	26	32	390	210	110	6	M6x25	16.2	M6	3		

RCK 40 TYPE CLAMPING ELEMENTS

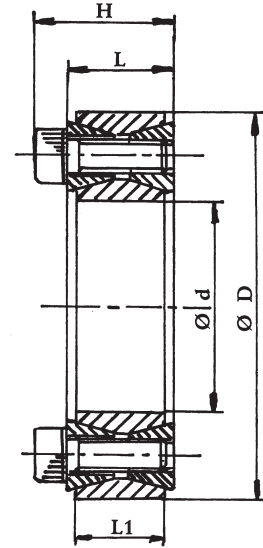

N.B. The recommended machining tolerances for the pressure surfaces are as follows:

h 9 for Shaft

H 9 for Hub

ORDERING EXAMPLE:

The following will be ordered with a shaft having $\varnothing d$ 75 with a torque value less than or equal to 4.900 Nm: **RCK 40 - 75x115**.

RCK 40

DIMENSIONS					Torque Mt Nm	PRESSURES		Clamping Screws DIN 912 MAT. 12.9			Extraction Thread	
$\varnothing d$	$\varnothing D$	L1	L	H		Shaft N/mm ²	Hub N/mm ²	No.	Type	Torque Nm	Type	No.
19	47	17	20	28	255	220	90	8	M6x18	14	M8	2
20	47	17	20	28	270	210	90	8	M6x18	14	M8	2
22	47	17	20	28	300	195	90	8	M6x18	14	M8	2
24	50	17	20	28	360	195	95	9	M6x18	14	M8	3
25	50	17	20	28	380	190	95	9	M6x18	14	M8	3
28	55	17	20	28	500	187	96	10	M6x18	14	M8	4
30	55	17	20	28	530	176	96	10	M6x18	14	M8	4
32	60	17	20	28	630	192	105	12	M6x18	14	M8	4
35	60	17	20	28	700	180	105	12	M6x18	14	M8	4
38	65	17	20	28	860	183	107	14	M6x18	14	M8	4
40	65	17	20	28	910	180	110	14	M6x18	14	M8	4
42	75	20	24	34	1500	226	125	12	M8X22	35	M10	4
45	75	20	24	34	1610	210	125	12	M8X22	35	M10	4
48	80	20	24	34	1700	196	115	12	M8X22	35	M10	4
50	80	20	24	34	1770	190	115	12	M8X22	35	M10	4
55	85	20	24	34	2270	200	130	14	M8X22	35	M10	4
60	90	20	24	34	2470	180	120	14	M8X22	35	M10	4
65	95	20	24	34	3040	190	130	16	M8X22	35	M12	4
70	110	24	28	40	4600	210	130	14	M10x25	70	M12	4
75	115	24	28	40	4900	195	125	14	M10x25	70	M12	4
80	120	24	28	40	5200	180	120	14	M10x25	70	M12	4
85	125	24	28	40	6300	195	130	16	M10x25	70	M12	4
90	130	24	28	40	6600	180	125	16	M10x25	70	M12	4
95	135	24	28	40	7900	195	135	18	M10x25	70	M12	4
100	145	26	33	47	9600	195	135	14	M12x30	125	M14	4
110	155	26	33	47	10500	180	125	14	M12x30	125	M14	4
120	165	26	33	47	13100	185	135	16	M12x30	125	M14	4
130	180	34	38	52	17600	165	115	20	M12x35	125	M14	4
140	190	34	38	52	20900	165	125	22	M12x35	125	M14	4
150	200	34	38	52	24200	170	125	24	M12x35	125	M14	4
160	210	34	38	52	28000	170	130	26	M12x35	125	M14	4
170	225	38	44	60	32800	160	120	22	M14x40	190	M16	4
180	235	38	44	60	37800	165	125	24	M14x40	190	M16	4
190	250	46	52	68	46500	150	115	28	M14x45	190	M16	4
200	260	46	52	68	52500	150	115	30	M14x45	190	M16	5
220	285	50	56	74	68000	150	115	26	M16x50	295	M18	3

RCK 50 TYPE CLAMPING ELEMENTS

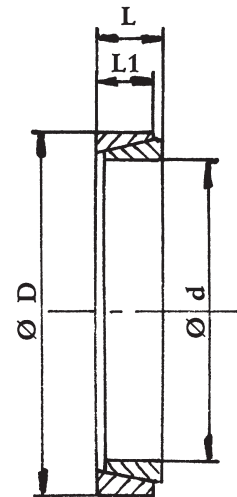

N.B. The recommended machining tolerances for the pressure surfaces are as follows:

Up to Ød 38 mm: h 6 for Shaft - H 7 for Hub

Greater than Ød 40 mm: h 8 for Shaft - H 8 for Hub

ORDERING EXAMPLE:

The following will be ordered with a shaft having Ød 24 with a torque value less than or equal to 73 Nm: **RCK 50 - 24x28.**

*Slitting

RCK 50								
Ød	DIMENSIONS			Necessary force Kg	Torque Mt Nm	PRESSURES		
	ØD	L1	L			Shaft N/mm ²	Hub N/mm ²	
*6	9	3.7	4.5	380	2.4	115	75	
*7	10	3.7	4.5	390	3	105	70	
*8	11	3.7	4.5	530	4.7	120	90	
9	12	3.7	4.5	1560	7.9	140	105	
10	13	3.7	4.5	1560	9.5	135	105	
12	15	3.7	4.5	1560	11.4	115	90	
13	16	3.7	4.5	1560	13.1	110	90	
14	18	5.3	6.3	2540	22.3	115	90	
15	19	5.3	6.3	2540	24.3	110	85	
16	20	5.3	6.3	2540	27.3	105	85	
17	21	5.3	6.3	2540	29.8	105	85	
18	22	5.3	6.3	2540	32.4	100	80	
19	24	5.3	6.3	3600	49	140	110	
20	25	5.3	6.3	3600	53	135	105	
22	26	5.3	6.3	3600	66	135	115	
24	28	5.3	6.3	3600	73	130	110	
25	30	5.3	6.3	3600	72	115	95	
28	32	5.3	6.3	3600	86	115	100	
30	35	5.3	6.3	3600	91	100	85	
32	36	5.3	6.3	4500	131	130	115	
35	40	6	7	5400	171	125	110	
36	42	6	7	5400	169	115	100	
38	44	6	7	5400	181	110	95	
40	45	6.6	8	6600	231	115	105	
42	48	6.6	8	6600	235	110	95	
45	52	8.6	10	9900	353	105	95	
48	55	8.6	10	13200	572	155	135	
50	57	8.6	10	13200	602	150	130	
55	62	8.6	10	13200	670	140	125	
56	64	10.4	12	15720	790	130	115	
60	68	10.4	12	15720	860	125	110	
63	71	10.4	12	15720	910	120	105	
65	73	10.4	12	15720	950	115	100	
70	79	12.2	14	20960	1380	125	110	
75	84	12.2	14	20960	1450	115	100	
80	91	15	17	29000	2200	125	105	

RCK 19 STANDARD TYPE CLAMPING ELEMENTS

N.B. The recommended machining tolerances for the pressure surfaces are as follows:

Diameter d h 8

IMPORTANT:

The internal cones are lubricated using products based on Molybdenum Bisulphide.

ORDERING EXAMPLE:

The following will be ordered with a shaft having $\varnothing d$ 36 with a torque value less than or equal to 440 Nm: RCK 19 - 36x72.

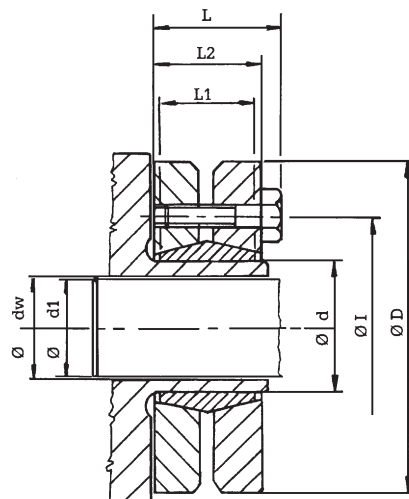

RCK 19

DIMENSIONS								PRESSURES		Clamping Screws DIN 912 MAT. 12.9		
$\varnothing d$	$\varnothing D$	$\varnothing dw$	L1	L2	L	$\varnothing I$	Δdw ($dw-d1$)	Torque Mt Nm	Shaft N/mm ²	No.	Type	Torque Nm
24	50	19	14	19.5	23	36	0.017	170	286	6	M5x18 DIN 912 Mat. 12.9	4
		20						210				
30	60	21	16	21.5	25	44	0.017	250	233	7	M5x18 DIN 912 Mat. 12.9	4
		24						300				
		25						340				
36	72	26	18	23.5	27.5	52	0.032	380	307	5	M6x20	12
		28						440				
		30						570				
		31						630				
44	80	32	20	25.5	29.5	61	0.032	620	317	7	M6x20	12
		35						780				
		36						860				
50	90	38	22	27.5	31.5	70	0.032	940	289	8	M6x25	12
		40						1160				
		42						1380				
55	100	42	23	30.5	34.5	75	0.032	1160	252	8	M6x25	12
		45						1520				
		48						1880				
		50						2200				
62	110	50	23	30.5	34.5	86	0.048	2400	279	10	M6x25	12
		52						2000				
		55						2500				
		60						3150				
75	138	55	25	32.5	37.8	100	0.048	2500	273	7	M8x30	30
		60						3200				
		65						3950				
80	145	60	25	32.5	37.8	100	0.048	3200	256	7	M8x30	30
		65						3900				
		70						4600				
90	155	65	30	39	44.3	114	0.048	4750	271	10	M8x35	30
		70						6000				
		75						7250				
		70						6900				
100	170	70	34	44	49.3	124	0.048	7500	258	12	M8x35	30
		75						9000				
		80						10800				
		75						7200				
110	185	75	39	50	56.4	136	0.048	9000	244	9	M10x40	59
		80						10800				
		85						13000				
		90						15000				
125	215	85	42	54	60.4	160	0.069	15000	266	12	M10x40	59
		90						17600				
		95						20100				
		100						22000				
140	230	105	46	60.5	68	175	0.069	25000	264	10	M12x45	100
		110						28000				
		115						31000				
		120						35000				
155	265	125	50	64.5	72	192	0.069	39000	263	12	M12x50	100
		135						41000				
		140						45000				
		145						52000				
165	290	115	56	71	81	210	0.069	57000	277	8	M16x55	250
		120						62000				
		125						39000				
		130						36000				
175	300	125	56	71	81	220	0.079	41000	261	8	M16x55	250
		135						45000				
		140						52000				
		145						57000				
185	330	135	71	86	96	236	0.090	62000	237	10	M16x70	250
		140						57000				
		145						62000				

RCK 95 RIGID JOINT TYPE CLAMPING ELEMENTS

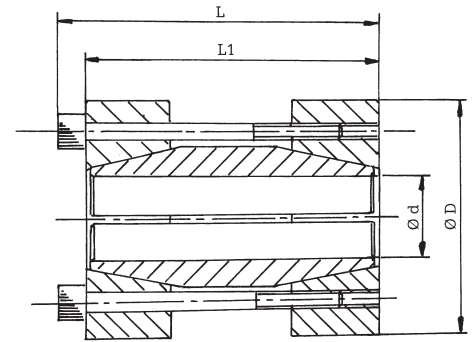

N.B. The recommended machining tolerances for the pressure surfaces are as follows:

Shaft h 8

ORDERING EXAMPLE:

The following will be ordered with a shaft having Ød 40 with a torque value less than or equal to 900 Nm: **RCK 95 - 40x75**.

* = manufactured on request

RCK 95

DIMENSIONS				Torque Mt Nm	PRESSURES		Clamping Screws DIN 912 MAT. 12.9		
Ød	ØD	L1	L		Shaft N/mm ²	No.	Type	Torque Nm	
17	50	50	56	200	110	4	M6x40	17	
18	50	50	56	220	110	4	M6x40	17	
19	50	50	56	230	110	4	M6x40	17	
20	50	50	56	240	105	4	M6x40	17	
24	55	60	66	290	120	4	M6x50	17	
25	55	60	66	450	110	6	M6x50	17	
28	60	60	66	510	110	6	M6x50	17	
30	60	60	66	550	105	6	M6x50	17	
32	63	60	66	580	90	6	M6x50	17	
35	75	75	83	790	105	4	M8x60	41	
38	75	75	83	850	100	4	M8x60	41	
40	75	75	83	900	95	4	M8x60	41	
42	78	75	83	950	90	4	M8x60	41	
45	85	85	93	1520	110	6	M8x70	41	
48	90	85	93	1620	100	6	M8x70	41	
50	90	85	93	1690	95	6	M8x70	41	
55	94	85	93	2470	110	8	M8x70	41	
60	100	85	93	2710	95	8	M8x70	41	
65	105	85	93	2930	90	8	M8x70	41	
70	115	100	110	3770	90	6	M10x80	83	
*75	125	100	110	4030	80	6	M10x80	83	
*80	125	100	110	4300	70	6	M10x80	83	

RCK 45 TYPE CLAMPING ELEMENTS

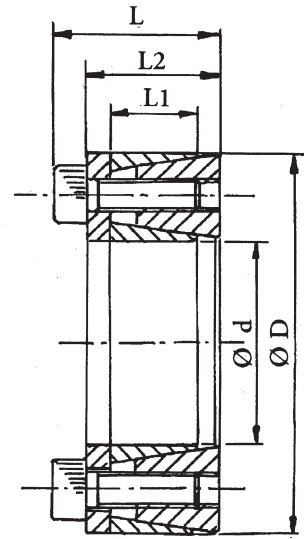

N.B. The recommended machining tolerances for the pressure surfaces are as follows:

h 8 for Shaft

H 8 for Hub

ORDERING EXAMPLE:

The following will be ordered with a shaft having $\varnothing d$ 55 with a torque value less than or equal to 2.000 Nm: **RCK 45 - 55x83.**

RCK 45

DIMENSIONS					Torque Mt Nm	PRESSURES		Clamping Screws DIN 912 MAT. 12.9			Extraction Thread	
$\varnothing d$	$\varnothing D$	L1	L2	L		Shaft N/mm ²	Hub N/mm ²	No.	Type	Torque Nm	Type	No.
18	40	12	18.5	24.5	190	260	120	6	M6X15	16	M8	2
19	41	12	18.5	24.5	210	260	120	6	M6X15	16	M8	2
20	42	12	18.5	24.5	240	250	120	6	M6X15	16	M8	2
24	46	12	18.5	24.5	290	250	120	6	M6X15	16	M8	2
25	47	12	18.5	24.5	330	230	120	8	M6X15	16	M8	2
28	50	12	18.5	24.5	370	220	120	8	M6X15	16	M8	2
30	52	12	18.5	24.5	430	210	120	8	M6X15	16	M8	2
35	57	15	22	28	610	170	100	12	M6X15	16	M8	3
38	60	15	22	28	680	170	100	12	M6X15	16	M8	3
40	62	15	22	28	780	170	100	12	M6X15	16	M8	3
42	70	18	28	36	1480	190	110	12	M8X22	41	M10	3
45	73	18	28	36	1500	210	130	12	M8X22	41	M10	3
48	76	18	28	36	1550	210	130	12	M8X22	41	M10	3
50	78	18	28	36	1650	190	120	12	M8X22	41	M10	3
55	83	18	28	36	2000	190	120	16	M8X22	41	M10	4
60	88	18	28	36	2350	190	120	16	M8X22	41	M10	4
70	105	22	35	45	3900	180	120	12	M10X25	70	M12	3
80	115	22	35	45	4800	170	120	16	M10X25	70	M12	4

CLAMPING ELEMENTS

Checking minimum hub diameter D_m

The minimum external hub diameter (D_m) must be checked after the type of clamping element with the required features has been selected, since the hub must withstand the stresses produced by the high pressures developed by the clamping element.

The check is merely static and only refers to the stresses generated by the clamping element:

$$D_m \geq D \times \sqrt{\frac{R_{s\ 0.2} + (P_m \times C)}{R_{s\ 0.2} - (P_m \times C)}}$$

- Dove:
- D_m = external hub diameter (mm)
 - D = external diameter of clamping element (mm)
 - $R_{s\ 0.2}$ = yield strength for a permanent elongation of 0.2% (N/mm²)
 - P_m = specific pressure exerted on the hub by the clamping element (N/mm²)
 - C = Utilisation coefficient depending on the hub profile (refer to the figures below).

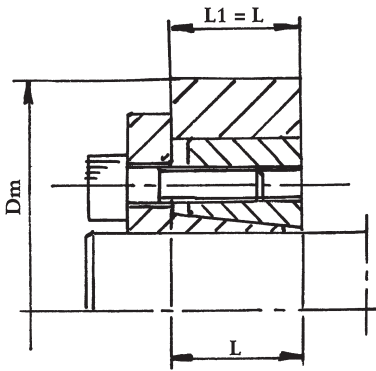

$C = 1$

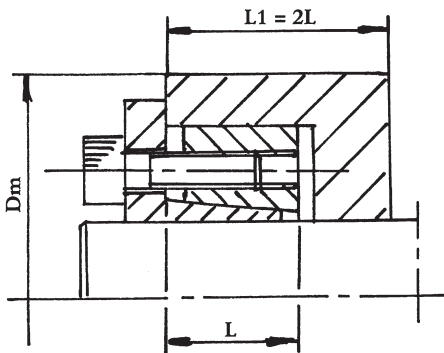
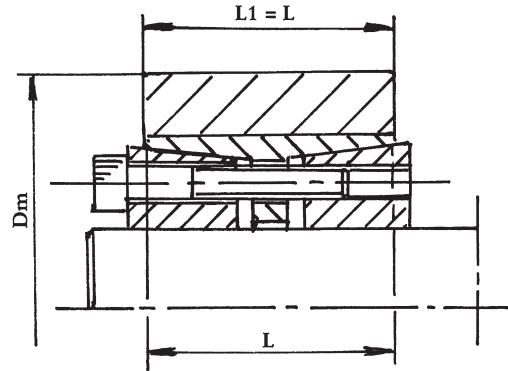

$C = 0.8$

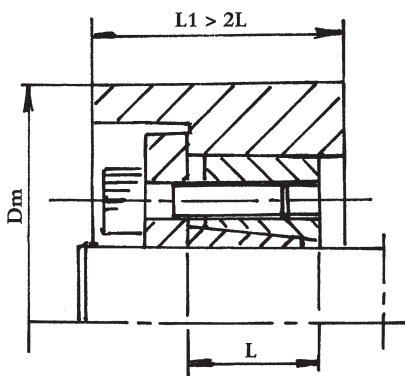
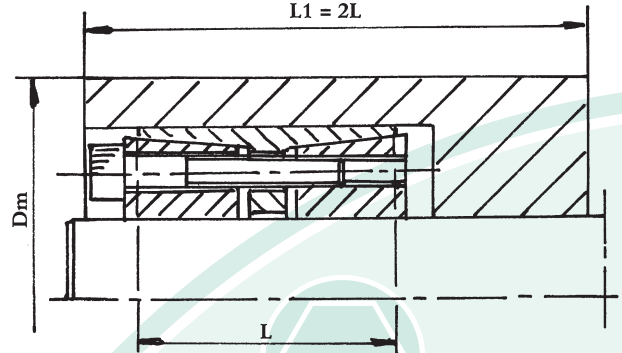

$C = 0.6$

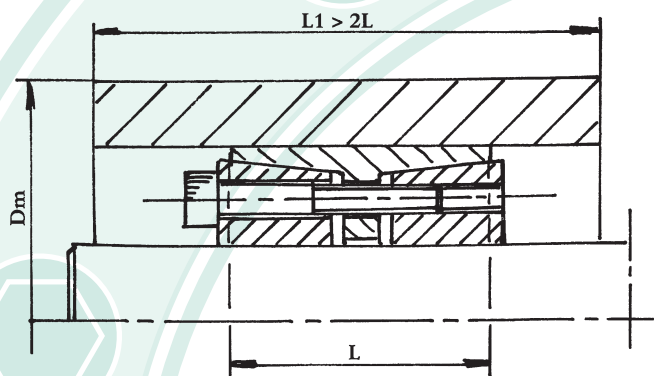

"GIFLEX®" GE-T COUPLINGS with FLEXIBLE SPIDER

TORSIONAL FLEXIBLE COUPLINGS PRECISE EXECUTION

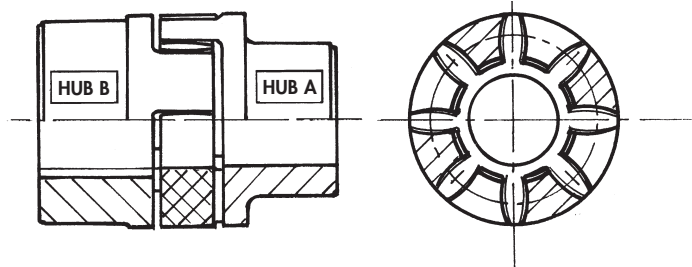

INTRODUCTION

Flexible torsion couplings, which are connecting devices between rotating shafts, are designed to ensure shock-free torque transmission and to compensate minor alignment deviations in operation between the shafts in industrial use.

The GE-T range of flexible couplings ensures this level of performance and also provides excellent quality thanks to the machining accuracy and the choice of the materials used.

The general level of reliability provided by the GE-T couplings is ensured by a satisfactory useful working life of the couplings.

GENERAL

The GE-T range of flexible couplings represents torsionally flexible, mechanical couplings capable of transmitting a twisting moment proportional to the flexible yield of the intermediate component.

The couplings must also be capable of effectively absorbing possible torsional vibrations due to the load or self-induced, to attenuate impacts and torque peaks during the start-up phase and to compensate minor angular and parallel misalignments between the shafts, however ensuring an acceptable useful working life.

These features and more in general the performance required from the coupling depend almost exclusively on the quality of the intermediate component. The choice of the material used to manufacture the coupling is therefore fundamental. The curve that expresses the flexible characteristic of the intermediate component must have a progressive trend (yielding at low torque values and remaining rigid at higher torque values) to ensure operation without jerks at start-up and with a limited torsional yield at steady state conditions.

It is essential for the intermediate component to have a certain flexible hysteresis, proportional to the required absorbing effect that ensures the coupling can effi-

ciently absorb possible torsional oscillations. Furthermore, the useful working life of the coupling depends on the flexible yield of the material comprising the intermediary component. The physical characteristics as described above are frequently in contrast with each other and compared with other basic mechanical and technological parameters. The performance of the intermediary component therefore cannot be adapted to the variety of operating conditions when only one type of material is used and therefore the materials adopted for the flexible ring gear must be differentiated. A selected thermoplastic elastomer is selected to meet medium level needs in the basic execution. This refers to an elastomer with medium rigidity, characterised by an optimum internal dampening effect, resistant to ageing, to fatigue, to abrasion, as well as hydrolysis and to the principal chemical agents with special reference to oils and ozone. Operating temperatures lying between -40°C and $+125^{\circ}\text{C}$ with brief peaks of up to 150°C are permitted in the case of couplings in the base execution. Alternative mixes capable of meeting every practical need have been designed and are available on request for use in extremely demanding operating conditions, or for needs that exceed average requirements.

OPERATING AND ASSEMBLY CONDITIONS

Operation of the flexible torsion couplings, such as the GE-T type or similar couplings is characterised by a proportional feature between the twisting torque and the torsion angle and by the ability to compensate limited angular and radial misalignments.

Key features of equal importance, but which are more difficult to interpret are represented by the absorbing factor and the natural frequency or resonance. To qualify its couplings, **CHIARAVALLI Trasmissioni spa** declares permitted twisting torque values correlated to well defined torsion angle values, which has the limiting value of 5° corresponding to the maximum torque value. This provides a valid guide for the progressive characteristic of the flexible curve. The maximum permitted values are shown in the case of the angular and radial misalignments, with the warning that these refer to extreme values that cannot be added together (only angular compensation or only radial compensation) and apply to "standard" operating conditions characterised by the following: operating torque not exceeding the nominal torque, a rotating speed of less than 1,450 r.p.m and coupling temperature not exceeding 40°C . The maximum rotating speed expressed in r.p.m. that corresponds to a maximum peripheral speed of 30 m/sec. is indicated for each coupling of the GE-T range. This speed can be achieved with a sufficient safety margin compared to the danger of failure due to centrifugal force stress thanks to the characteristics of the material used. Class G 2.5 dynamic balancing in compliance with ISO

1940 is recommended despite the fact that the half-couplings are fully machined on both external surfaces, if the actual operating speed exceeds 2.800 r.p.m.

COUPLING SELECTION AND SIZING CRITERIA

Couplings are sized on the basis of the physical laws of mechanics and the resistance of the materials and also complies with the provisions established in the DIN 740 standards Sheet 2.

The coupling is selected on the basis of the criteria, which establishes that the maximum permitted stress is never exceeded even in the most demanding operating conditions. It follows that the nominal torque declared for the coupling must be compared with a reference torque that takes into account the overloads due to the way the load is exerted and the operating conditions. The reference torque is obtained by multiplying the operating torque by a series of multiplying factors depending on the nature of the load or on the ambient temperature conditions.

Symbols:	TKN	= coupling maximum torque (Nm)	
	TK max	= coupling maximum torque (Nm)	
	TKw	= torque with coupling inversion (Nm)	
	TLN	= driven side operating torque (Nm)	
	TLs	= driven side static torque (Nm)	
	TAs	= motor side static torque (Nm)	
	Ts	= plant static torque (Nm)	
	PLn	= driven side operating power (kW)	
	nLn	= driven side rotating speed (r.p.m.)	
	St	= temperature factor	
	SA	= motor side impact factor	
	SL	= driven side impact factor	
	Sz	= start-up factor	
	MA	= control side mass factor	$\frac{JL}{JA+JL}$
	ML	= driven side mass factor	$\frac{JA}{JA+JL}$

LOAD DUE TO NOMINAL TORQUE

The permitted nominal coupling torque TKN must apply for any operating temperature value equal to or greater than the driven side operating torque TLN.

$$TLN = 9549 \frac{(PLn)}{nLn} \text{ [Nm]}$$

The following condition must be satisfied, where St represents the temperature factor, to take into account overloads due to the operating temperature for the coupling.

$$TKN = > TLN * St$$

START-UP LOAD

The drive motor delivers a drive torque during the start-up transient period, which is a multiple of the nominal torque and depends on the way the masses are distributed. A similar situation occurs in the braking phase therefore, these two phases are characterised by torque impacts that have an intensity which depends on the distribution of the masses on the drive side MA and on the driven side ML, as well as the frequency of the number of start-ups on which the start-up factor Sz depends. The static torques for the drive side and the driven side are expressed by the following relationships:

- drive side $TS = TAS * MA * SA$
- driven side $TS = TLS * MM * SL$

MA and ML are assumed to be equal to 1, to a first approximation, and if the distribution of the masses is unknown. The SA factor can be assumed as being equal to the relationship between the start-up torque and the nominal torque in the case of drives based on an electric motor.

LOAD CAUSED BY TORQUE IMPACTS

The permitted nominal coupling torque TKN max must be equal to or greater than the start-up torque increased by the temperature factor and by St and by the start-up factor Sz for any operating temperature value.

$$TKN \max > TS * St * Sz$$

Consult the CHIARAVALLI Trasmissioni Technical Department for operating conditions that foresee periodic variations or torque inversions, as well as alternate torsional stresses.

INDICATIVE VALUES FOR ADJUSTMENT FACTORS:

NAME	SYMBOL	DEFINITION				
Temperature Factor	St.	St. °C	1	1.2	1.4	1.8
			-30	+40	+80	+120
Start-up Factor	Sz.	Number of start-ups per hour				
		Start-up/hr. Sz.	100	200	400	800
Impact Factor	SA/SL	SA/SL				
		Minor start-up impacts	1.5			
		Medium start-up impacts	1.8			
		Major start-up impacts	2.2			

SERVICE FACTORS

LOAD CONDITION	OPERATING CONDITIONS	TYPE OF DRIVE	
		Electric motor	Diesel engine
UNIFORM	Regular operation without impacts or overloads	1.25	1.5
LIGHT	Regular operation with minor and infrequent impacts and overloads	1.50	2.0
MEDIUM	Irregular operation with medium overloads for a short duration and frequent but moderate impacts	2.0	2.5
HEAVY	Markedly irregular operation with very frequent impacts and overloads and of major intensity.	2.5	3.0

"GIFLEX®" G-E-T FLEXIBLE COUPLINGS

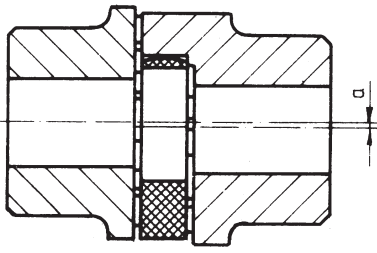

Radially displaced shafts

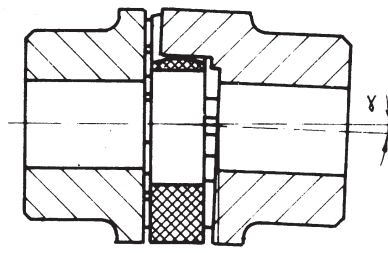

Angularly displaced shafts

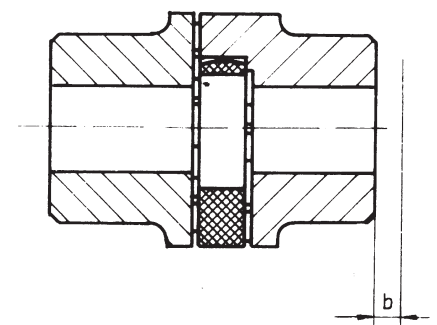

Axially displaced shafts

94 SHORE A BLACK SPIDER THERMOPLASTIC RUBBER

TECHNICAL DATA

TYPE	Max. R.p.m. n. (min ⁻¹)	Torsion Angle		Toothed Star Hardness	Twisting Moment (Nm)			Torsional Rigidity (kNm/rad)				Axial displacement b m m	Maximum misalignment	
		TKN	TKmax		TKN Norm.	MAX TKmax	TKW with Invers.	1.0 TKN	0.75 TKN	0.5 TKN	0.25 TKN		Radial α mm	Angular γ°
19/24	14000			94	10	20	2.6	0.68	0.57	0.44	0.28	1.2	0.2	1.2°
24/32	10600			94	35	70	9	2.19	1.82	1.40	0.90	1.4	0.2	0.9°
28/38	8500			94	95	190	25	5.20	4.31	3.32	2.12	1.5	0.25	0.9°
38/45	7100			94	190	380	49	10.00	8.30	6.39	4.08	1.8	0.28	1.0°
42/55	6000	3.0°	5°	94	265	530	69	17.00	14.11	10.86	6.94	2.0	0.32	1.0°
48/60	5600			94	310	620	81	20.00	16.59	12.77	8.16	2.1	0.36	1.1°
55/70	4750			94	410	820	105	21.99	18.25	14.05	8.98	2.2	0.38	1.1°
65/75	4250			94	625	1250	163	28.20	23.39	18.01	11.51	2.6	0.42	1.2°
75/90	3550			94	975	1950	254	67.99	56.41	43.44	27.75	3.0	0.48	1.2°
90/100	2800			94	2400	4800	624	110.0	91.26	70.27	44.89	3.4	0.50	1.2°

"GIFLEX®" G-E-T FLEXIBLE COUPLINGS

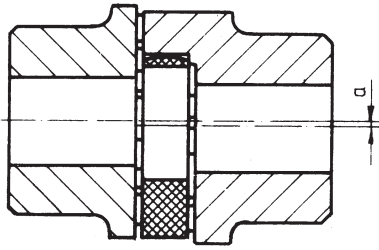

Radially displaced shafts

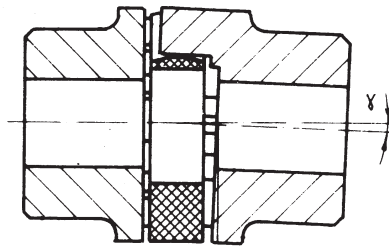

Angularly displaced shafts

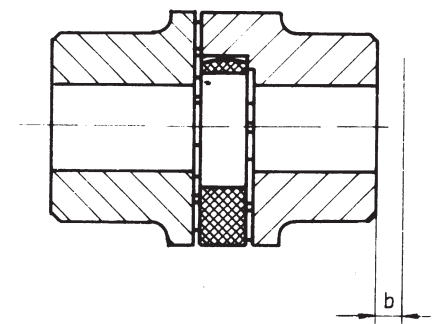

Axially displaced shafts

96 SHORE A RED SPIDER THERMOPLASTIC RUBBER
96 SHORE A YELLOW SPIDER POLYURETHANE

TECHNICAL DATA

TYPE	Max. R.p.m. n. (min ⁻¹)	Torsion Angle		Toothed Star Hardness	Twisting Moment (Nm)			Torsional Rigidity (kNm/rad)				Axial displacement b mm	Maximum misalignment	
		TKN	TKmax		TKN Norm.	MAX TKmax	TKW with Inversion	1.0 TKN	0.75 TKN	0.5 TKN	0.25 TKN		Radial α mm	Angular γ°
19/24	14000			96	17	34	4.4	1.09	0.90	0.68	0.42	1.2	0.2	1.2°
24/32	10600			96	60	120	16	3.70	3.04	2.31	1.44	1.4	0.2	0.9°
28/38	8500			96	160	320	42	9.5	7.80	5.92	3.68	1.5	0.25	0.9°
38/45	7100			96	325	650	85	29.0	23.8	18.06	11.24	1.8	0.28	1.0°
42/55	6000	3.0°	5°	96	450	900	117	40.5	33.24	25.21	15.70	2.0	0.32	1.0°
48/60	5600			96	525	1050	137	48.56	39.86	30.23	18.82	2.1	0.36	1.1°
55/70	4750			96	625	1250	163	52.78	43.32	32.86	20.46	2.2	0.38	1.1°
65/75	4250			95	640	1280	166	57.5	47.19	35.80	22.29	2.6	0.42	1.2°
75/90	3550			95	1465	2930	381	150.0	123.12	93.39	58.14	3.0	0.48	1.2°
90/100	2800			95	3600	7200	936	250.0	205.19	155.65	96.90	3.4	0.50	1.2°

"GIFLEX®" GE-T FLEXIBLE COUPLINGS

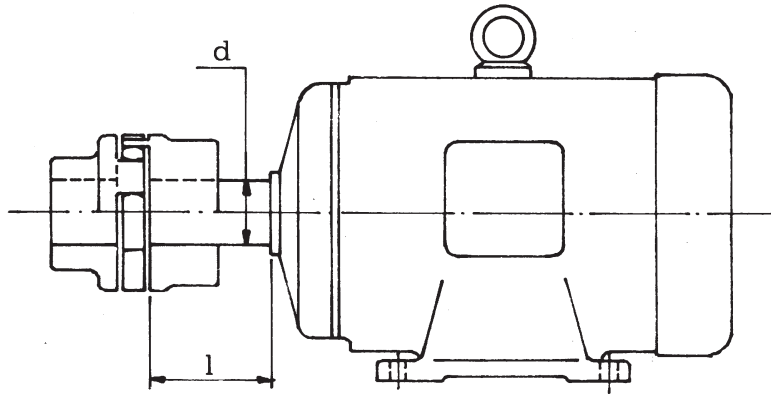

GE-T COUPLINGS designed for CEI standardised motors

ELECTRIC MOTOR TYPE	Motor power output at 50 Hz, n = 3000 min.		COUPLING		Motor power output at 50 Hz, n = 1500 min.		COUPLING		Motor power output at 50 Hz, n = 1000 min.		COUPLING		Motor power output at 50 Hz, n = 750 min.		COUPLING		Shaft end d x l (mm)
	P (kW)	T (Nm)	GE-T TYPE	Fs	P (kW)	T (Nm)	GE-T TYPE	Fs	P (kW)	T (Nm)	GE-T TYPE	Fs	P (kW)	T (Nm)	GE-T TYPE	Fs	
80	0.75	2.4		8.0	0.55	3.6		5.4	0.37	3.6		5.1	0.18	2.3		8.0	3000<1500
	1.1	3.6	19/24	5.4	0.75	4.9	19/24	3.9	0.55	5.4	19/24	3.4	0.25	3.2	19/24	5.7	19x40
90 S	1.5	4.9		4.0	1.1	7.6		2.7	0.75	7.3		2.5	0.37	4.8		3.8	24x50
90 L	2.2	7.2		2.7	1.5	9.8		2.0	1.1	10.8		5.8	0.55	7.2		2.5	
					2.2	14.4		4.7					0.75	9.8		6.4	
100 L	3	9.8		7.1					1.5	14.7		4.7					
			24/32		3	19.6	24/32	3.5			24/32		1.1	14.4	24/32	4.4	28x60
112 M	4	13.1		5.4	4	26.2		2.6	2.2	21.6		3.2	1.5	19.7		3.3	
	5.5	18.0		10.6													
132 S					5.5	36		5.3	3	29.5		6.3	2.2	28.8		6.6	
	7.5	24.6	28/38	7.6			28/38		4	39	28/38	4.8			28/38		38x80
132 M					7.5	49		3.9					3	39		4.8	
				10.6					5.5	54		3.5					
160 M	11	36			11	72		5.3	7.5	73		5.1		52		7.0	
	15	49	38/45	7.8			38/45				38/45		5.5	72	38/45	5.1	42x110
160 L	18.5	60		6.3	15	98		3.9	11	108		3.5	7.5	98		3.8	
180 M	22	72		7.5	18.5	121		4.4									48x110
180 L					22	144		3.7	15	147		3.6	11	144		3.7	
	30	98		5.5			42/55		18.5	182	42/55	2.9			42/55		
200 L					30	196		2.7					15	197		2.7	55x110
	37	121	42/55	4.4					22	216		2.5					
225 S					37	242		2.6			48/60		18.5	242	48/60	2.5	
225 M	45	147		3.7	45	295	48/60	2.1	30	295	48/60	2.1	22	288	48/60	2.1	55x110 60x140
250 M	55	180	48/60	3.5	55	360	55/70	2.1	37	364	55/70	2.1	30	394	65	2.2	60x140 65x140
280 S	75	246		3.1	75	492	75	4.0	45	442	75	4.4	37	485	75	4.0	75x140
280 M	90	295	55/70	2.6	90	590		3.4	55	541		3.6	45	591		3.3	
315 S	110	360		2.1	110	721	75/90	2.8	75	738	75/90	2.7	55	722	75/90	2.7	
315 M	132	433		4.6	132	866		2.3	90	885		2.3					65x140 80x170
	160	525		3.8	160	1030		4.7	110	1070		4.5	90	1170		4.1	
315 L			75/90				90				90				90		
	200	656		3.0	200	1290		3.7	132	1280		3.8	110	1420		3.4	
	250	820	75/90	2.4	250	1610		3.0	160	1550	90/100	3.1	132	1710	70/100	2.8	
355 L							90/100	2.4	200	1930		2.5	160	2070		3.2	75x140 95x170
	315	1010		4.8	315	2020		2.9	250	2420	100	2.7	200	2580	100	2.6	
	355	1140		4.2	355	2280											
400 L			90/100	3.8			100		315	3040							80x170 100x210
	400	1280			400	2560		2.6									

" GIFLEX® " GE-T PRECISION RANGE

Code interpretation

Example:

GE-T 19A - 24B = with hub A +hub B

GE-T 19A - 19A = with 2 hubs A

GE-T 24B - 24B = with 2 hubs B

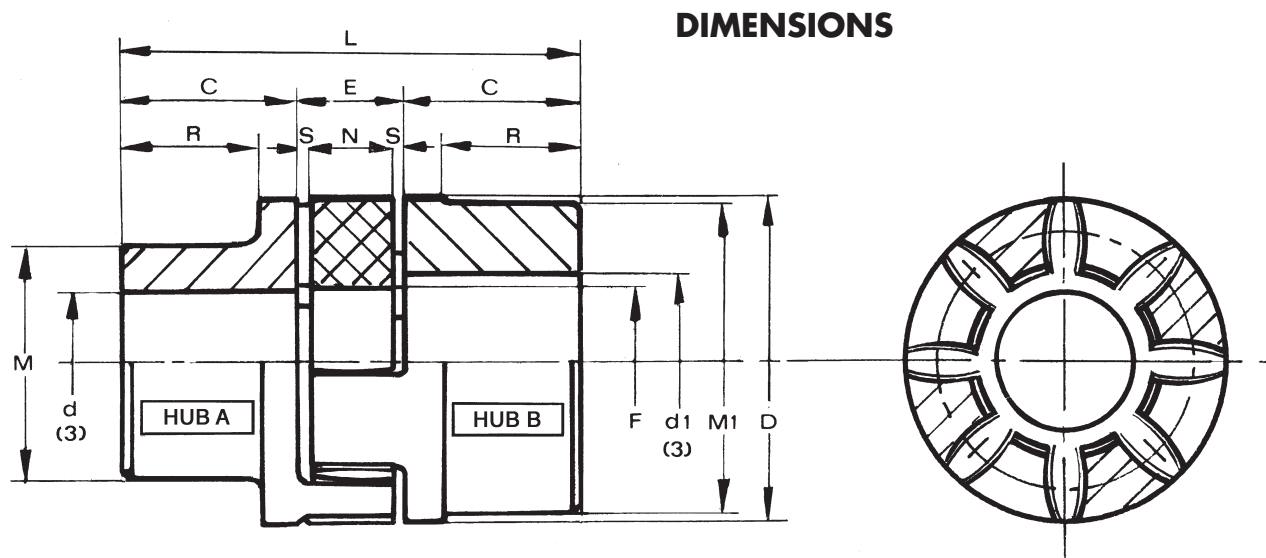

DIMENSIONS

The characteristic size of the coupling is defined by the maximum bore diameter.

Material: G25 CAST IRON * STEEL

MEASUREMENTS - WEIGHTS

COUPLING TYPE	WITHOUT BORE		Finished bore d ⁽³⁾		Measurements in mm.										Mass Kg.			J ⁽²⁾ Kg. cm ² Hubs A+B
	A	B	d max.	d1 max.	Normal range										Flexible Component	Hub A	Hub B	
					C	D	E ⁽¹⁾	F	M	M1	N	R	S	L				
GE-T 19A-24B*	-	-	19	24	25	40	16	18	30	40	12	19	2	66	0.004	0.18	0.25	0.8
GE-T 24A-32B	-	-	24	32	30	55	18	27	40	55	14	24	2	78	0.014	0.36	0.55	3
GE-T 28A-38B	-	-	28	38	35	65	20	30	48	65	15	27.5	2.5	90	0.025	0.60	0.85	7
GE-T 38A-45B	-	-	38	45	45	80	24	38	66	78	18	36.5	3	114	0.042	1.35	1.65	20
GE-T 42A-55B	-	-	42	55	50	95	26	46	75	94	20	40	3	126	0.066	2.00	2.30	50
GE-T 48A-60B	-	-	48	60	56	105	28	51	85	104	21	45	3.5	140	0.088	2.75	3.10	80
GE-T 55A-70B	-	-	55	70	65	120	30	60	98	118	22	52	4	160	0.116	4.20	4.50	160
GE-T 65A-75B	-	-	65	75	75	135	35	68	115	134	26	61	4.5	185	0.172	6.50	6.80	310
GE-T 75A-90B	-	-	75	90	85	160	40	60	135	158	30	69	5	210	0.325	10.00	10.80	680
GE-T 90A-100B	38	38	90	100	100	200	45	100	160	180	34	81	5.5	245	0.440	14.00	15.80	1590

(1) Assembly distances

(2) Coupling inertia moment with hubs A-B and max. bore \varnothing

(3) **On request:** Finished bore in compliance with ISO standards, H7 tolerance, keyway DIN 6885, sheet 1, JS9 tolerance. Dowel bore.

" GIFLEX[®] " GE-T PRECISION RANGE

EXECUTION WITH TAPER-LOCK[®] BUSH

Code interpretation

Example:

GE-T 28I - 38E = with hub I + hub E

GE-T 28I - 28I = with 2 hubs I

GE-T 38E - 38E = with 2 hubs E

DIMENSIONS

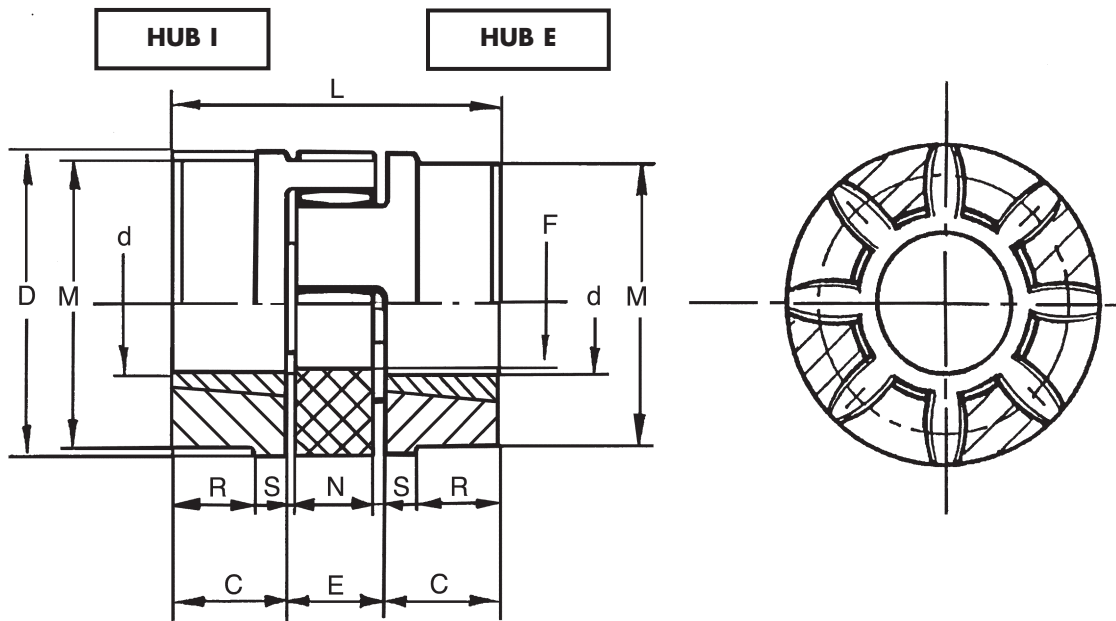

Material: G25 CAST IRON

MEASUREMENTS - WEIGHTS

COUPLING TYPE	Taper Lock Bush	Finished bore d		Measurements in mm.									Mass Kg.		
		d min.	d max.	Normal range									Flexible Component	Hubs B ₁ Max. Bore	J ⁽²⁾ Kg. cm ² Hubs B ₁
				C	D	E ⁽¹⁾	F	M	N	S	L	R			
GE-T28-38 B1-TL	1108	14	25	23	65	20	30	65	15	2.5	66		0.025	0.50	7
GE-T38-45 B1-TL	1108	14	25	23	80	24	38	78	18	3	70	15	0.042	0.88	26
GE-T42-55 B1-TL	1610	14	42	26	95	26	46	94	20	3	78	16	0.066	1.40	36
GE-T48-60 B1-TL	1615	19	40	39	105	28	51	104	21	3.5	106	28	0.088	2.33	78
GE-T55-70 B1-TL	2012	19	50	33	120	30	60	118	22	4	96	20	0.116	2.42	120
GE-T75-90 B1-TL	2517	19	65	52	160	40	80	158	30	5	144	36	0.325	6.80	630

(1) Assembly distances

(2) Coupling inertia moment with hubs I and E max. bore

"GIFLEX®" GE-T PRECISION RANGE

ALUMINIUM ALLOY EXECUTION

Code interpretation

Example:

GE-T 19A - 24B/AL = with hub A + hub B

GE-T 19A - 19A/AL = with 2 hubs A

GE-T 24B - 24B/AL = with 2 hubs B

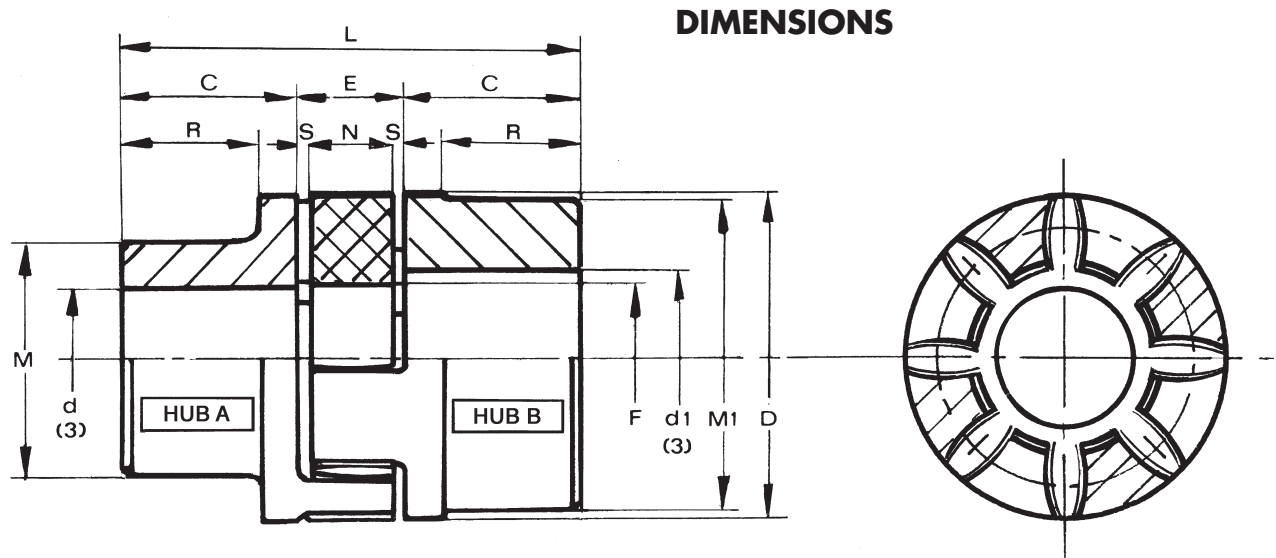

DIMENSIONS

Material: ALUMINIUM ALLOY

MEASUREMENTS - WEIGHTS

COUPLING TYPE	WITHOUT BORE		Finished bore d ⁽³⁾		Measurements in mm.										Mass Kg.			J Kg. cm ² Hubs A+B ⁽²⁾
	A	B	d max.	d1 max.	Normal range										Flexible Component	Hub A	Hub B	
					C	D	E ⁽¹⁾	F	M	M1	N	R	S	L				
GE-T 19A-24B/AL	-	10	19	24	25	40	16	18	30	40	12	19	2	66	0.005	0.07	0.08	0.4
GE-T 24A-32B/AL	8	14	24	32	30	55	18	27	40	55	14	24	2	78	0.014	0.13	0.18	1.0
GE-T 28A-38B/AL	10	16	28	38	35	65	20	30	48	65	15	27.5	2.5	90	0.025	0.22	0.30	3.0
GE-T 38A-45B/AL	12	20	38	45	45	80	24	38	66	78	18	36.5	3	114	0.042	0.48	0.55	8.0

(1) Assembly distances

(2) Coupling inertia moment with hubs A and B and max. bore Ø

(3) **On request:** Finished bore in compliance with ISO standards, H7 tolerance, keyway DIN 6885, sheet 1, JS9 tolerance. Dowel bore.

N.B.: use of a polyurethane elastomer is recommended

"GIFLEX®" GE-T SG BACKLASH-FREE TORSIONAL COUPLING

INTRODUCTION

The aluminium flexible couplings GE-T SG are made of three pre-tensioned elements in backlash-free execution.

They are meant for the coupling mounting and they are designed to fit low torque working units and industrial processing, where they must satisfy certain requirements.

Thanks to their limited dimensions and their easy mounting, they can operate in little space and any project can take big advantages of it.

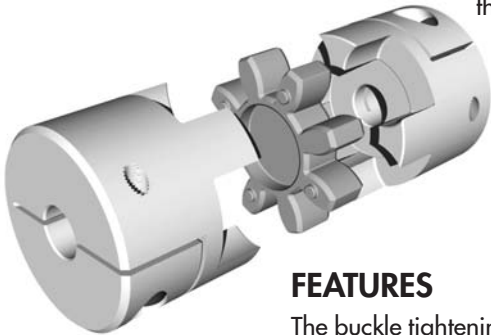

FEATURES

The buckle tightening guarantees a quick and sure fixing without extension between shaft and hub. It is however important to keep the screw tightening torque (MS) shown in the table.

Besides testing the size of the coupling given in the table, it is suggested to test the maximum torque of buckle to diameter (F).

The elastomeric element, that has a star shape, is set into the hubs' hollow seats with a light pre-tensioning, ensuring the needed transmission torque backlash-free execution.

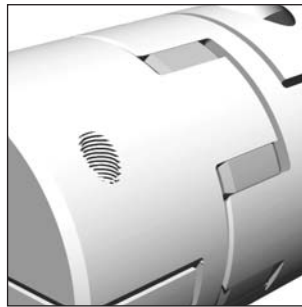
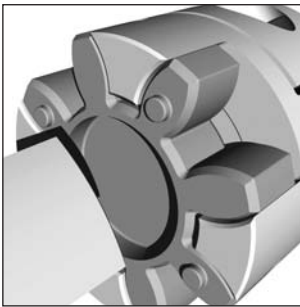

TECHNICAL DATA (Polyurethane elastomeric element in blu colour 80 shore A - in yellow colour 92 shore A - in red colour 98 shore A).

COUPLING GE-T SG	Elastomeric element hardness Shore A	N. max speed revolution V=30m/s	TORQUE (Nm)			STIFFNESS			WEIGHT		Mass inertia moment Kgm ² x 10 ⁻⁶			
			Tksg	Tkn	Tk mx	Torsion statica Nm/rad	Torsion dinam. Nm/rad	radial N/mm	Hub	Star				
9	80	28000	0,45	1,8	3,6	17,02	52	125	0,009	0,002	0,57			
	92			3,0	6,0	31,5	95	262						
	98			5,0	10,0	51,5	150	518						
14	80	19000	1,0	4,0	8,0	60,2	180	153	0,020	0,005	3,25			
	92			7,5	15,0	114,6	344	336						
	98			12,5	25,0	172,0	513	604						
19/24	80	14000	2,5	4,9	9,8	343,8	1030	582	0,066	0,007	21,90			
	92			10,0	20,0	573,0	1720	1120						
	98			17,0	34,0	859,0	2580	2010						
24/28	80	10600		17,0	34,0	1432,0	4296	1480	0,132	0,018	58,30			
	92			35,0	70,0							2063,0	6189	2560
	98			60,0	120,0									
28/38	80	8500		46,0	92,0	2292,0	6879	1780	0,253	0,029	216,80			
	92			95,0	190,0							3438,0	10315	3200
	98			160,0	320,0									
38/45	80	7100		94,0	188,0	4589,0	13752	2350	0,455	0,049	445,20			
	92			190,0	380,0							21485	4400	
	98			325,0	650,0									

N.B. FOR EXTERNAL SPEED MORE THAN V=30m/s DYNAMIC BALANCING IS NEEDED.

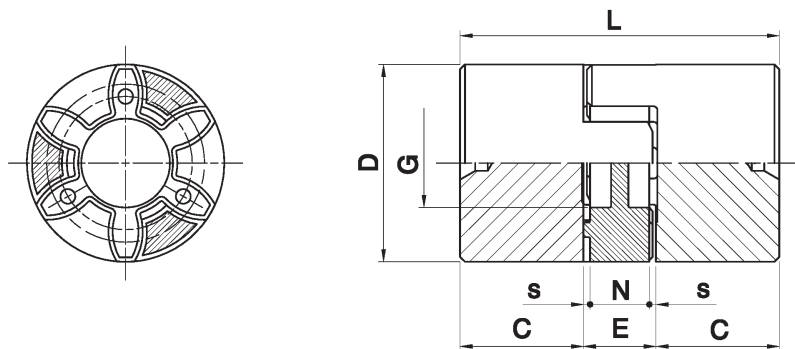

DIMENSIONS: EXECUTION A IN ALUMINIUM ALLOY WITH PLAIN HUB

COUPLING TYPE	F min.	F max	D	G	L	C	E	N	s
9	4	10	20	7,2	30	10	10	8	1,0
14	4	16	30	10,5	35	11	13	10	1,5
19/24	8	20	40	18	66	25	16	12	2,0

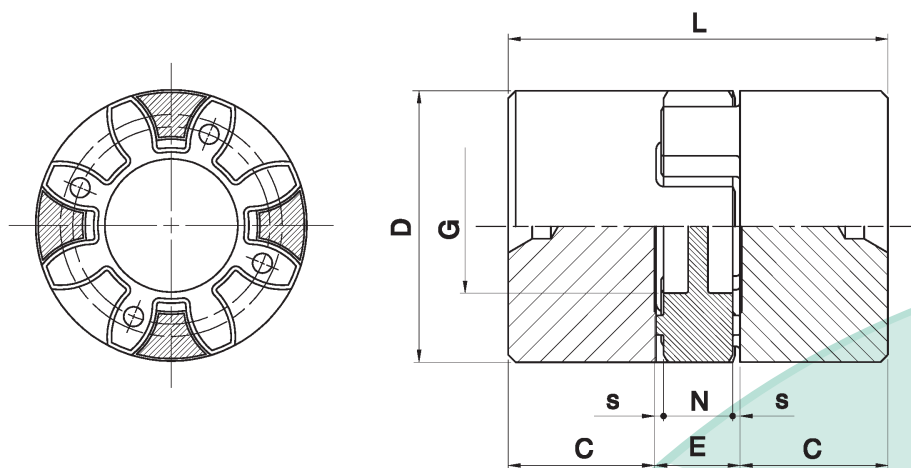

DIMENSIONS: EXECUTION B IN ALUMINIUM ALLOY WITH PLAIN HUB

COUPLING TYPE	F min.	F max	D	G	L	C	E	N	s
24/28	12	28	55	27	78	30	18	14	2,0
28/38	18	35	65	30	90	35	20	20	2,5
38/45	18	45	80	38	114	45	24	18	3,0

" GIFLEX[®] " GE-T SG

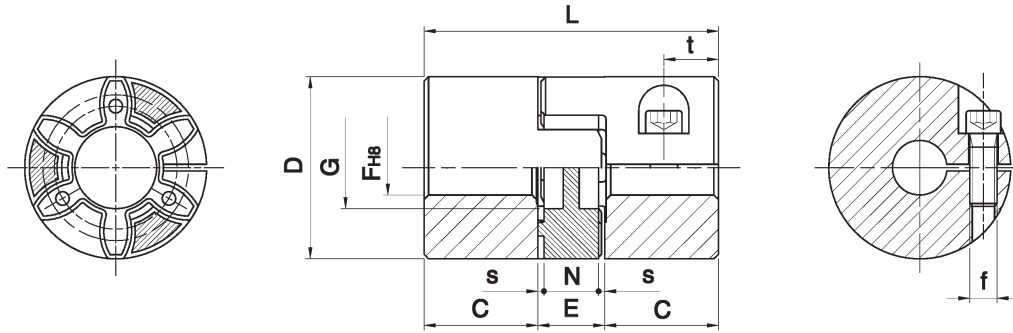

DIMENSION: EXECUTION C IN ALUMINIUM ALLOY WITH SIMPLE SPLIT

COUPLING TYPE	Execution	F min.	F max	D	G	L	C	E	N	s	f	Ms screws (Nm)	t
9	A	4	10	20	7,2	30	10	10	8	1,0	M2,5	0,75	5
14	A	4	16	30	10,5	35	11	13	10	1,5	M3	1,40	5
19/24	A	8	20	40	18	66	25	16	12	2,0	M6	11,0	12

ALLOWED TORQUE (Nm)

COUPLING TYPE	PRODUCED DIAMETER OF BORES (F)																			
	5	6	8	10	12	14	15	16	18	19	20	22	24	25	28	30	32	35	38	40
9	1,55	1,63	1,79	1,94																
14	3,32	3,43	3,67	3,91	4,14	4,38	4,5	4,6												
19/24			18	19	20	21	21,5	22	22,5	23	24									

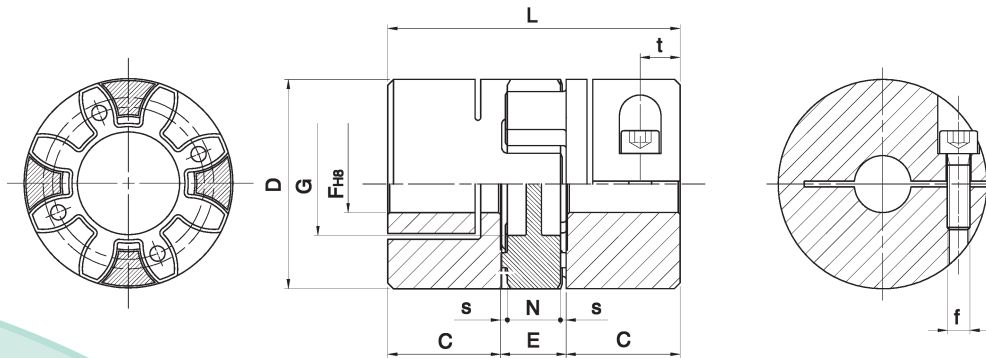

DIMENSIONS: EXECUTION D IN ALUMINIUM ALLOY WITH DOUBLE SPLIT

COUPLING TYPE	Execution	F min.	F max	D	G	L	C	E	N	s	f	Ms screws (Nm)	t
24/28	B	12	28	55	27	78	30	18	14	2,0	M6	11,0	14
28/38	B	18	35	65	30	90	35	20	15	2,5	M8	25,0	15
38/45	B	18	45	80	38	114	45	24	18	3,0	M8	25,0	20

ALLOWED TORQUE (Nm)

COUPLING TYPE	PRODUCED DIAMETER OF BORES (F)																				
	5	6	8	10	12	14	15	16	18	19	20	22	24	25	28	30	32	35	38	40	
24/28					25	26	27	27,5	28	28,5	29	30	31	32	33						
28/38								60	61	62	63	65	66	69	71	73	75				
38/45								69	70	71	73	74	78	78	80	81	84	87	88		

"GIFLEX®" GF COUPLINGS with POLYAMIDE SLEEVE

DUAL CURVATURE FLEXIBLE TOOTHED COUPLINGS

PRESENTATION

The GIFLEX range of flexible toothed couplings are commercial couplings for general applications, which are however manufactured to a high quality standard and offer technical and performance features that are typical of industrial couplings.

The specific application sector refers to power transmissions for the flexible connection of rotating parts, with the possibility of compensating radial and angular misalignments and absorbing axial slippage.

The performance is in line with this class of couplings, rendered more demanding and better suited to the needs of industrial requirements by the design criteria adopted and the precision with which the couplings are machined and systematically tested.

CONSTRUCTION

In structural terms, the flexible toothed couplings consist of two symmetrical steel hubs and a synthetic resin sleeve, which ensures the coupling and power transmission between the two hubs.

The two hubs are manufactured from low carbon content steel and have been subjected to anti-corrosion surface treatment and are each fitted with a toothed ring.

The hollow sleeve with internal toothing formed by injection moulding comprises a high molecular weight semi-crystalline technical polymer, guaranteed by certification at origin, thermally conditioned and charged with a solid lubricant that contributes to enhance the self-lubricating features typical of the polymer. The toothing of the two hubs has a progressive dual curvature, produced using a Numerically Controlled machine tool, which ensures the coupling provides optimum performance. This solution enables dynamic type angular and radial misalignments to be compensated ALSO UNDER LOAD CONDITIONS. The specific geometry of the tooth for a given transmitted twisting moment significantly reduces the surface pressure, thereby increasing the coupling's capacity to

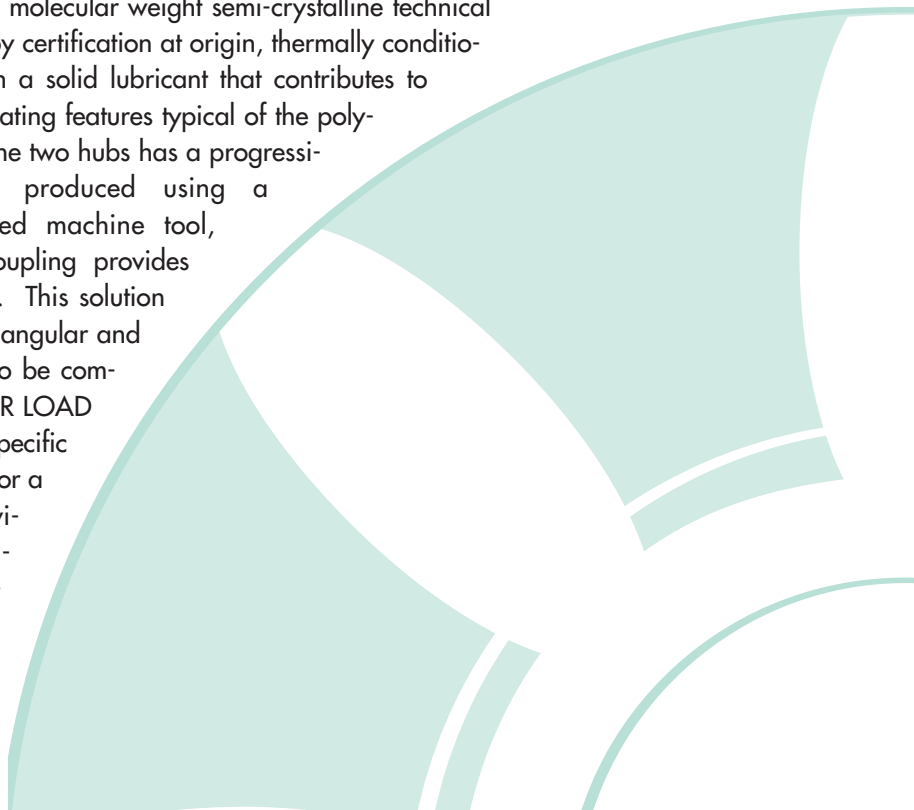

transmit the load and fatigue resistance.

The polymer's relative insensitivity to atmospheric humidity and its capacity to withstand temperatures between -20° and $+120^{\circ}$ with brief peaks of up to $+150^{\circ}$ enable the coupling to withstand demanding working conditions also in an aggressive environment.

CHARACTERISTICS

The couplings provide the following performance in practical applications:

- Reduced overall dimensions, weight and inertia moment;
- Constant velocity behaviour at speed;
- Silent operation and the ability to absorb impacts and vibrations flexibly;
- Withstand the most common aggressive chemical agents and moderate heat, max. temp. 80° ;
- Self-lubricating, electrically insulated and maintenance-free;
- Inexpensive, easily assembled and are suited to a variety of applications, also in demanding conditions.



"GIFLEX®" GF FLEXIBLE COUPLINGS

Code interpretation

Example:

GF - 14-NN = with 2 normal hubs

GF - 14-NL = with one normal hub and a long hub

GF - 14-LL = with 2 long hubs

DIMENSIONS

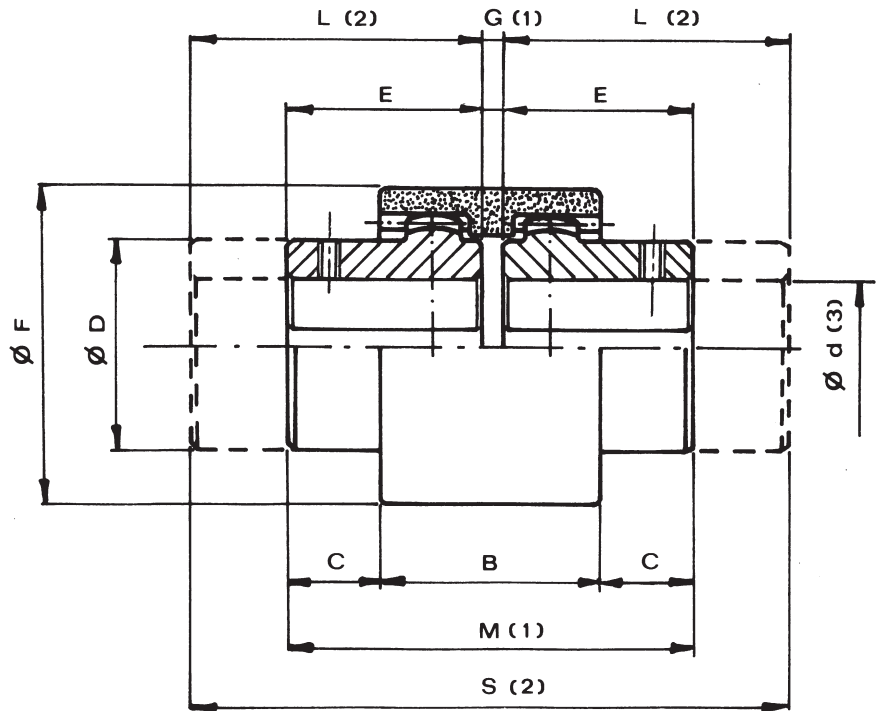

The coupling's characteristic size is defined by the maximum bore diameter.

MEASUREMENTS - WEIGHTS

COUPLING TYPE	WITHOUT BORE	Finished bore d ⁽³⁾		Measurements in mm.									Mass Kg.		
		nom.	max.	Normal range						Long Range			Sleeve	Normal Hub	Long Hub
				B	C	ØD	E	ØF	G ⁽¹⁾	M ⁽¹⁾	L ⁽²⁾	S ⁽²⁾			
GF-14	-	6	14	38	6.5	25	23.5	41	4	51	30	64	0.022	0.10	0.13
GF-19	-	8	19	38	8.5	32	25.5	48	4	55	40	84	0.028	0.18	0.28
GF-24	-	10	24	42	7.5	36	26.5	52	4	57	50	104	0.037	0.23	0.42
GF-28	-	10	28	48	19	45	41	68	4	86	60	124	0.086	0.54	0.79
GF-32	-	12	32	48	18	50	40	75	4	84	60	124	0.104	0.66	0.97
GF-38	-	14	38	50	17	58	40	85	4	84	80	164	0.131	0.93	1.83
GF-42	-	20	42	50	19	63	42	95	4	88	110	224	0.187	1.10	2.76
GF-48	-	20	48	50	27	68	50	100	4	104	110	224	0.198	1.50	3.21
GF-55	-	25	55	65	29.5	82	60	120	4	124	110	224	0.357	2.63	5.12
GF-65	-	25	65	72	36	95	70	140	4	144	140	284	0.595	4.02	7.92

(1) Assembly distances.

(2) Couplings with hub lengths to fully cover normal shafts for the UNEL-MEC range of motors.

(3) **On request:** finished bore in compliance with ISO standards, H7 tolerance, keyway DIN 6885, sheet 1, JS9 tolerance. Dowel bore.

MISALIGNMENTS

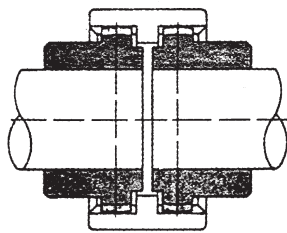

Aligned shafts

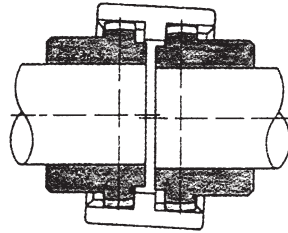

Radially displaced shafts

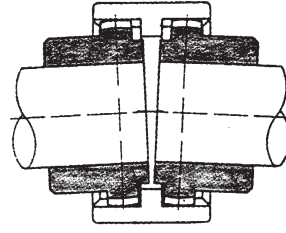

Angularly displaced shafts

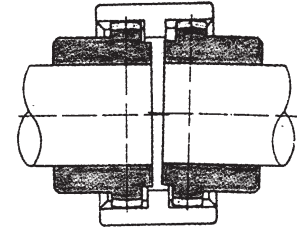

Radially and angularly displaced shafts

COUPLING SELECTION

Torque based selection: the coupling must be selected so that the max motor torque does not exceed the coupling's permitted peak twisting moment.

TECHNICAL DATA

COUPLING TYPE	POWER FACTOR KW r.p.m.		TORQUE Nm		POWER TRANSMITTED IN KW AT R.P.M.								Max. R.P.M.	Mass Kg.	J Kg cm ² ⁽¹⁾	Maximum misalignment for each hub ⁽¹⁾		Axial displacement mm.
	norm.	max.	norm.	max.	750		1000		1500		3000					Angular α ⁽²⁾	Radial mm.	
					norm.	max.	norm.	max.	norm.	max.	norm.	max.						
GF-14	0.0011	0.0023	11.5	23	0.8	1.5	1.1	2.0	1.6	3.0	3.3	6.0	14000	0.166	0.27	±2°	0.7	±1
GF-19	0.0019	0.0037	18.5	36.5	1.3	2.7	1.8	3.7	2.7	5.5	5.4	11.1	12000	0.276	0.64	±2°	0.8	±1
GF-24	0.0023	0.0047	23	46	1.7	3.5	2.3	4.7	3.4	7.0	6.9	14.1	10000	0.312	0.92	±2°	0.8	±1
GF-28	0.0053	0.0106	51.5	103.5	3.9	7.9	5.2	10.6	7.8	15.9	15.6	31.8	8000	0.779	3.45	±2°	1	±1
GF-32	0.0071	0.0142	69	138	5.2	10.5	7.0	14.1	10.5	21.1	21.0	42.3	7100	0.918	5.03	±2°	1	±1
GF-38	0.0090	0.0181	88	176	6.7	13.5	9.0	18.0	13.5	27.0	27.0	54.0	6300	1.278	9.59	±2°	0.9	±1
GF-42	0.0113	0.0226	110	220	8.4	16.8	11.2	22.5	16.8	33.7	33.6	67.5	6000	1.473	13.06	±2°	0.9	±1
GF-48	0.0158	0.0317	154	308	11.8	23.6	15.8	31.6	23.7	47.4	47.4	94.8	5600	1.777	18.15	±2°	0.9	±1
GF-55	0.029	0.058	285	570	21.7	43.5	29.0	58.0	43.5	87.0	87.0	174.0	4800	3.380	49.44	±2°	1.2	±1
GF-65	0.0432	0.0865	420	840	32.1	64.3	42.9	85.8	64.3	128.7	128.7	257.4	4000	4.988	106.34	±2°	1.3	±1

(1) Normal coupling reference complete with maximum bore without keyway.

(2) Per hub.

ASSEMBLY GUIDELINES

- Position the two semi-couplings on the shafts, taking care that the internal surfaces are in line with the shaft ends.
- Insert the sleeve on the two semi-couplings adjusting their distance (distance "G"), while the two shafts are aligned at the same time.
- Clamp the two parts to be coupled together in position.
- Check that the sleeve is free to move in an axial direction before the coupling is rotated.

"GIFLEX®" GFA-GFAS COUPLINGS with STEEL SLEEVE

DUAL CURVATURE, FLEXIBLE TOOTHED COUPLINGS

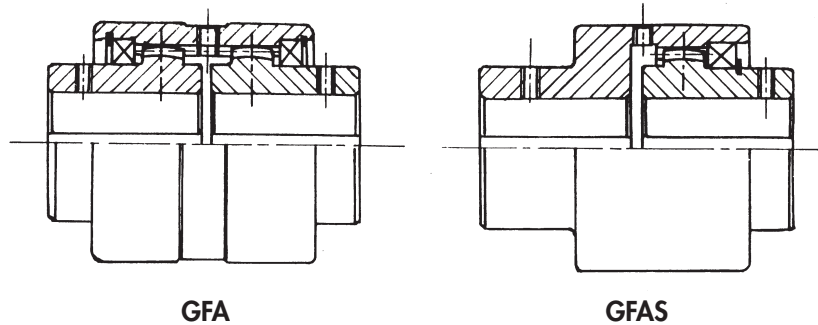

PRESENTATION

The "GIFLEX" GFA - GFAS range of flexible couplings represent couplings designed with a compact structure for industrial applications, torsionally rigid and capable of compensating angular, parallel and combined misalignments.

The special configuration with the single-piece sleeve and the seals at the two ends renders the couplings suitable for use in aggressive environments and in particularly demanding operating conditions. The performance complies with the characteristics of a dual articulation, constant-velocity coupling intended to be used both for general and specific applications and with the possibility of also being mounted on shafts with a large free gap.

The operating limits defined by the maximum torque, by the rotating speed and the permitted angular misalignment are the result of a design based on a targeted choice of materials, the heat treatment and the toothing geometry.

The reliability of the stated operating limits has been confirmed by testing the fatigue limits both at the surface pressure (Hertzian pressure) and at bending and to destructive wear in accordance with calculation schemes based on the most authoritative international standards.

The CHIARAVALLI Trasmissioni Technical Department is available however, to examine problems that relate to the choice, application and maintenance of couplings in collaboration with users.

**On specific request,
special couplings by**

their shape, execution and performance can be offered and produced, as an alternative to the normal execution couplings. For example:

- Couplings designed for high angular and parallel misalignments.
- Couplings manufactured using high resistance steel and with surface hardening heat treatment.
- Couplings with case hardened and hardened hubs and tothing finished by machine tools after heat treatment (skiving using a hard metal tool).
- Special couplings manufactured to a drawing.

STRUCTURAL CHARACTERISTICS

The **GFA** range of compact couplings, comprise two toothed hubs and an external connecting single-piece sleeve.

The lubricant seal inside the coupling is ensured by two ring gaskets, arranged at the two ends of the sleeve and held in position by spring washers (Seeger washers).

Two threaded dowels arranged radially on the sleeve in a counter-position allow a solid lubricant to be adopted.

The tothing adopted for the two hubs is profile corrected and has a progressive dual curvature achieved by machine the tothing on a fully Numerically Controlled gear cutting machine.

The sleeve's profile corrected tothing, which has a parallel generatrix, is obtained using a shaping tool.

The tothing is produced to category 7 precision, in compliance with DIN 3972 and has a degree of finish with a surface roughness of not more than $Ra = 1.4$ micrometres, thanks to the machining technology adopted.

Both the hubs and the sleeve are manufactured using hardened and tempered carbon steel with a tensile stress resistance of 800 N/mm. The couplings are subjected to a surface hardening thermo-chemical treatment at the end of the machining stage, which ensures a high resistance to wear and seizure and also confers a high resistance to corrosion caused by atmospheric agents.

The perfect seal achieved by the gaskets ensures the required lubricant containment and prevents penetration of contaminating elements from outside, thereby contributing to increase the average useful working life of the coupling, even if operating in an aggressive environment.

The two toothed hub bands are positioned at the maximum distance permitted by the sleeve length. This arrangement ensures a minimum angular misalignment for a given parallel misalignment and enhances the coupling's constant-velocity features.

" GIFLEX[®] " GFA FLEXIBLE COUPLINGS

Code interpretation

Example:

GFA - 25-NN = with 2 normal hubs

GFA - 25-NL = with one normal hub and a long hub

GFA - 25-LL = with 2 long hubs

DIMENSIONS

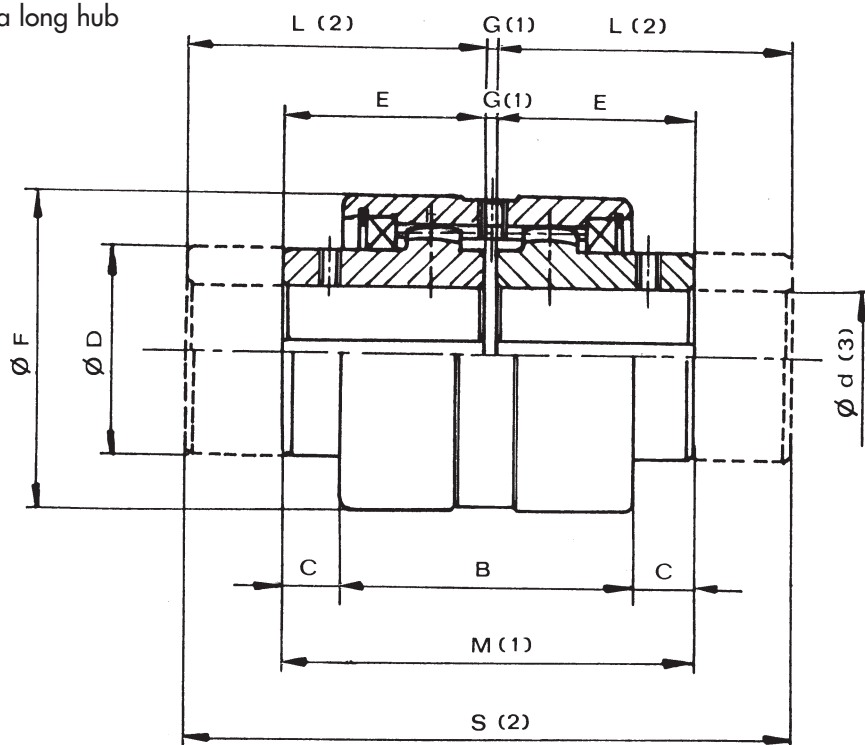

The coupling's characteristic size is defined by the maximum bore diameter.

MISURE - PESO

COUPLING TYPE	BORE	Finished bore d ⁽³⁾		Measurements in mm.									Mass Kg		
		nom.	max.	Normal range					Long Range				Sleeve	Normal Hub	Long Hub
				B	C	ØD	E	ØF	G ⁽¹⁾	M ⁽¹⁾	L ⁽²⁾	S ⁽²⁾			
GFA-25	-	25	28	61	12	42	41	68	3	85	60	123	0.72	0.48	0.69
GFA-32	-	32	38	73	13.5	55	48.5	85	3	100	80	163	1.14	0.99	1.58
GFA-40	-	40	48	82	16.5	64	56	95	3	115	80	163	1.68	1.49	2.10
GFA-56	-	56	60	97	21.5	80	68	120	4	140	100	204	2.86	2.96	4.22
GFA-63	-	63	70	108	22.5	100	74.5	140	4	153	119.5	243	3.75	4.90	7.67
GFA-80	-	80	90	125	22.5	125	82.5	175	5	170	140	285	5.58	8.72	14.26
GFA-100	-	100	110	148	34	150	105	198	6	216	174.5	355	6.63	15.76	25.40
(4) GFA-125	40	125	140	214	39	190	140	245	8	288	207.5	423	17.70	32.60	49.50
(4) GFA-155	40	155	175	240	64	240	180	300	10	370	245	498	28.30	65.50	91.40

(1) Assembly distances.

(2) Couplings with hub lengths to fully cover normal shafts for the UNEL-MEC range of motors.

(3) **On request:** finished bore in compliance with ISO standards, H7 tolerance, keyway DIN 6885, sheet 1, JS9 tolerance. Dowel bore.

(4) Construction material: hardened and tempered 39NiCrMo3.

"GIFLEX®" GFAS FLEXIBLE COUPLINGS

Code interpretation

Example:

GFAS - 25-NN = with cone and a normal hub

GFAS - 25-NL = with cone and a long hub

GFAS - 25-LN = with long cone and normal hub

GFAS - 25-LL = with long cone and long hub

DIMENSIONS

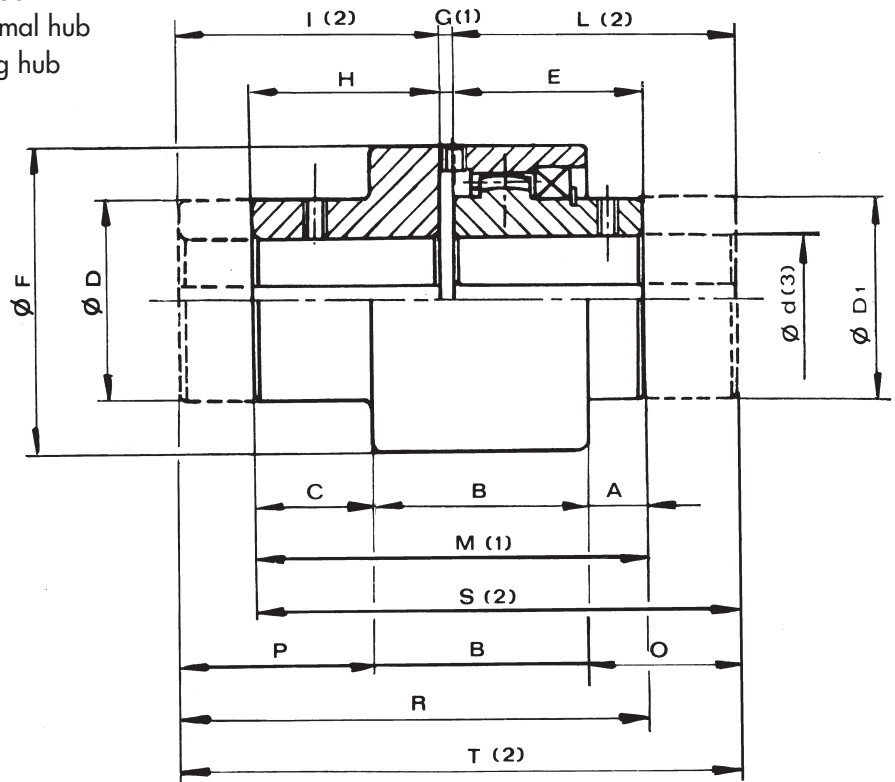

The coupling's characteristic size is defined by the maximum bore diameter.

MEASUREMENTS - WEIGHTS

COUPLING TYPE	WITHOUT BORE	Finished bore d ⁽³⁾		Measurements in mm.																	Mass Kg.			
				Normal range								Long Range ⁽²⁾									Normal cone	Normal Hub	Long Cone	Long Hub
				nom.	max.	A	B	C	ØD	ØD1	E	ØF	G ⁽¹⁾	H	M ⁽¹⁾	I ⁽²⁾	L ⁽²⁾	O	P	R				
GFAS-25	-	25	28	13	43	29	42	40	41	70	3	41	85	60	60	32	48	104	104	123	1.03	0.48	1.30	0.69
GFAS-32	-	32	38	16	49	35	55	55	48.5	85	3	48.5	100	80	80	47.5	66.5	131.5	131.5	163	1.75	0.99	2.50	1.58
GFAS-40	-	40	48	18.5	54.5	42	64	64	56	95	3	56	115	80	80	42.5	66	139	139	163	2.71	1.49	3.40	2.10
GFAS-56	-	56	60	27	60	45	80	80	68	120	4	60	132	100	100	59	85	172	164	204	4.43	2.96	6.10	4.22
GFAS-63	-	63	75	31	63	46	100	100	74.5	140	4	61.5	140	119.5	119.5	76	104	198	185	243	6.62	4.90	10.20	7.67
GFAS-80	-	80	90	26	76	51	125	125	82.5	175	5	65.5	153	138	140	83.5	123.5	225.5	210.5	283	10.50	8.68	17.90	14.22
GFAS-100	-	100	110	38	92	71	150	150	105	198	6	90	201	162	174.5	107.5	143	273	270.5	342.5	28.20	15.70	38.10	25.30

(1) Assembly distances.

(2) Couplings with hub lengths to fully cover normal shafts for the UNEL-MEC range of motors.

(3) **On request:** finished bore in compliance with ISO standards, H7 tolerance, keyway DIN 6885, sheet 1, JS9 tolerance. Dowel bore.

COUPLING SELECTION AND SIZING CRITERIA

The satisfactory operation and the useful working life of flexible toothed couplings depends on the correct selection of the couplings, as well as on the compatibility of the operating conditions with the performance provided by the coupling.

It is essential therefore, to highlight the limiting performance of the couplings and to clarify the actions of the external loads that are exerted on the corresponding couplings.

The basic design ensures that all the couplings are capable of compensating a static angular or assembly misalignment equal to 1 degree and this is ensured by the minimum construction tolerance between the teeth.

The dynamic angular or operating misalignment must never be greater than 0.5 degrees, even if the recommended values should not be greater than 0.25 degrees.

The declared nominal torque values and the maximum rotating speeds indicated refer to an angular or composite misalignment that does not exceed 1/12 of a degree (5 prime divisions).

The 'exceptional' torque values that can be supported as a transient and during the acceleration phases must not be exerted for more than 10-15 seconds and must not occur for more than 5 events/hour.

Fatigue durations are calculated for a conventional limit of 50 million cycles, considering two load cycles for each revolution of the coupling.

Misalignments exceeding 1/8 degrees (7.5 prime divisions) penalise by decreasing the nominal torque and the maximum rotating speed declared for the individual couplings.

The performance of the coupling in terms of torque, limiting speed and useful working life will decrease or increase compared with the declared values in the case of operating conditions that differ from the conditions specified above or for "fixed-term" durations.

The design data has been tested for the purpose of ensuring a reasonable safety margin. The declared performance therefore, is to be understood as valid for a Service Factor equal to 1.

Use of the prescribed lubricants and compliance with the recommended restore time intervals represent the pre-conditions to achieve the performance as described in the catalogue.

The CHIARAVALLI Trasmissioni Technical Department is available to advise users in selecting the type of coupling most appropriate for the actual operating conditions and to make recommendations in relation to special operating conditions.

TECHNICAL DATA

COUPLING TYPE	POWER FACTOR KW r.p.m.		TORQUE Nm		POWER TRANSMITTED IN KW AT R.P.M.				Max. R.P.M.	R.P.M. Recommended limit	Max. radial misalignment mm.	Mass Kg.	J Kg cm ²
	norm.	except.	norm.	except.	750 norm.	1000 norm.	1500 norm.	3000 norm.					
GFA-25	0.061	0.157	600	1524	45	61	91	183	6000	5000	0.20	1.36	8.68
GFAS-25											-	1.35	7.31
GFA-32	0.103	0.259	1000	2520	77	103	154	309	5000	4000	0.26	2.51	25.10
GFAS-32											-	2.43	19.15
GFA-40	0.128	0.322	1250	3125	96	128	192	384	4200	3000	0.32	3.55	44.82
GFAS-40											-	3.64	34.13
GFA-56	0.257	0.639	2500	6200	192	257	385		3500	2200	0.37	6.15	132.60
GFAS-56											-	6.07	96.56
GFA-63	0.412	0.985	4000	9260	309	412	618		3000	1600	0.40	9.91	278.20
GFAS-63											-	10.00	207.32
GFA-80	0.773	1.855	7500	18000	579	773			2600	1200	0.48	16.20	558.6
GFAS-80											-	19.18	492.6
GFA-100	1.236	2.937	12000	28500	927				1400	700	0.65	23.00	1044.50
GFAS-100											-	28.00	1064.00
GFA-125	2.431	5.795	23600	56250	1823				950	460	0.70	49.15	3650
GFA-155	4.121	9.273	40000	90000	3090				700	350	0.80	91.30	9982

(1) Referred to the normal coupling complete with maximum bore without keyway.

N.B. Class G 2.5 dynamic balancing in compliance with ISO 1940 is recommended for actual operating speeds that exceed 3,600 r.p.m.

Couplings can operate with a parallel misalignment value that is double the suggested value and assembly with a misalignment value that is four times greater than the suggested value in exceptional cases.

COUPLING SIZE SELECTION INSTRUCTIONS

The torque, speed and useful working life data declared for the couplings are to be understood as valid referred to a Service Factor SF = 1.

The service factor must be determined therefore, based on the type of load, the load intensity and the range factor that characterises the type of load exerted on the coupling.

The values shown in the following table can be considered as a precautionary measure in the absence of reliable service factor design data.

It is appropriate to multiply the service factor taken from the table by an increasing factor equal to 1.4 in the case of continuously reversible operations under load.

LOAD CONDITION

SERVICE FACTORS

UNIFORM
LIGHT
MEDIUM
HEAVY

OPERATING CONDITIONS

Regular operation without impacts or overloads
 Regular operation with minor and infrequent impacts and overloads
 Irregular operation with medium overloads for a short duration and frequent but moderate impacts
 Markedly irregular operation with very frequent impacts and overloads and of major intensity.

TYPE OF DRIVE

Electric motor	Diesel engine
1.25	1.5
1.50	2.0
2.0	2.5
2.5	3.0

TEST BASED ON THE POWER TO BE TRANSMITTED

Use the following formula to calculate the value of the operating torque (M_e) expressed in Nm, considering the drive motor power output (P) in kW and the operating speed (n) in r.p.m.

$$M_e = \frac{9549 \times P}{n}$$

Establish the nominal torque to be transmitted (M_n) based on the service factor taken from the table.

$$M_n = M_e \times S_f$$

Select the coupling with a nominal torque which is GREATER than the value calculated.

WARNING

The declared nominal torques must be progressively decreased for angular misalignments that exceed 0.125 degrees.

TEST BASED ON THE SHAFT DIAMETER

Check that the largest of the shafts to be connected has a diameter equal to or less than the nominal bore declared for the coupling.

Adopting the maximum permitted diameter for the selected coupling should be limited to UNIFORM or LIGHT load conditions.

TEST BASED ON THE ROTATING SPEED

The maximum rotating speed indicated for each coupling represents an operating limit calculated for an angular misalignment that does not exceed 1/12 of a degree. Both the nominal torque and the permitted rotating speed are reduced for greater angular misalignments. Adopt a coefficient equal to 1.12 to increase the service factor and select the coupling as described previously when both the misalignment and the operating speed are less than the suggested reference values, but are close to these values. Contact our Technical Services for operating conditions with misalignments and operating speeds that exceed the suggested reference values.

TEST BASED ON THE REQUIRED USEFUL WORKING LIFE

Couplings are calculated for a standard operating lifespan under nominal operating conditions (torque, misalignment and rotating speed). Operating lifespans that exceed the standard duration cause the nominal torque to decrease.

The service factor must be multiplied by a lifespan coefficient defined as follows if a given operating lifespan, which exceeds the standard working lifespan, is required.

OPERATING LIFESPAN IN HOURS	3.800	4.000	6.000	8.000	12.000	20.000
LIFESPAN COEFFICIENT	1	1.06	1.17	1.26	1.39	1.58

The nominal torque verified for the lifespan must be further decreased in the fairly improbable circumstance in which the actual operating speed is greater than the maximum permitted operating speed for the misalignment conditions of the coupling when in operation.

COMPONENT PARTS OF THE "GIFLEX®" GFA COUPLING

COUPLING TYPE	POS. 1		POS. 2		POS. 3		POS. 4		POS. 5			
	Description	No. of pieces	Description	No. of pieces	Seal ring Corteco NBR DIN 3760 A	No. of pieces	Flexible ring for bores DIN 472	No. of pieces	Flat dowel UNI 5923	No. of pieces	Allen wrench	No. of pieces
GFA-25	Sleeve	1	Hub	2	BA 42x56x7	2	56 I	2	M6x8	2	D.3	1
GFA-32	Sleeve	1	Hub	2	BA 55x72x8	2	72 I	2	M6x8	2	D.3	1
GFA-40	Sleeve	1	Hub	2	BA 64x80x8	2	80 I	2	M6x8	2	D.3	1
GFA-56	Sleeve	1	Hub	2	BA 80X100X10	2	100 I	2	M6x8	2	D.3	1
GFA-63	Sleeve	1	Hub	2	BA 100x125x12	2	125 I	2	M6x8	2	D.3	1
GFA-80	Sleeve	1	Hub	2	BA 125x160x12	2	160 I	2	M6x8	2	D.3	1
GFA-100	Sleeve	1	Hub	2	SMIM 150x180x12	2	180 I	2	M6x8	2	D.3	1
GFA-125	Sleeve	1	Hub	2	SM 190x220x15	2	220 I	2	M6x8	2	D.3	1
GFA-155	Sleeve	1	Hub	2	SMIM 240X280X15	2	280 I	2	M6x8	2	D.3	1

COMPONENT PARTS OF THE "GIFLEX®" GFA COUPLING

COUPLING TYPE	POS. 1		POS. 2		POS. 3		POS. 4		POS. 5			
	Description	No. of pieces	Description	No. of pieces	Seal ring Corteco NBR	No. of pieces	Flexible ring for bores DIN 471	No. of pieces	Flat dowel UNI 5923	No. of pieces	Allen wrench	No. of pieces
GFAS-25	Sleeve	1	Hub	1	UM 60X40X10	1	40 E	1	M6x8	2	D.3	1
GFAS-32	Sleeve	1	Hub	1	UM 75x55x10	1	55 E	1	M6x8	2	D.3	1
GFAS-40	Sleeve	1	Hub	1	UM 85x65x10	1	65 E	1	M6x8	2	D.3	1
GFAS-56	Sleeve	1	Hub	1	UM 100x80x10	1	80 E	1	M6x8	2	D.3	1
GFAS-63	Sleeve	1	Hub	1	UM 120x100x10	1	100 E	1	M6x8	2	D.3	1
GFAS-80	Sleeve	1	Hub	1	UM 155x125x15	1	125 E	1	M6x8	2	D.3	1
GFAS-100	Sleeve	1	Hub	1	UM 180x150x15	1	150 E	1	M6x8	2	D.3	1

ASSEMBLY INSTRUCTIONS

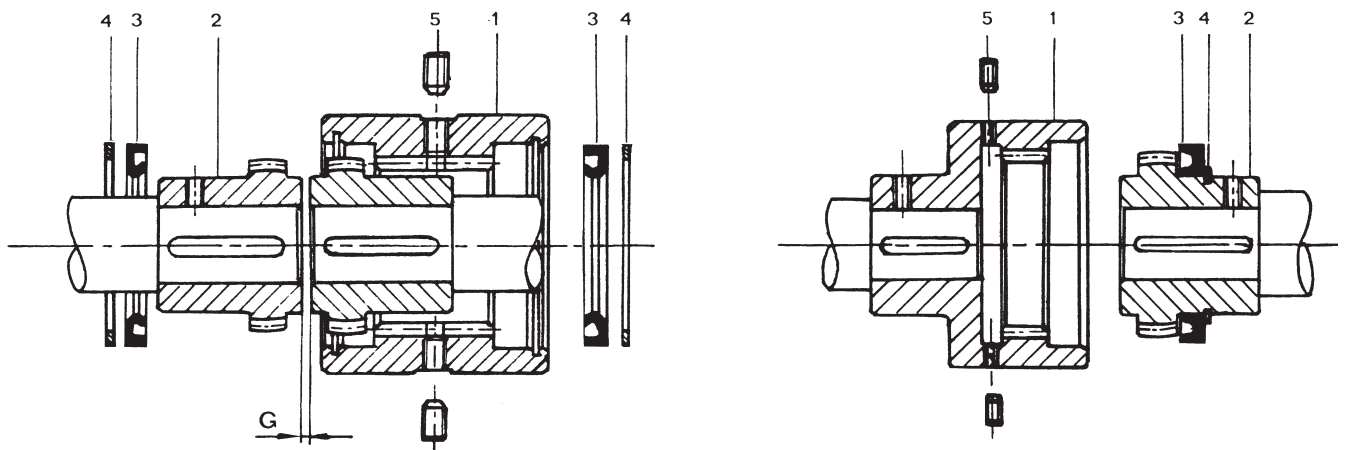

— GFA ASSEMBLY

- A) Insert the stop ring (4) and the seal ring (2) on the shaft.
- B) Assemble the hubs (2) on the relative shafts.
- C) Sleeve (1) is to be fitted on the longest shaft.
- D) Position the shafts close together and check that the distance G corresponds to the value indicated in the table.
- E) Align the shafts and check the parallelism then tighten the hubs on the shaft.
- F) Fill the tothing and the gap between the hubs with grease.
- G) At this stage slide the sleeve (1) down and position the sealing rings (3) in its place and tighten the stop rings (4) in their seat.
- H) Proceed as follows for disassembly: remove the stop rings (4) using a pair of pliers, separate the sleeve (1) from the hubs (2) and the GFA coupling is fully disassembled.

MAINTENANCE

Unscrew both plugs (5) then introduce grease using the grease gun through the greasing holes until the grease exits from the other hole positioned at 180°. Replace the plugs. Repeat this operation every 1.000 working hours.

— GFAS ASSEMBLY

- A) The seal ring (3) and stop ring (4) are already fitted on the extractable hub (2).
- B) Assembly in closed cone mode only requires the sleeve (1) to be fixed onto one shaft and the extractable hub (2) to be tightened on the other shaft.
- C) Then arrange the shafts to be connected closely together, positioning the hub (2) over the sleeve (1).
- D) To disassemble, separate the shafts then extract the hub (2) from the sleeve (1).

Couplings require lubrication with grease, the quantity of grease used should half fill the available gap.

Use of Lithium soap grease with a base mineral oil and consistency index 2 (in compliance with NLGI) is recommended for moderate loads and normal operating conditions.

Use Barium complex soap grease, PAO synthetic base oil and consistency index 2 for heavy-duty operating conditions as regards temperatures and with heavy loads.

Contact the CHIARAVALLI Trasmissioni spa Technical Department for extreme operating conditions.

The lubricant complying with the formulation and with the recommended characteristics can be selected from among the range of products indicated below by consulting the Producer.

Equivalent recommended greases are as follows:

TYPE	PRODUCER
Sovarex L-O	MOBIL OIL
Gulfrown EP-O	GULF OIL
Alesia EP-2	SHELL OIL
Litholine Multi-Purpose	SINCLAIR
PGX-2 API	
Mariax 1	TEXACO
GR MUIEP2	AGIP
SPHEEROL EPL 2 SUPERGREASE 2	CASTROL

N.B. - The technical characteristics, the dimensions and all other data contained in this catalogue are not binding. CHIARAVALLI Trasmissioni spa reserves the right to change the measurements indicated at any time and without notice.

FRICTION TORQUE LIMITERS

The torque limiter is adopted where there is a need to provide efficient protection against overloads on mechanical parts (kinematic motions or machines). The easy-to-use and efficient device ensures complete operating reliability, the torque limiter device slips when the torque required exceeds the pre-set value and automatically restores the operating mode when the overload condition no longer applies.

The component selected from the pulleys, chain sprockets and gears is positioned between the friction discs, which develop a friction force generated by tightening the ring nut, anchored by compressing the cup springs.

Torque limiter selection:

T_{kw} = Power output expressed in kW n = r.p.m.

M_t = Twisting moment (Nm)

The twisting moment is given by the following relationship:

$$M_t = \frac{9550 \cdot T_{kw}}{n}$$

Example: Assuming a motor with the following characteristics is operated:

Power output 4 kW and $n = 1.550$ r.p.m.

$$M_t = \frac{9550 \cdot 4}{1550} = 24.64 \text{ Nm.}$$

We will therefore select a limiter with a torque value equal to or greater than 24.64 Nm.

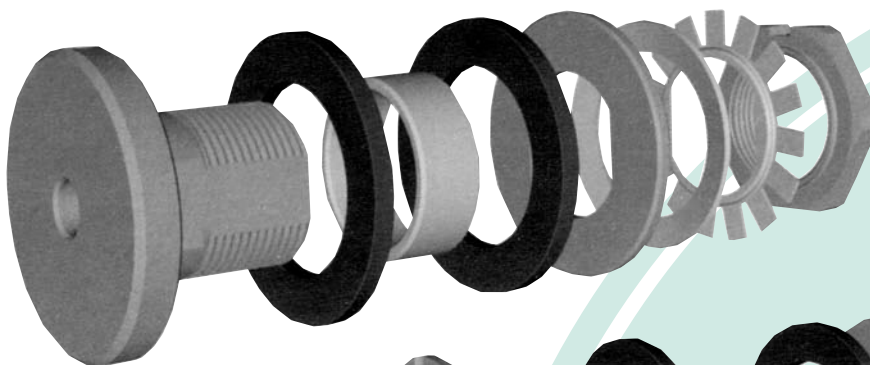

LC 40-45-65-85

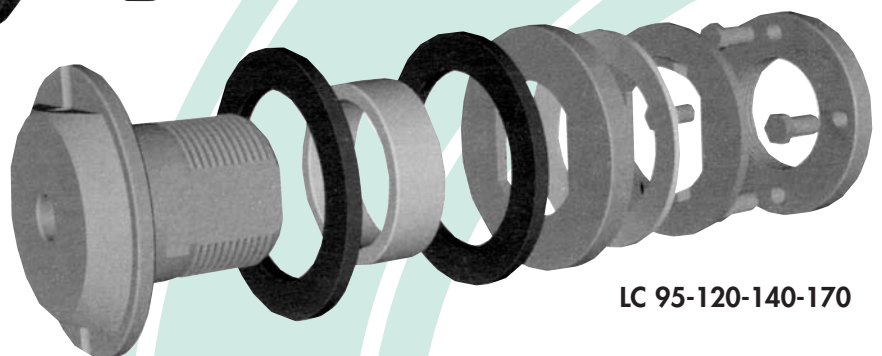

LC 95-120-140-170

FR ICTION TORQUE LIMITERS

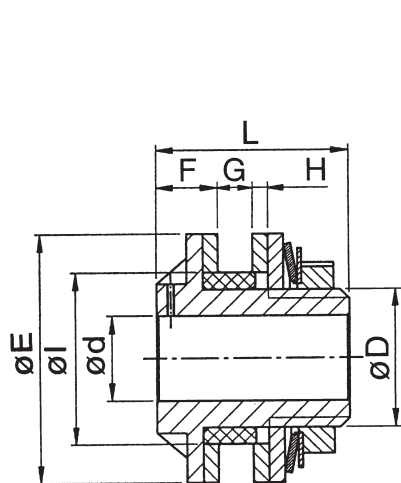

LC 40 - 45 - 65 - 85

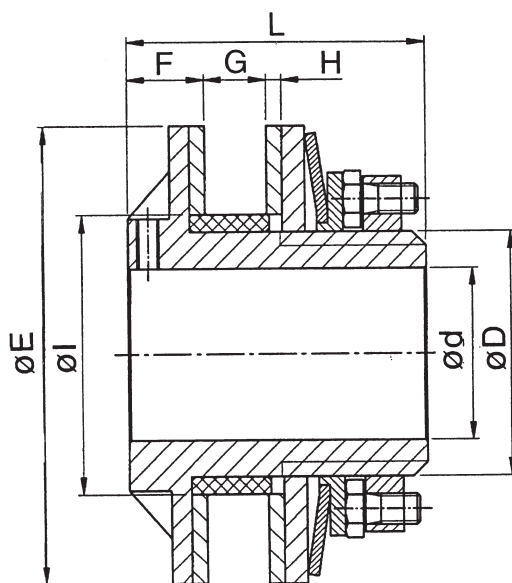

LC 95 - 120 - 140 - 170

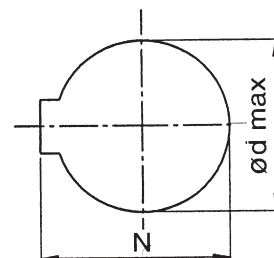

EXAMPLE:

LC 85-1 with 1 spring

LC 85-2 with 2 springs

TECHNICAL DATA

TYPE	ØE	ØIh8	Ød	F	G max	H	ØD	L	Max bore - key DIN 6885/1		Torque Max N/m	No. of springs	Gears for standard chain	
									on request Ø d max	N			Pitch for roller Ø	No. of teeth
LC 40-1 LC 40-2	40	26	7	10	6	3	22	30	14	16.3	15 28	1 2	3/8" x 6.35 1/2" x 8.51	18-21 15
LC 45-1 LC 45-2	45	35	7	11	6	3	32	35.5	20	22.8	30 55	1 2	3/8" x 6.35 1/2" x 8.51	19-23 17
LC 65-1 LC 65-2	65	45	10	16	9	4	36	50.5	22	24.8	70 120	1 2	3/8" x 6.35 1/2" x 8.51 5/8" x 10.16	27 21 19
LC 85-1 LC 85-2	85	52	15	17	11	4	42	55.5	25	28.3	130 240	1 2	3/8" x 6.35 1/2" x 8.51 5/8" x 10.16 3/4 x 12.07	38 25 21 18
LC 95-1 LC 95-2	95	60	15	18	11	4	52	67	35	38.3	190 340	1 2	1/2" x 8.51 5/8" x 10.16 3/4 x 12.07	30 25 19
LC 120-1 LC 120-2	120	73	20	20	16	4	64	78	45	48.8	350 650	1 2	1/2" x 8.51 5/8" x 10.16 3/4 x 12.07 1" x 15.88	38 32 25 21
LC 140-1 LC 140-2	140	90	20	23	17	4	85	86.5	60	64.4	650 1200	1 2	3/4 x 12.07 1" x 15.88	35 21
LC 170-1 LC 170-2	170	100	28	27.5	18.5	4.5	90	95	65	69.4	1000 1800	1 2	3/4 x 12.07 1" x 15.88 1" 1/4 x 19.05	35 25 22

N.B. We strongly recommend the LC range of limiters to be used dry, checking very carefully that greasy product or liquids in general do not come into contact with the friction materials to avoid a sudden and inevitable deterioration in performance. The driving bush is to be adjusted according to own requirements. **Friction discs are absolutely asbestos-free.**

HEAVY GAUGE TURNED WASHERS

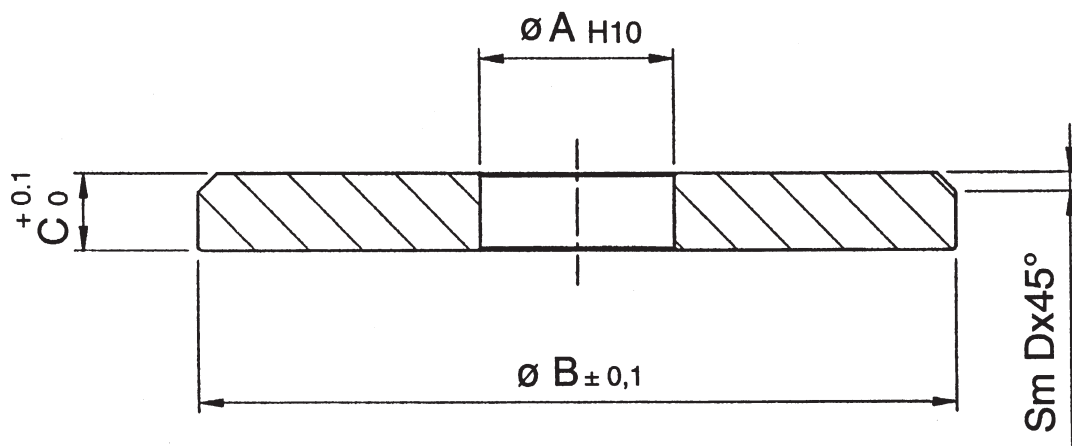

MATERIAL: C 45 – UNI 7845 – PHOSPHATED - GALVANISED

TYPE	A	B	C	D
C-RGS 3-10	3.2	10	2	0.5
C-RGS 4-10	4.2	10	2	0.5
C-RGS 4-15	4.2	15	3	0.5
C-RGS 5-15	5.2	15	3	0.5
C-RGS 5-20	5.2	20	3	0.5
C-RGS 5-25	5.2	25	4	1
C-RGS 5-30	5.2	30	4	1
C-RGS 6-15	6.2	15	3	0.5
C-RGS 6-20	6.2	20	3	0.5
C-RGS 6-25	6.2	25	4	1
C-RGS 6-30	6.2	30	4	1
C-RGS 6-35	6.2	35	5	1
C-RGS 6-40	6.5	40	5	1
C-RGS 8-20	8.5	20	4	0.5
C-RGS 8-25	8.5	25	4	1
C-RGS 8-30	8.5	30	4	1
C-RGS 8-35	8.5	35	5	1
C-RGS 8-40	8.5	40	5	1
C-RGS 8-45	8.5	45	5	2
C-RGS 8-50	8.5	50	6	2
C-RGS 10-25	10.5	25	4	1
C-RGS 10-35	10.5	35	5	1
C-RGS 10-40	10.5	40	5	1
C-RGS 10-45	10.5	45	5	2
C-RGS 10-50	10.5	50	6	2
C-RGS 12-50	12.5	50	6	2

Packages containing 50 pieces.

COLLARS IN COMPLIANCE WITH DIN 705

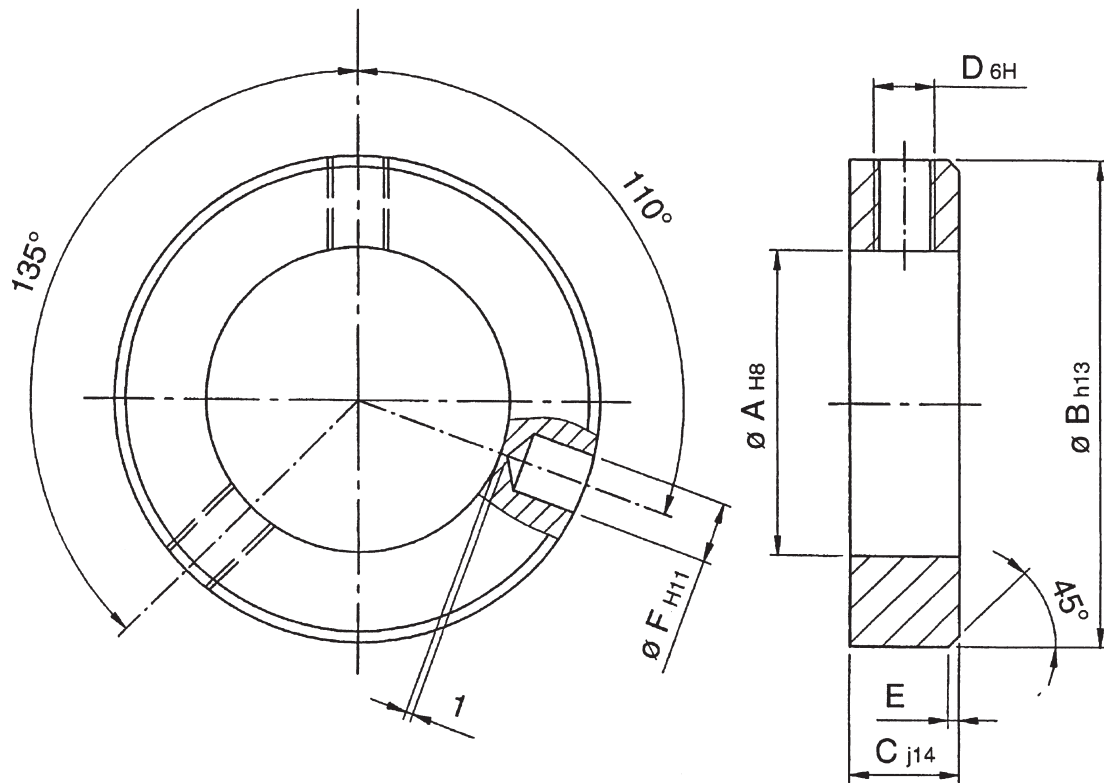

* Also available in INOX AISI 304

MATERIAL: C 45 – UNI 7845 – PHOSPHATED - GALVANISED

TYPE	A	B	C	D	E	F
C-ABU 6 *	6	12	8	M4	0.8	1.5
C-ABU 8 *	8	16	8	M4	0.8	2
C-ABU 10 *	10	20	10	M5	1	3
C-ABU 12 *	12	22	12	M6	1.2	4
C-ABU 14	14	25	12	M6	1.2	4
C-ABU 15 *	15	25	12	M6	1.2	4
C-ABU 16 *	16	28	12	M6	1.2	4
C-ABU 17 *	17	28	12	M6	1.2	4
C-ABU 18	18	32	14	M6	1.4	5
C-ABU 20 *	20	32	14	M6	1.4	5
C-ABU 25 *	25	40	16	M8	1.6	6
C-ABU 30 *	30	45	16	M8	1.6	6
C-ABU 35 *	35	56	16	M8	1.6	8
C-ABU 40 *	40	63	18	M10	1.8	8
C-ABU 45	45	70	18	M10	1.8	8
C-ABU 50 *	50	80	18	M10	1.8	10
C-ABU 60	60	90	20	M10	2	10
C-ABU 70	70	100	20	M10	2	10

Packages containing 100 pieces C-ABU 6÷20 - Packages containing 50 pieces C-ABU 25÷70

C - A B C O L L A R S

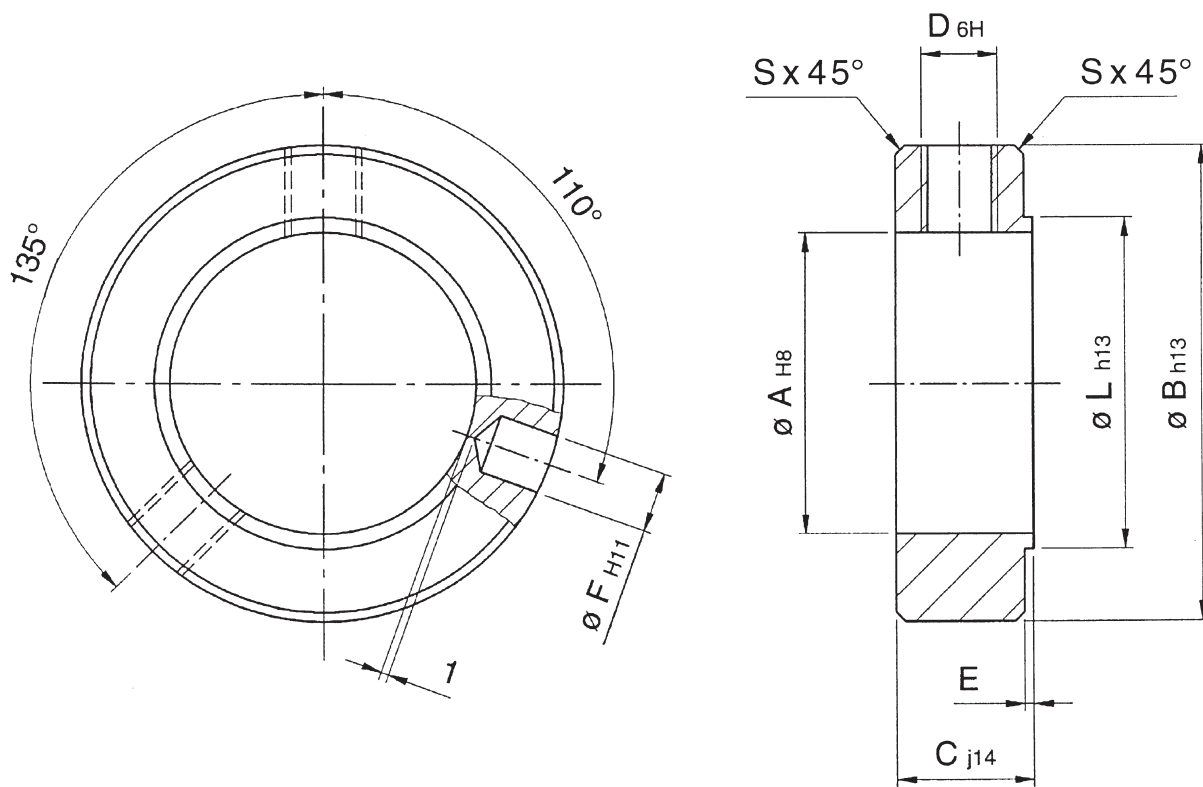

MATERIAL: C 45 - UNI 7845 - PHOSPHATED - GALVANISED

TYPE	A	B	C	D	E	F	L	S
C-AB 6	6	12	8	M4	0.6	1.5	8	0.3
C-AB 8	8	16	8	M4	0.8	2	10	0.3
C-AB 10	10	20	10	M5	0.8	3	13	0.3
C-AB 12	12	22	12	M5	0.8	4	15	0.5
C-AB 15	15	25	12	M6	1	4	18	0.6
C-AB 17	17	28	12	M6	1	4	20	0.6
C-AB 20	20	32	14	M6	1	5	24	0.8
C-AB 25	25	40	16	M6	1	6	29	0.8
C-AB 30	30	45	16	M8	1.2	6	34	1
C-AB 35	35	56	16	M8	1.2	8	39	1
C-AB 40	40	63	18	M10	1.2	8	44	1

Packages containing 100 pieces C-AB 6÷20 - Packages containing 50 pieces C-AB 25÷40

C L A M P I N G C O L L A R S

MATERIAL: C 45 – UNI 7845 – PHOSPHATED - GALVANISED

TYPE	Ø A	Ø B	C	D	Ø E	Ø F	G	H	I	Viti
C-ADB 8	8	25	10	15	8	4.5	5	15	1.4	M4x15
C-ADB 10	10	32	10	20	8	4.5	5	15	1.4	M4x15
C-ADB 12	12	32	10	20	8	4.5	5	15	2	M4x15
C-ADB 15	15	40	12	25	10	4.5	7	18	2	M5x20
C-ADB 18	18	45	12	30	10	5.5	7	18	2	M5x20
C-ADB 20	20	45	12	30	10	5.5	7	18	2	M5x20
C-ADB 24	24	50	12	36	10	5.5	7	18	2	M5x20
C-ADB 25	25	50	12	36	10	5.5	7	18	2	M5x20
C-ADB 28	28	56	12	42	10	5.5	7	18	2	M5x20
C-ADB 30	30	56	12	42	10	5.5	7	18	2	M5x20
C-ADB 32	32	56	12	42	10	5.5	7	18	2	M5x20
C-ADB 35	35	63	12	48	10	5.5	7	18	2	M5x20
C-ADB 38	38	63	12	48	10	5.5	7	18	2	M5x20
C-ADB 40	40	70	14	55	11	6.5	7	18	2	M6x20
C-ADB 45	45	80	14	65	11	6.5	7	18	2	M6x20
C-ADB 50	50	80	14	65	11	6.5	7	18	2	M6x20
C-ADB 60	60	100	16	80	14	8.5	7	18	2	M8x20
C-ADB 70	70	110	20	88	17	11	8.5	22	3	M10x25
C-ADB 80	80	125	20	100	17	11	8.5	22	3	M10x25

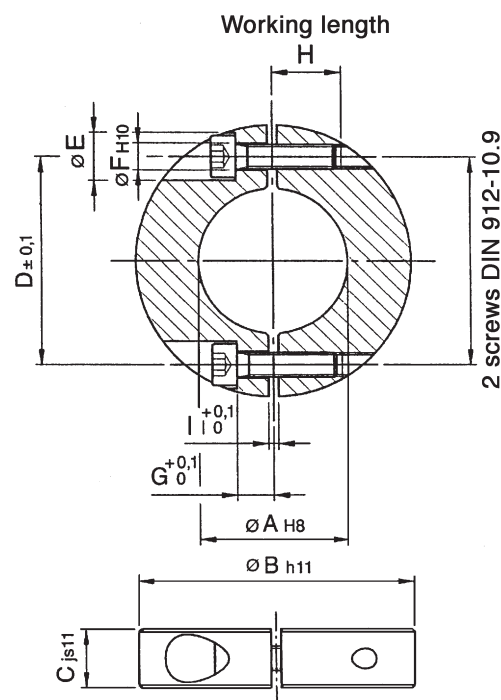

Packages containing 100 pieces C-ADB 8÷40

Packages containing 5 pieces C-ADB 45÷70

T U R N E D T A P E R W A S H E R S

MATERIAL: C 45 – UNI 7845 – PHOSPHATED - GALVANISED

TYPE	Ø A	Ø B	C	Ø D	E	Ø F
C-RC 4	4.1	13	3	8	2.1	8.8
C-RC 5	5.2	16	3.5	10	2.6	10.8
C-RC 6	6.5	18	3.5	12	2.1	13.8
C-RC 8	8.5	25	5	16.5	3.5	18
C-RC 10	10.5	33	7	20.5	6	21
C-RC 12	12.5	40	8	24.5	7	26

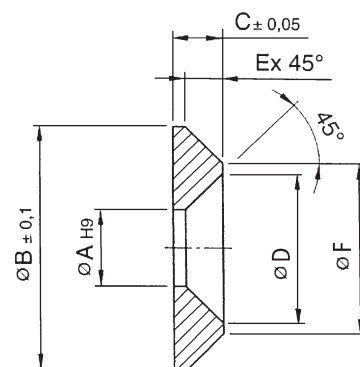

Packages containing 30 pieces

T U R N E D W A S H E R S F O R A R T I C U L A T E D H E A D S

MATERIAL: C 45 – UNI 7845 – PHOSPHATED - GALVANISED

TYPE	Ø A	Ø B	C	Ø D	E	F
C-RS 6	6.5	15	9	1.5	1	4
C-RS 8	8.5	22	12	1.5	2	6.5
C-RS 10	10.5	22	14	1.5	3	6.5

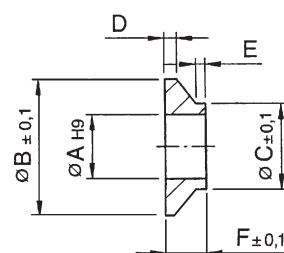

Packages containing 30 pieces

CONDIZIONI GENERALI DI VENDITA

1) ORDERS - Orders for standard and special material shall always be referred to the quotations prepared by CHIARAVALLI Trasmissioni spa. Orders shall be deemed as binding for the Customer. Order cancellations or reductions shall not be accepted after order processing has been started, unless the Customer compensates the material and processing costs sustained up to the time the order is suspended. The quantity dispatched may vary by $\pm 5\%$ compared with the quantity ordered.

2) PRICES - Prices shall be understood as the prices in force at the date the order is placed. All prices refer to goods delivered ex-Premezzo, packing excluded. CHIARAVALLI Trasmissioni spa reserves the right to adjust prices to incorporate increases that have occurred, even for orders in progress, if the price increases for the material or other production costs become applicable during the supply period.

3) DELIVERY TERMS - Only delivery terms indicated by CHIARAVALLI Trasmissioni spa shall be deemed valid. However, delivery terms shall only be considered as indicative. Delivery terms shall be automatically deferred in cases of difficulty in procuring materials, of strikes or however in all circumstances of force majeure without CHIARAVALLI Trasmissioni spa being under an obligation to pay any form of indemnity. In any event the Customer shall be under obligation to collect special material ordered when the material in question becomes available.

4) SHIPMENTS - Shipments shall be understood to be the Customer's responsibility and be made at the Customer's risk, also in the case of shipments made on a carriage free basis. Claims concerning possible shortages shall be submitted within 8 days from the date the goods are received. CHIARAVALLI Trasmissioni spa reserves the right to select the most economic means of dispatch, if it has been agreed that the transport cost, even only in part, shall be borne thereby.

5) PACKING - Packing shall be invoiced at cost.

6) RETURNED GOODS - Returned goods shall not be accepted for any reason, unless previously authorised and with the packing, possible customs clearance operations and return costs being borne fully by the purchaser. A debit note amounting to 15% of the value of the returned goods shall be issued to cover warehousing and administrative costs.

7) WARRANTY - CHIARAVALLI Trasmissioni spa hereby undertakes to repair or replace free of charge parts that the Company acknowledges as faulty. The faulty goods shall be returned to CHIARAVALLI Trasmissioni spa Headquarters, with all costs paid.

The warranty shall be void if the returned parts have been repaired or tampered with. Repairs made by the Customer on faulty pieces shall only be acknowledged if authorised by CHIARAVALLI Trasmissioni spa and following approval of the repair estimate by the latter company.

CHIARAVALLI Trasmissioni spa shall not be held liable or pay indemnities of any kind for damages that occur during use of the Company's products, even if the products are faulty.

8) LIABILITY - CHIARAVALLI Trasmissioni spa shall not be held liable or pay indemnities of any kind for damages that occur during use of the Company's products, even if the products are faulty. CHIARAVALLI Trasmissioni spa declines all liability for the execution of parts made to the Customer's drawing, which may be subject to possible patents.

9) PAYMENTS - Only payments made in the forms and within the terms agreed shall be deemed valid. CHIARAVALLI Trasmissioni spa shall calculate arrears interest at the rate of 3% higher than the legal rate after the payment due date has elapsed, while maintaining the right to demand payment.

CHIARAVALLI Trasmissioni spa reserves the right to suspend deliveries of orders in progress or to demand payment in advance without granting the Customer any form of indemnity or compensation if the Customer delays payment or fails to effect payment.

Any claim concerning the materials in course of production or already delivered to the Customer shall not release the latter party from effecting payment at the agreed due date and for the full invoiced amount without any deduction being made.

10) OWNERSHIP - All goods dispatched shall remain the property of CHIARAVALLI Trasmissioni spa up to the time the relative invoices have been paid in full.

11) JURISDICTION - Any dispute regarding commercial relationships with CHIARAVALLI Trasmissioni spa shall be referred to the jurisdiction of the District of Court of Law of Busto Arsizio (VA).